

The home of the turntable

THE VINYL ENGINE[®]

For more turntable manuals and setup information
please visit www.vinylengine.com

Service Manual

Direct Drive Player System

SL-2000
(XGE,E,E1)



TECHNICAL SPECIFICATIONS (IHF) Specifications are subject to change without notice for further improvement. Weights and dimensions shown are approximate.

Turntable section

Type	Direct Drive Player system
Drive method	Direct Drive
Motor	DC motor employing one chip IC
Turntable platter	Aluminum die-cast, 30.8 cm (12-11/64")
Turntable speeds	33-1/3 and 45 rpm
Pitch controls	Individual adjustment controls, 10% adjustment range
Wow and flutter	0.045% W.R.M.S. (JIS C5521) ±0.065% weighted zero to peak (DIN 45507)
Rumble	-47 dB (DIN 45539A) -70 dB (DIN 45539B)

Tonearm section

Type	Universal tubular arm, static-balanced type
Effective length	220 mm (8-21/32")
Overhang	14 mm (35/64")
Tracking error angle	Within +3° at the point of 145 mm (5-45/64") from the center Within -0.2° at the point of 55mm (2-3/16") from the center

Adjustable stylus pressure range

0 to 3 g (stylus pressure direct reading type)

Cartridge weight range

3 to 8.5 g

Headshell weight

9.5 g

Cartridge section

Type	Moving magnetic stereo cartridge
Frequency response	20 to 25,000 Hz
Output voltage	1.7 to 3.4 mV 1 kHz, 5cm/s. lateral
Channel separation	22 dB at 1 kHz
Channel balance	Within 2 dB at 1 kHz
Load impedance	47 kΩ to 100 kΩ
Stylus pressure	1.75 ± 0.25 g
Replacement stylus	EPS-35STED

General

Power supply	~ 110/120/220/240V, 50 or 60 Hz
Power consumption	5.5 W
Dimensions (H x W x D)	12.5 x 43 x 34.6 cm (4-15/16" x 16-15/16" x 13-5/8")
Weight	6.1 kg (13.4 lbs)

■ PARTS IDENTIFICATION

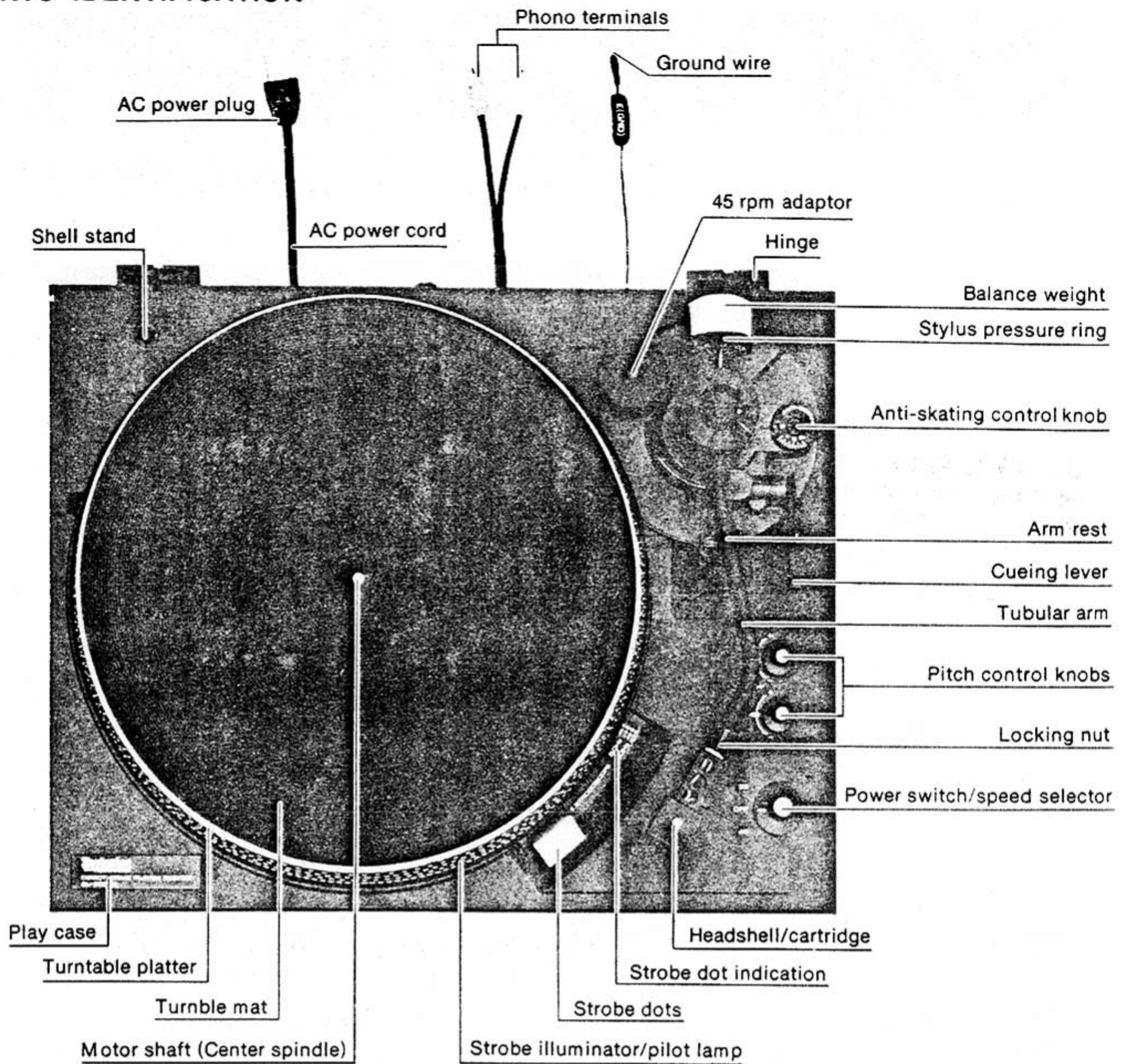

Fig. 1

■ ASSEMBLY AND SET-UP

Horizontally balanced state

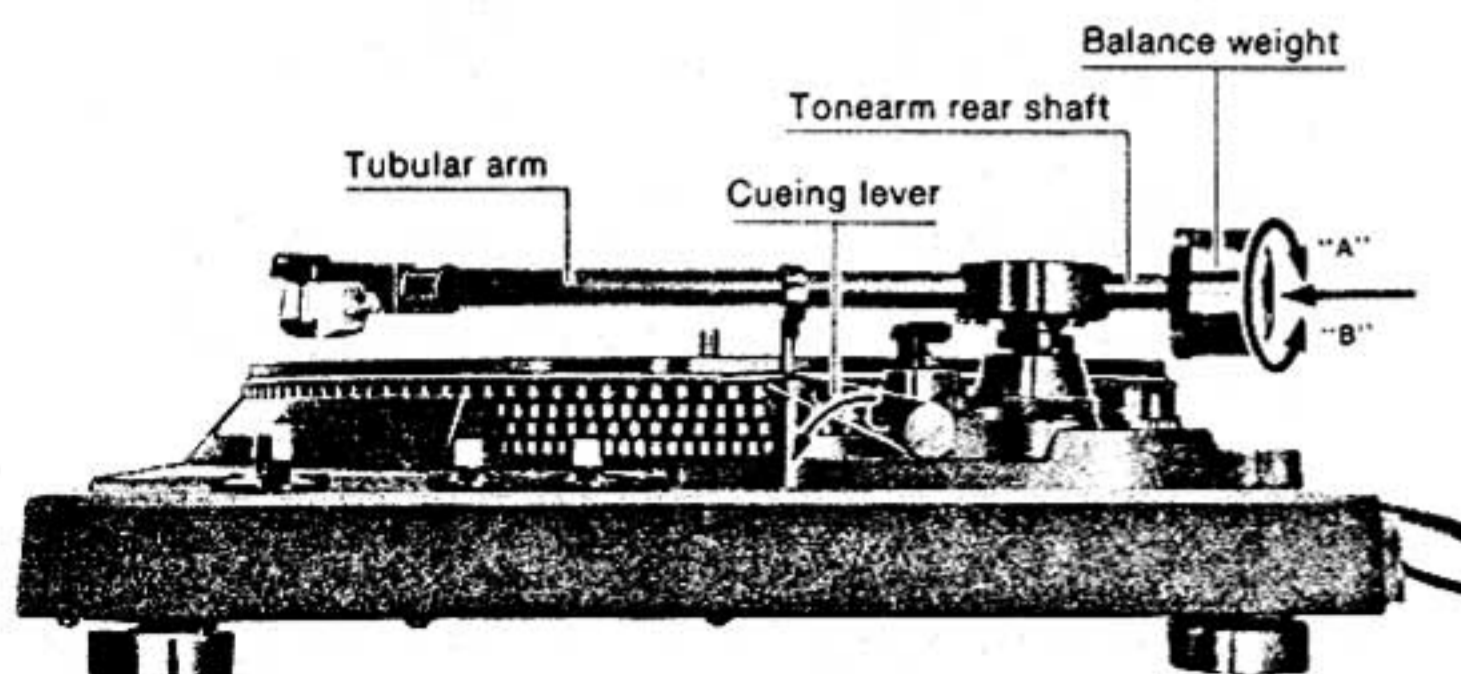

Fig. 2

1. Adjustments of the horizontal "0" balance and the stylus pressure

Before adjusting the horizontal "0" balance, check for the following items.

- 1) Ensure that the cueing lever is in the lowered position as shown in Fig. 2.
- 2) Ensure that the anti-skating knob is at "0" position. (See Fig. 1)
- 3) Make certain that the power switch/speed selector is in "OFF" position. (See Fig. 1)

Mount the balance weight on the tonearm rear shaft. (See Fig. 2)

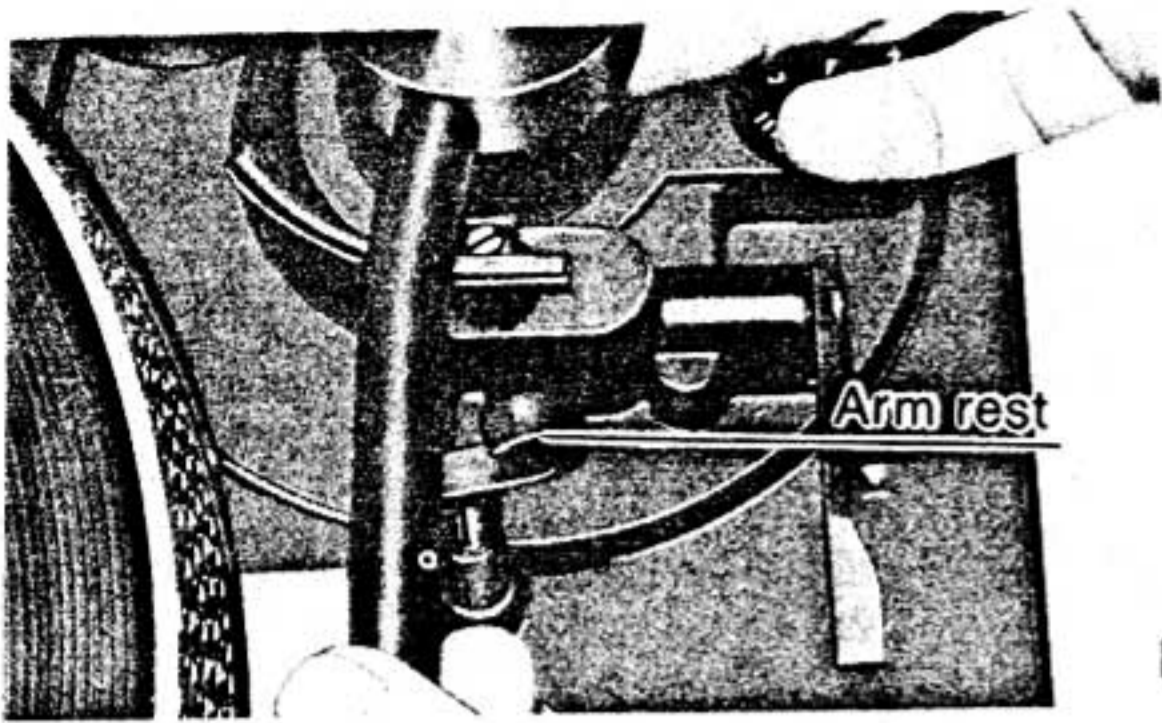

Fig. 3

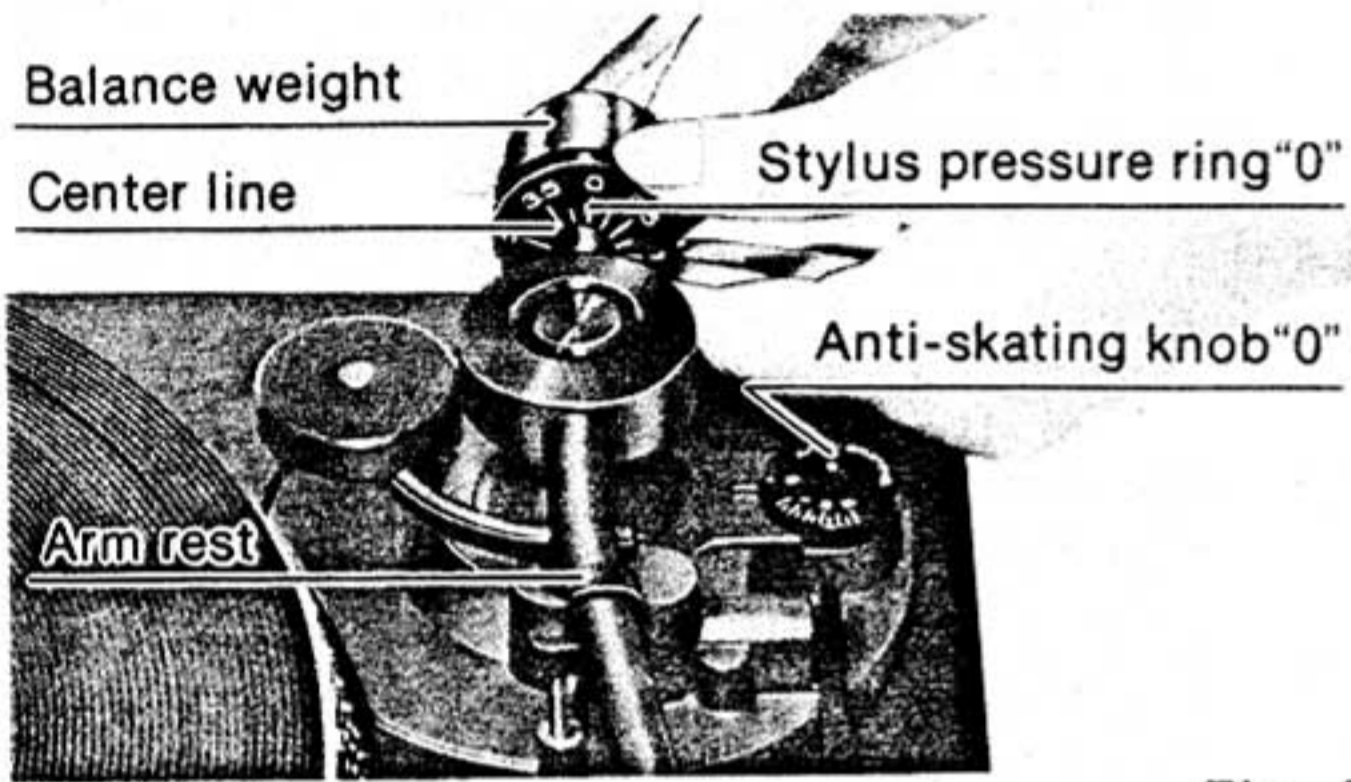

Fig. 4

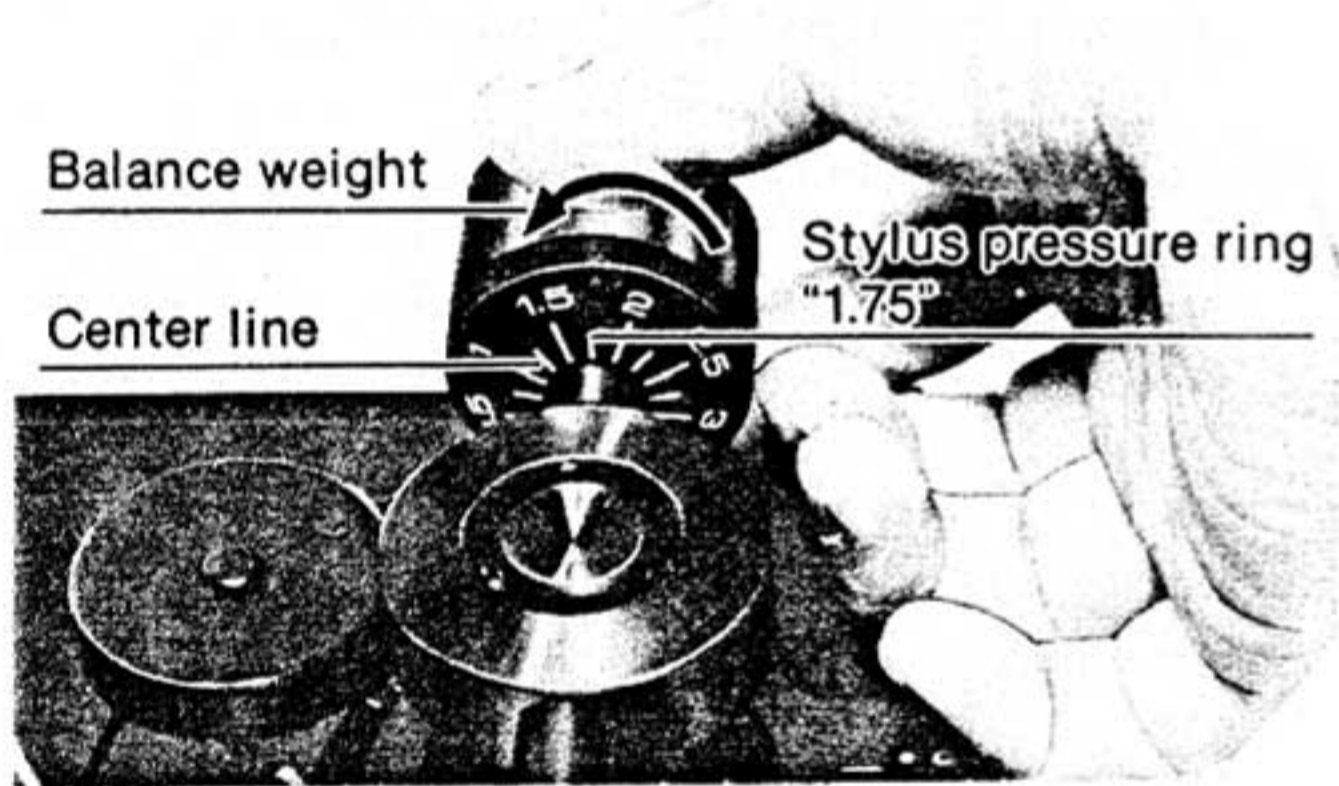

Fig. 5

2. Anti-skating adjustment (Fig. 6)

Set the anti-skating knob to the same value as that of the adjusted stylus pressure.

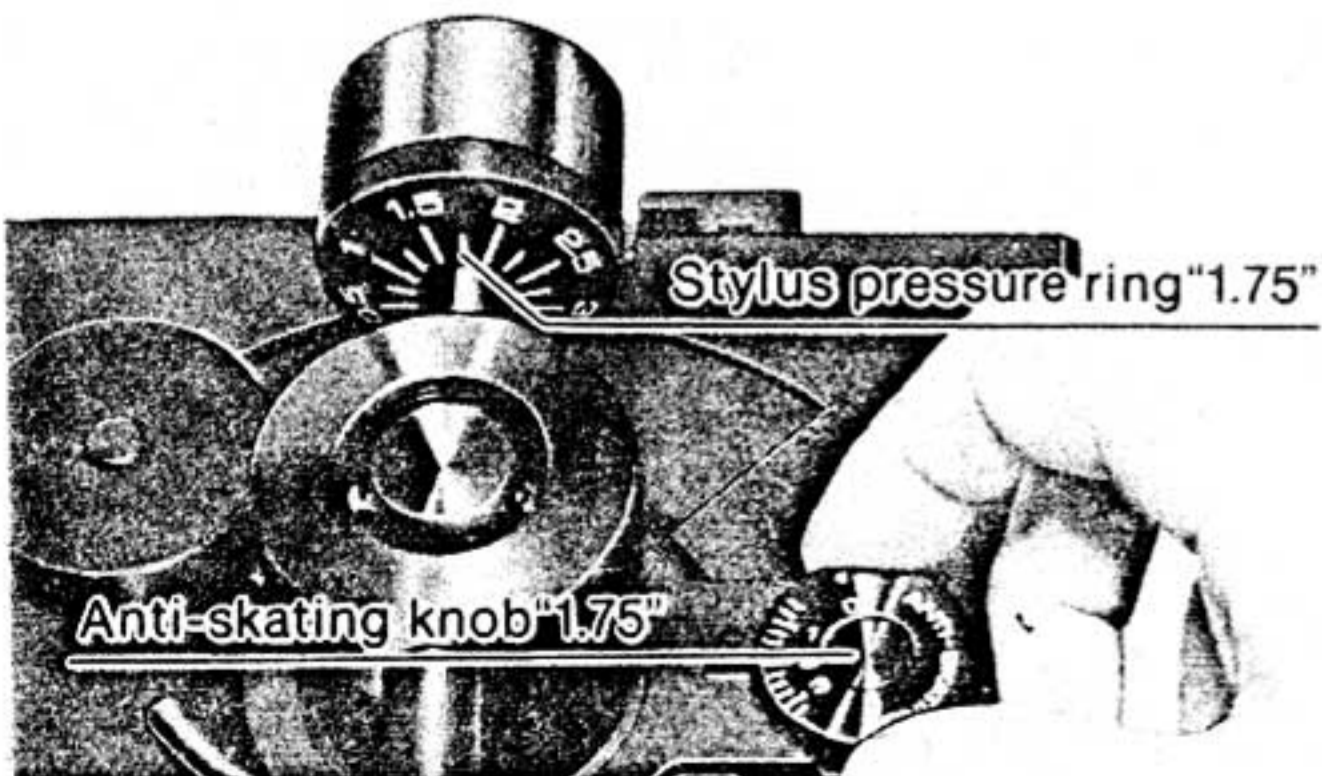

Fig. 6

- Detach the tonearm from the arm rest as shown in Fig. 3 to bring the tonearm into free state.

- Turn the entire balance weight clockwise (indicated by the arrow "A") or counterclockwise (indicated by the arrow "B") until the tonearm is approximately balanced horizontally. (See Fig. 2) During the above adjustment, be sure that the stylus tip of the cartridge does not contact the turntable mat or player case.

- After adjusting the horizontal balance, temporarily set the tubular arm in the arm rest, and then rotate only the calibrated stylus pressure ring, taking care not to move the balance weight, so as to bring the number "0" of the stylus pressure ring into alignment with the center line of the tonearm rear shaft. (See Fig. 4)

- In the next step, turn the balance weight in the direction of the arrow to align the proper stylus pressure (1.75 g) of the unit with the center line. (See Fig. 5)

Note:

- 1) Since the calibrated stylus pressure ring rotates together with the rotation of the balance weight, proper stylus pressure can be selected while you directly read the graduations of the calibrated stylus pressure ring.
- 2) In cases where the recording level of a record is extremely high or the unit is used in a room having low temperature or records are played in places where vibrations are liable to be transmitted to the record player, "distortion" of sound or "skipping" of stylus may take place. In such cases, set to "2g" for optimum performance.

3. Installation of the dust cover (Fig. 7)

Hold the dust cover at both sides, and fit it into position from directly above.

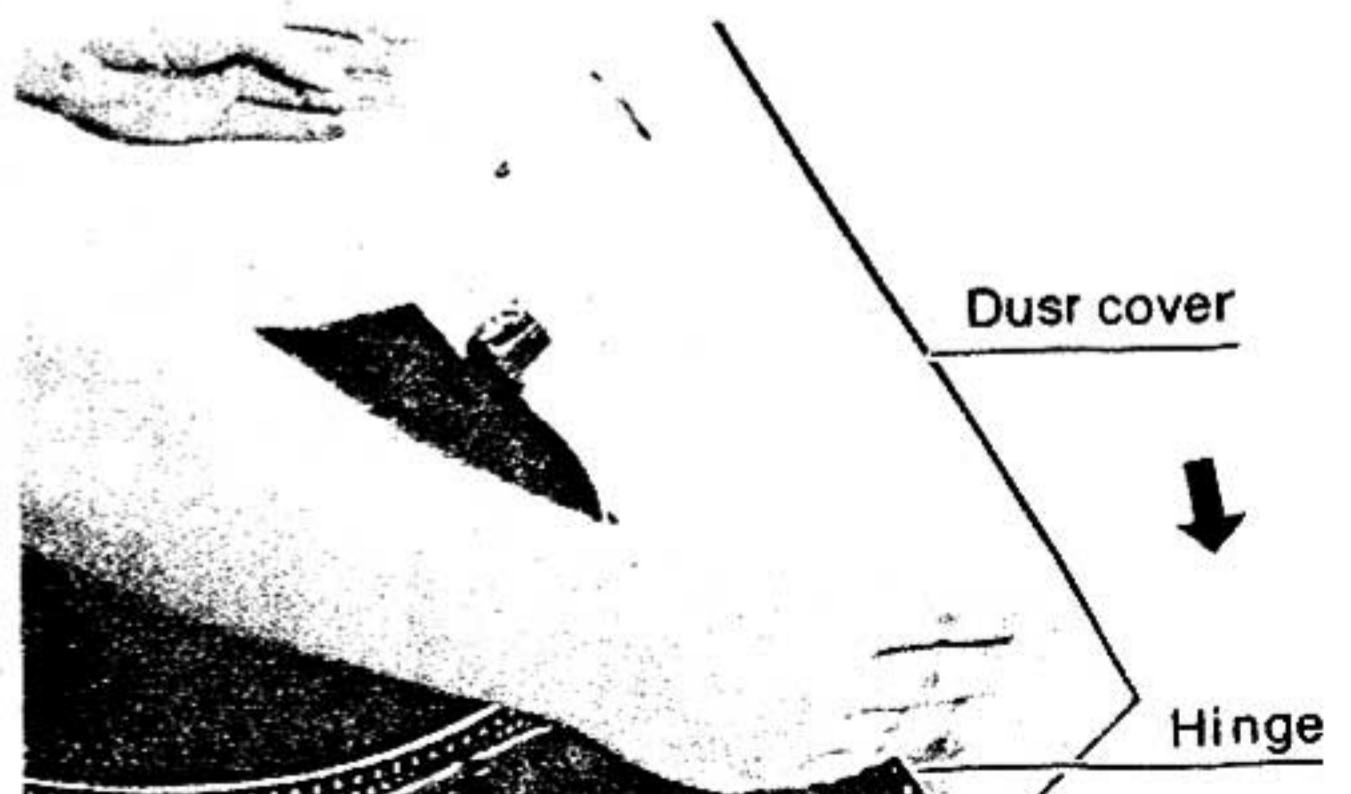

Fig. 7

TECHNICAL EXPLANATION

Outline

This player unit adopts a system that utilizes counter-electromotive force for the rotational control signal. Using a single IC chip (AN620) incorporating the main circuitry section, the size of the motor has been sharply reduced and

the player has become exceptionally slim.

The block diagram is shown below, and an explanation of the operation is given in the following.

Operation Explanation

(1) Generating coil

This coil generates a voltage whose amplitude is proportional to the rotational speed of the player.

(2) Smoothing circuit

This circuit changes the pulsating current, that has been generated by the generating coil, to a direct-current voltage with a very little ripple component.

(3) Comparison circuit

This circuit compares the voltage, which is proportional to the actual rotating speed of the player and which has passed through the smoothing circuit, with the voltage at the standard voltage circuit whose level has been established according to the rotational speed required. From this, an error voltage is produced if the compared voltages are not the same.

(4) Speed control circuit

This circuit controls the current which flows in the three differential switching circuits according to the error voltage. Also, due to the signal from the hFE compensating circuit, this circuit corrects any unbalance in the current which flows in the drive coil.

(5) Three differential switching circuits

On the secondary side of each phase of the position signal coil, an approximate 60 kHz signal that has been established by the oscillation circuit is present, and

switching is performed in the order of first phase, second phase, third phase, first phase, . . . etc. changing the current for the drive circuit. Also, this section controls the current for the drive circuit according to the current flow.

(6) Drive circuit and current limiting circuit

The drive circuit controls the large current, by a switching arrangement, that flows in the drive coil according to the small control current input.

The current limiting circuit operates to prevent the flow of current that is above the proper level in order to protect the IC from abnormal operation and the generation of heat, should overcurrent flow.

(7) hFE compensating circuit

Any variation in the hFE of the drive circuit transistors becomes a variation in the drive current, and because it influences the signal-to-noise ratio, and wow and flutter, this circuit operates to reduce the variation in hFE.

(8) Rotational speed selection and adjustment

Rotational speed selection through a change in the standard voltage and adjustments through a variation in the standard voltage can both be performed electrically.

BLOCK DIAGRAM

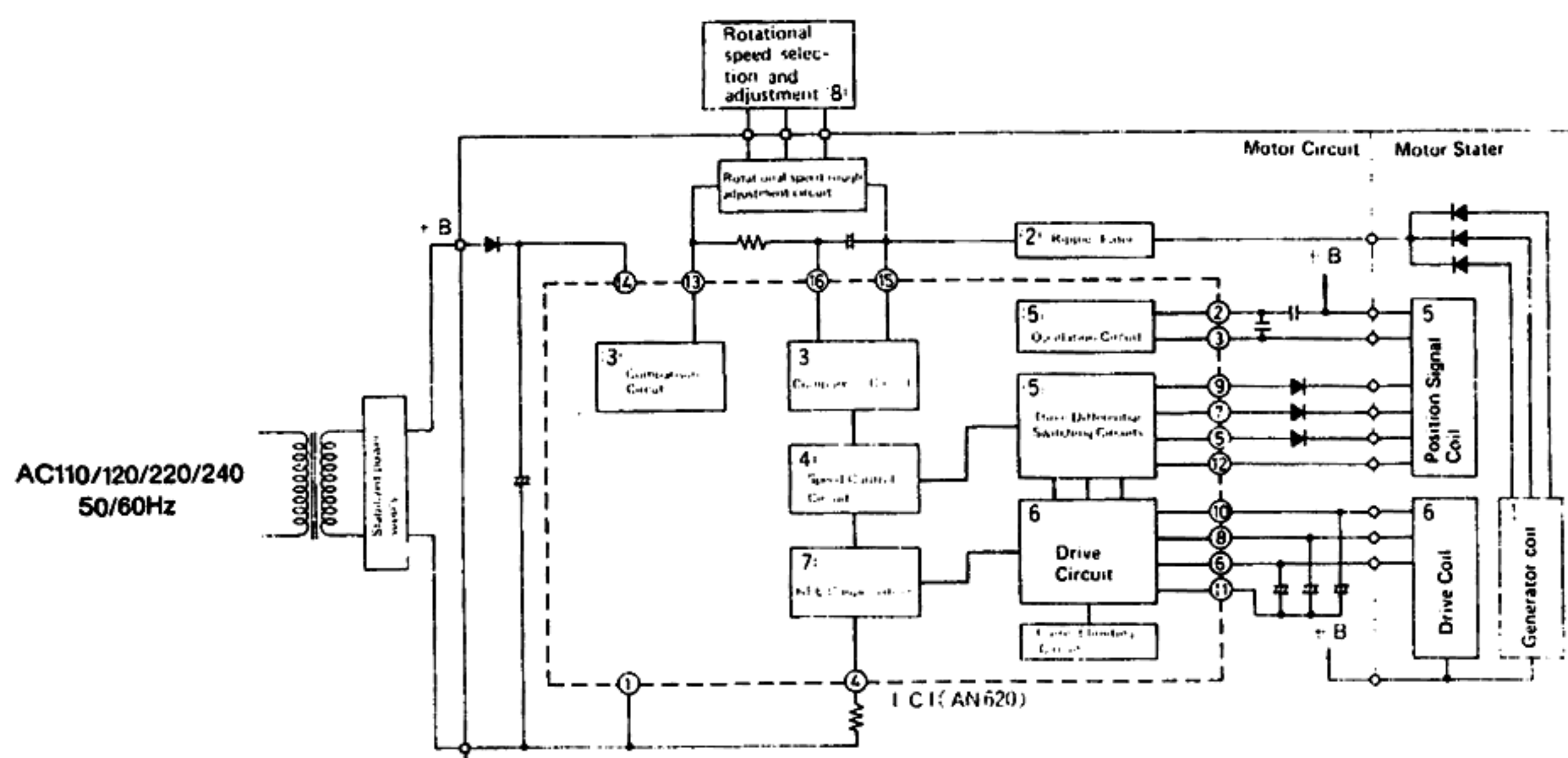

ADJUSTMENTS

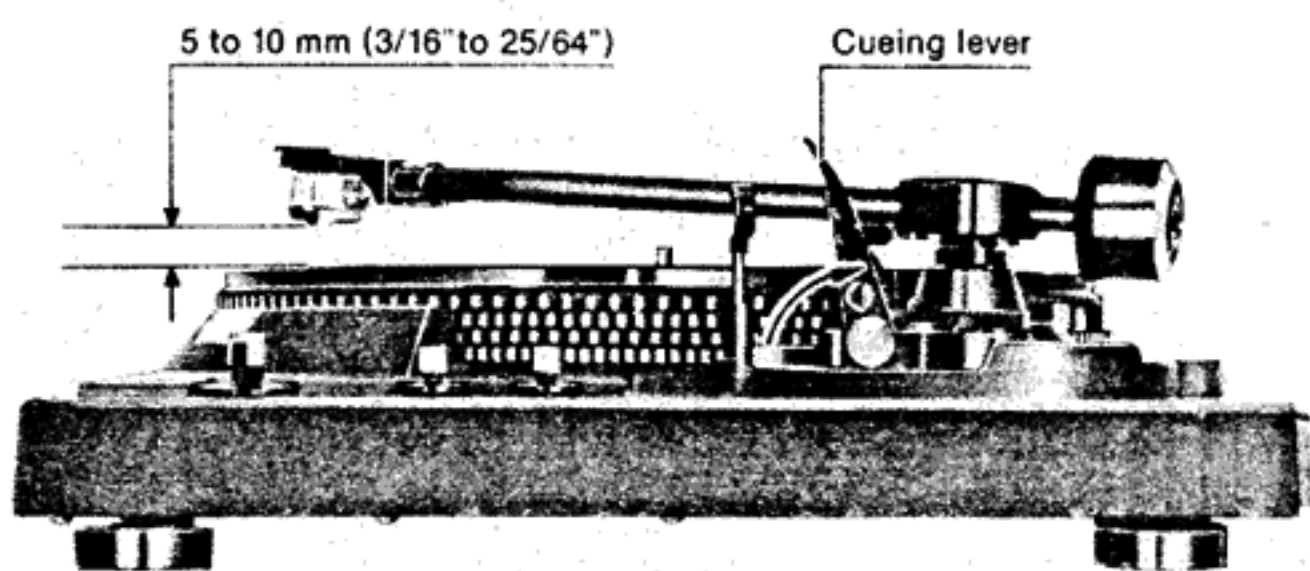

Fig. 8

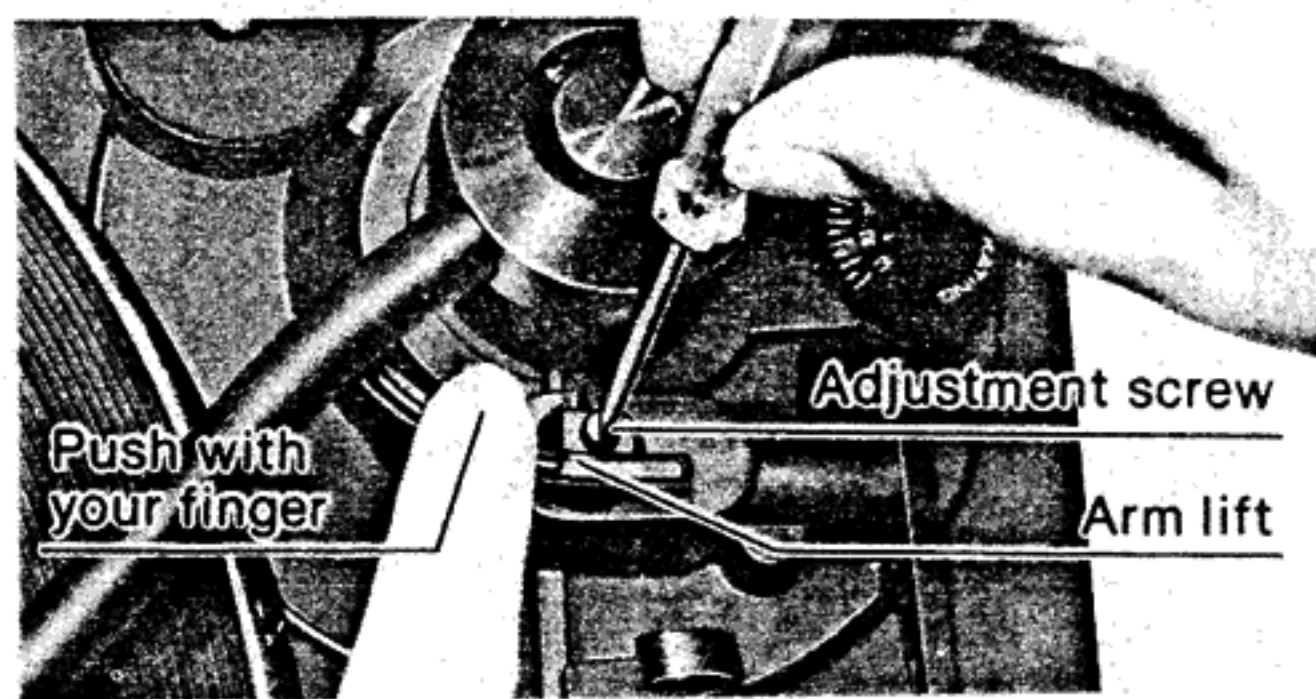

Fig. 9

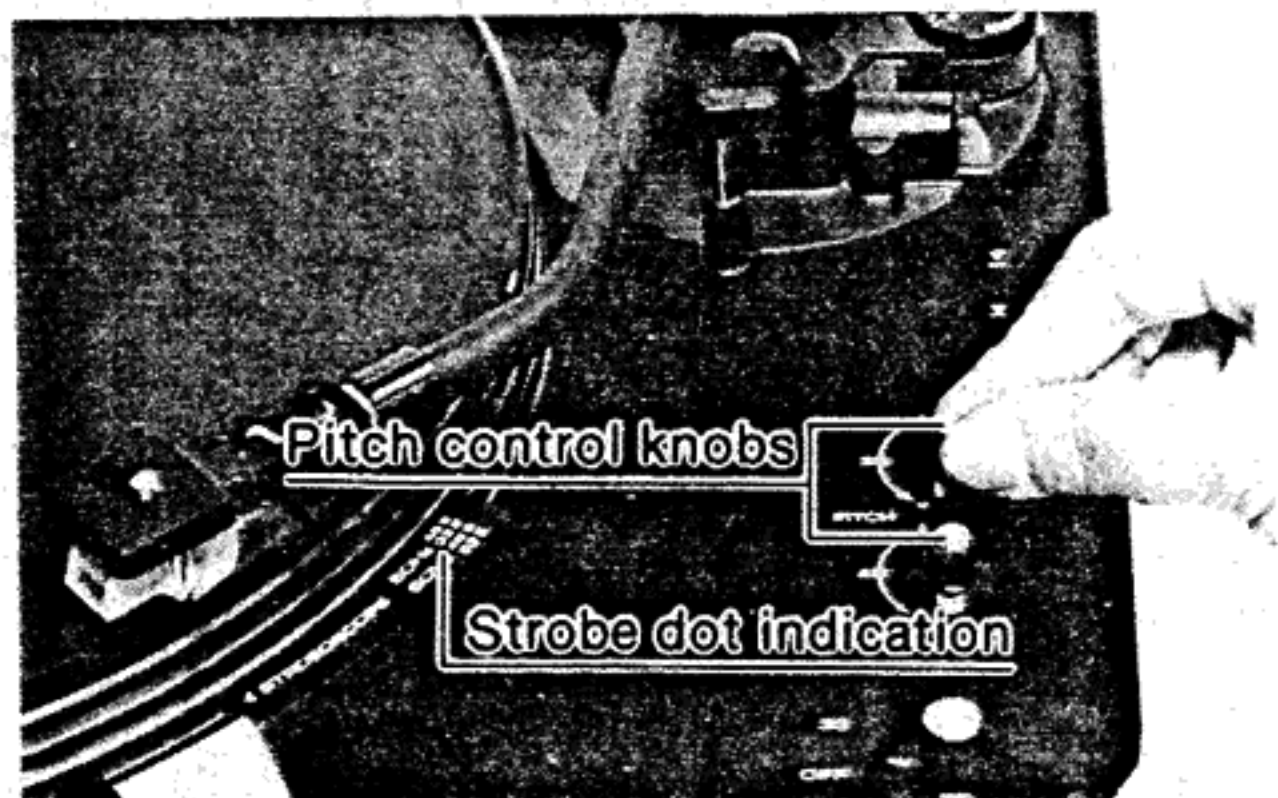
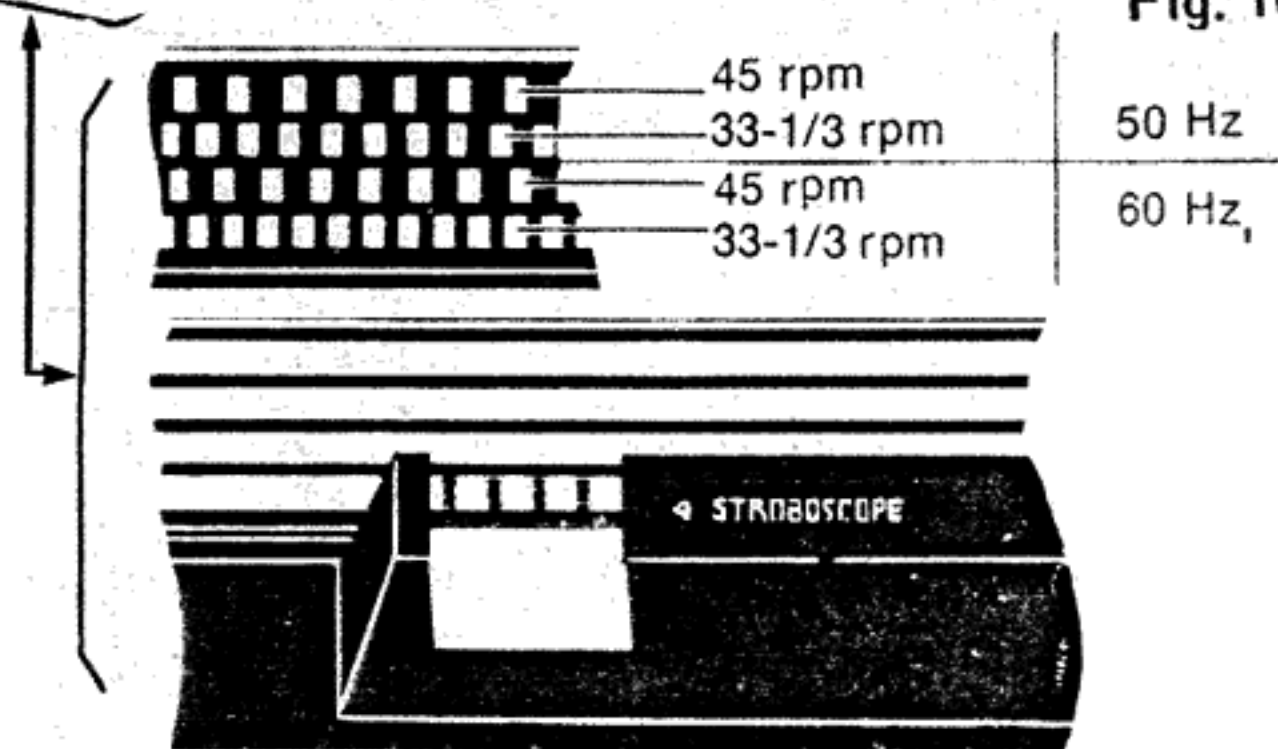

Fig. 10



Strobe of 60 Hz, 33-1/3 rpm
The strobe dots seem to be stationary.

Fig. 11

"+" direction

This increases the speed of the turntable rotation, and the strobe dot pattern seems to flow in the same direction as the rotational direction of the turntable platter.

"-" direction

This decreases the speed of the turntable rotation, resulting in a state opposite to that in the "+" direction.

1. **Adjustment of the arm lift height** (See Figs. 8 and 9)
The arm lift height (distance between the stylus tip and record surface when cueing lever is raised) has been adjusted at the factory before shipping to approximately 5 to 10 mm (3/16" to 25/64").

For using different cartridges available on the market or when further adjustments are particularly necessary, move the tonearm toward the motor shaft (center spindle), with the stylus cover put on, and then push down manually on the arm lift bar to expose the adjustment screw. Turn the screw for adjustment.

- **Clockwise rotation**
—distance between the record and stylus tip is reduced.
- **Counterclockwise rotation**
—distance between the record and stylus tip increases.

Note:

Since the adjustment screw has a hexagonal head, be sure to turn the screw while depressing the arm lift bar.

2. **Fine adjustments of speed** (Figs. 10 and 11)

Strobe dots are set on the rim of the turntable platter according to the power frequency and the number of revolutions of the records. If the strobe dots seem to be flowing, make adjustment, referring to the following points while playing a record.

Set the power switch/speed selector to the number of revolutions to be adjusted.

The strobe illuminator/pilot lamp will be lit for illuminating the strobe dots.

While turning the pitch control knobs either to "+" side or to "-" side, adjust to such an extent that the strobe dots of the turntable look as if they were stationary as in Fig. 11. The state under which the strobe dots seem to be stationary represents the correct number of revolutions.

Note:

Strobe dot pattern

The strobe illuminator/pilot lamp of this unit employs the commercially available power source. The frequency of such power source, when actually measured, has a fluctuation of about 0.2%. As such a fluctuation of the power source affects the strobe illuminator, the strobe dot pattern also seems to fluctuate to a certain extent. But the number of revolutions is not affected by the fluctuations of the power source, since a DC motor is employed in the unit.

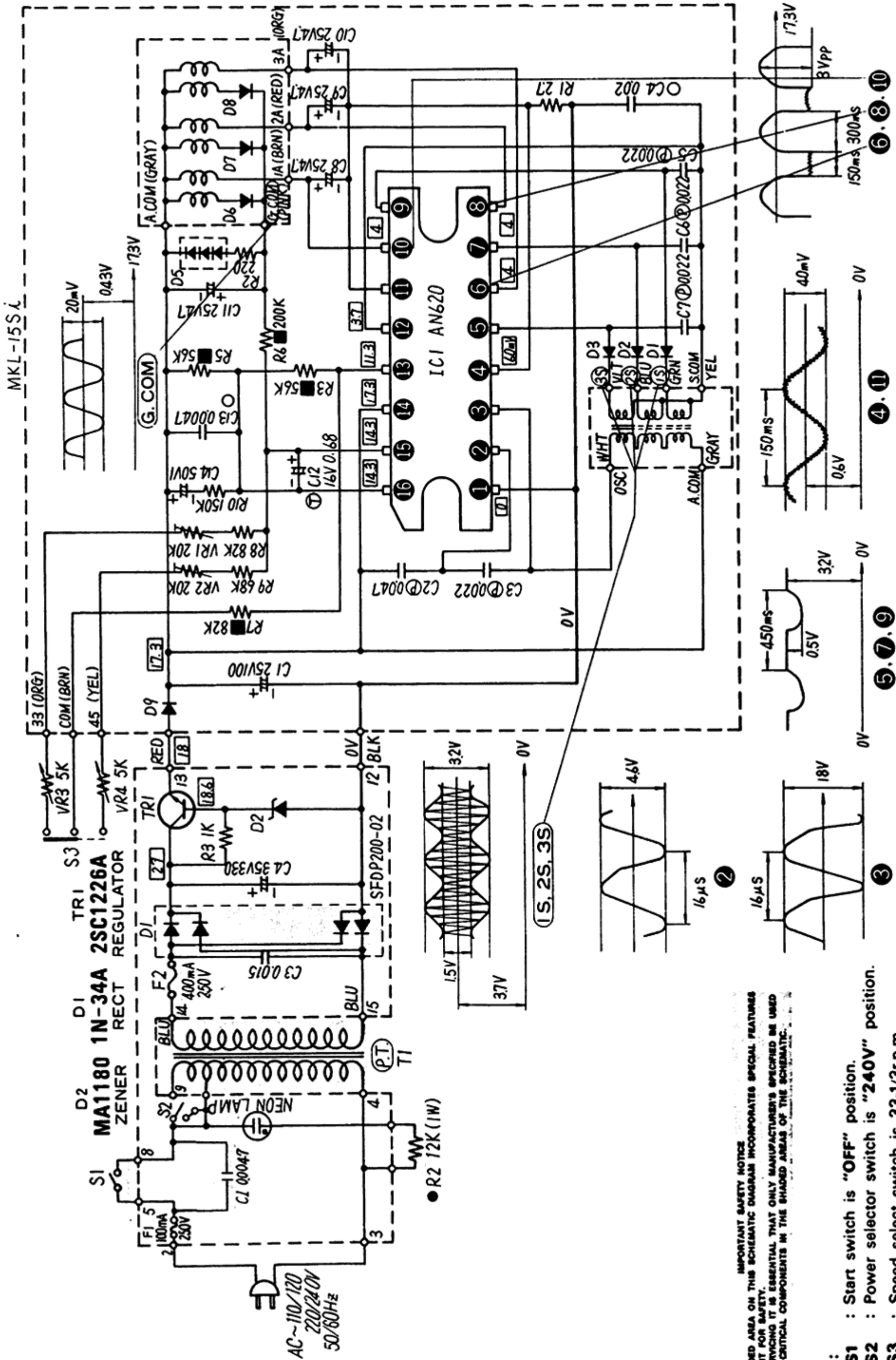

IMPORTANT SAFETY NOTICE
THE SHADED AREA ON THIS SCHEMATIC DIAGRAM INCORPORATES SPECIAL FEATURES IMPORTANT FOR SAFETY. WHEN SERVICING IT IS ESSENTIAL THAT ONLY MANUFACTURER'S SPECIFIED BE USED FOR THE CRITICAL COMPONENTS IN THE SHADED AREAS OF THE SCHEMATIC.

- NOTE :**
- 1. S1 : Start switch is "OFF" position.
 - 2. S2 : Power selector switch is "240V" position.
 - 3. S3 : Speed select switch is 33-1/3r.p.m position.

4. The voltage values entered are the values measured from the chassis with a standard tester that has an internal resistance of 100 KΩ/V at a rotational speed of 33-1/3r.p.m.

■ CIRCUIT BOARD WIRING VIEWMODEL SL-2000

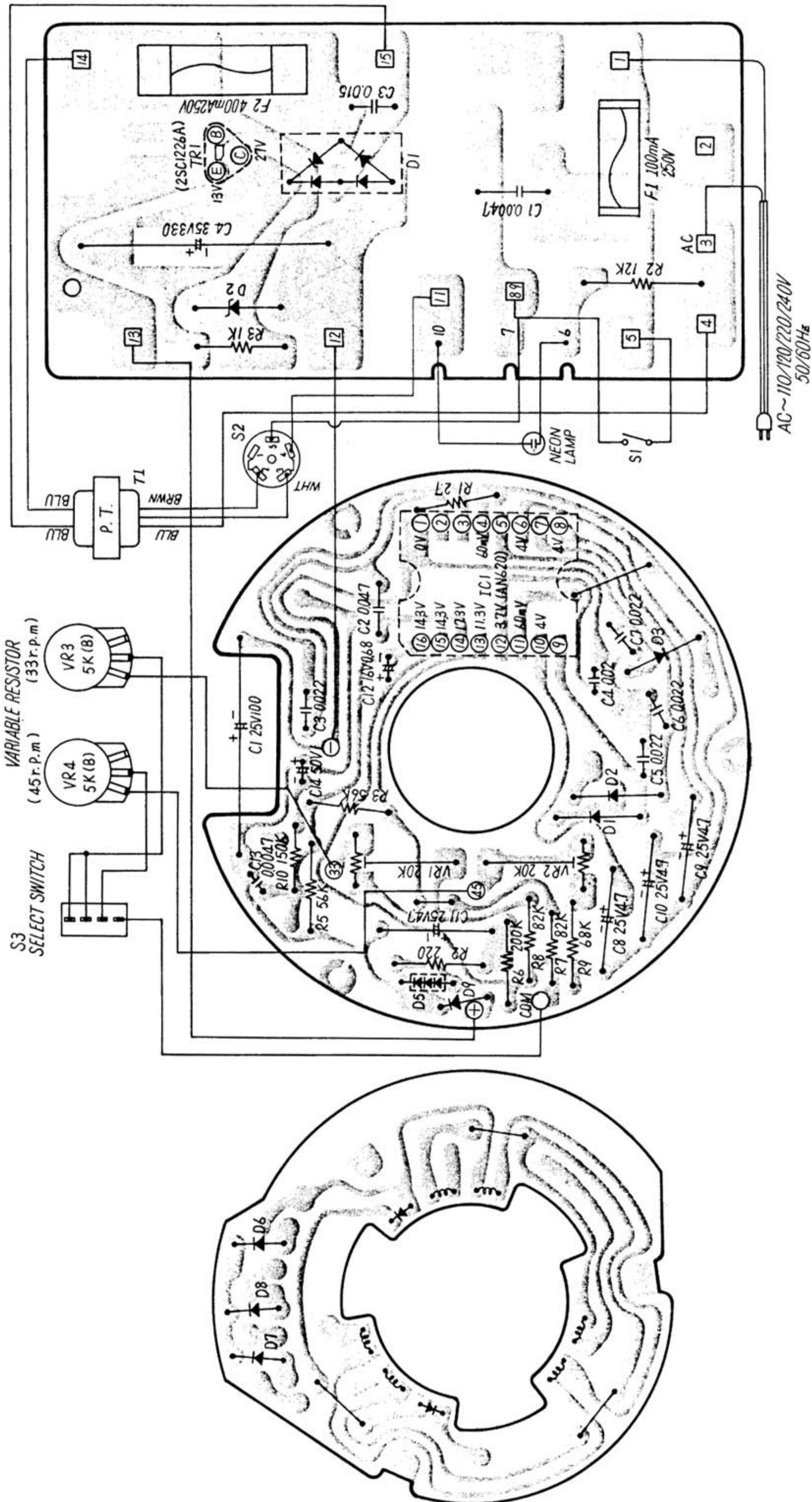

EXPLODED VIEW OF PLAYER

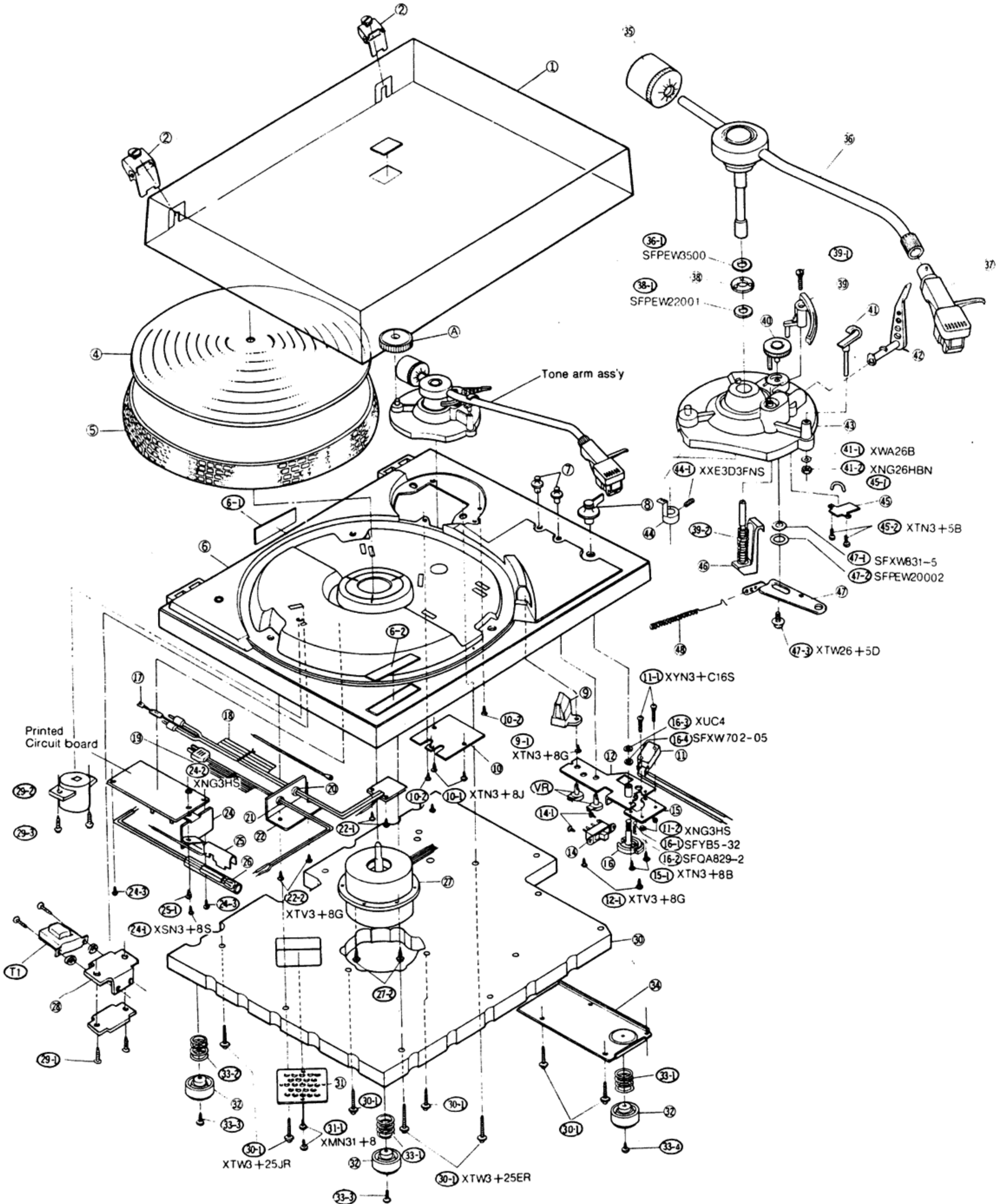

REPLACEMENT PARTS LIST

Important Safety Notice

Components identified by shaded area have special characteristics important for safety. When replacing any of these components use only manufacturer's specified parts.

NOTE: 1. Part numbers are indicated on most mechanical parts.
Please use this part number for parts orders.

Ref. No.	Part No.	Part Name & Description	Per Set	Remarks
TRANSISTORS				
TR1	2SC1226A-Q	Transistor	1	
DIODES				
D1	SVDSIRB10	Diode	1	
D2	MA1180	Diode	1	
TRANSFORMERS				
T1	MPT018	Power Transformer	1	
VARIABLE RESISTORS				
Vs, a	EVHCTA091B53	5k Ω , Speed Adjustment	2	
FUSES				
F1	XBA2C01TR0	100mA (Fuse)	1	
F2	XBA2C04TR0	400mA (Fuse)	1	
RESISTORS				
R2	ERG1ANJ123	12k Ω , 1W, \pm 5%, Metallic	1	
R3	ERD25TJ102	1k Ω , 1/4W, \pm 5%, Carbon	1	
CAPASITORS				
C1	ECKDDS472ME	0.0047 μ F 250V \pm 20%, Ceramic	1	
C2	ECOM05153K7	0.015 μ F 50WV \pm 10%, Polyester	1	
C4	ECFB35V330	330 μ F 35WV \pm 10%, Electrolytic	1	
CABINET AND CHASSIS PARTS				
1	SFAD200-01R	Dust Cover	1	○
2	SFAT200-01A	Hinge Ass'y	2	○
4	SFTG140-01	Turntable Mat	1	○
5	SFTE200-01	Turntable	1	
6	SFAC200-01	Cabinet	1	○
6-1	SFNN200X01	Name Plate, set for [XGE, E1]	1	○
6-1	SFNN200E01	Name Plate, set for [E]	1	○
6-2	SFKK200X01	Name Plate, Cabinet	1	○
7	SFKT200-01E	Knob, Variable Pitch Control	2	○
8	SFKT200-02F	Knob, Start Switch	1	○
9	SFUM200-02	Neon Cover	1	○
9-1	XIN-F8K	Screw	1	○
10	SFOP200-02	Shield Cover, PU	1	○
10-1	XTV3+8G	Screw	2	○
10-2	XTV3+8L	Screw	3	
11	VIA445	Micro Switch	1	
11-1	XYN3+C16S	Screw	2	

Ref. No.	Part No.	Part Name & Description	Per Set	Remarks
11-2	XNG3HS	Nut	2	
12	SFUP200-07E	Mounting Plate, Switch	1	○
12-1	XTV3+8B	Screw	2	
14	SFDSSW315-1	Speed Select Switch	1	
14-1	XTN3+6B	Screw	2	
15	SFUP200-08	Base, Switch	1	○
15-1	XTN3+8B	Screw	2	
16	SFUM200-03	Cam, Selector	1	○
16-1	SFYB5-32	Ball	1	
16-2	SFQA829-2	Spring	1	
16-3	XUC4	E-Shaped	1	
16-4	SFXW702-05	Washer	1	
17	SFEL028-01E	Earth Cord Ass'y	1	
18	SFKP419C	Phono Cord, set for [E, EI]	1	
18	SFDH020G01E	Phone Cord, set for [XGE]	1	
19	SFEA2C2500W	AC cord, set for [XGE]	1	
19	SFKP419C	AC cord, set for [E, EI]	1	
20	SFSR4N4	Bushing, Power Cord	1	
22	SFUP200E01	Mounting Plate, Cord	1	○
22-1	XTV3+8J	Screw	2	
22-2	XTV3+8J	Screw	2	
24	SFUP200-06	Plate, Heat Sink	1	
24-1	XSN3+8S	Screw	1	
24-2	XNG3HS	Nut	1	
24-3	XTV3+8J	Screw	2	
25	SFUP200-05	Shield Plate	1	○
25-1	XTV3+8J	Screw	1	
26	SFDNE2HUWMA2	Neon	1	
27	MKL15SIT	Motor Ass'y	1	○
27-2	XTV3+8J	Screw	3	
28	SFUP200-03	Mounting Plate, Transformer		
28-1	SFGH200X01	Spacer, Power Transformer	2	○
29-1	XTV3+8J	Screw	3	
29-2	SFDSXW131-1	Power Selector Switch	1	
29-3	XTV3+8J	Screw	2	
30	SFAU200X01	Bottom Plate	1	○
30-1	XTW3+25JR	Screw	16	
31	SFUP200X01	Shield Plate, Transformer	1	○
31-1	XMM31+8	Screw	2	
32	SFGA200-01E	Audio Insulators	4	○
33-1	SFQC200-01	Spring, Insulator	2	○
33-2	SFQC200-02	Spring, Insulator	2	○
33-3	XMN31+13	Screw	3	
33-4	XTV3+8J	Screw	2	
34	SFUP200-04	Cover, Switch	1	
35	SFPWG22001K	Balance Weight Ass'y	1	
36	SFPAM20001K	Tone Arm	1	
36-1	SFEW3500	Washer	1	
37	SFPCC13001K	Head Shell	1	
37-1	EPC270C II K-X	Cartridge, set for (E, EI)	1	
37-2	SFPEV7800	Screw, set for [E, EI]	2	
38	SFUP890B01E	Bolt, Tone Arm	1	
38-1	SFPEW22001	Washer	1	
39	SFPRT22003K	Arm Lift	1	
39-1	SFXG829-1	Screw Adjustment, Arm Lift Base	1	
39-2	SFQA829-03	Spring, Arm Lift	1	
40	SFPJK20002	Anti-Skating Force Control Knob	1	○
41	SFPRT20001	Arm Rest	1	○
41-1	XWA26B	Washer	1	
41-2	XNG26HBN	Nut	1	
42	SFPJL20001	Lever, Lift	1	○

Ref. No.	Part No.	Part Name & Description	Per Set	Remarks
43	SFPKD20001E	Arm Base	1	○
44	SFPJD22003K	Tonearm Fixing Plate Ass'y	1	
44-1	XXE3D3FNS	Screw	1	
45	SFPAB20001	Plate, Lift	1	○
45-1	SFPGM20001	Cueing Rubber	1	
45-2	XTN3+5B	Screw	2	
46	SFPJL22002K	Arm Lift Base Ass'y	1	
47	SFPSH20001	Plate, Anit-Skating	1	
47-1	SFXW831-5	Washer	1	
47-2	SFPEW20002	Washer	1	
47-3	XTW26+5D	Screw	1	
48	SFPSP12002	Spring, Canceler	1	
49	SFDZ023X01	Holder, Fuse	4	
50	EPS270ED	Stylus	1	
ACCESSORY PARTS				
A1	SFNU200G01	Printed Matter, set for [XGE]	1	○
A1	SFNU200X01	Printed Matter, set for [E, E1]	1	○
A2	SFWE154A1	45 r.p.m. Adaptor	1	
A3	SFDK100G	DIN-PIN Plug	1	
PACKING MATERIALS				
P2	SFHP200G01	Packing Case (Inner), set for [XGE]	1	○
P2	SFHP200X01	Packing case, set for [E, E1]	1	○
P3	SFHH200-01	Side Pad (Front)	1	○
P4	SFHH200-02	Side Pad (Rear)	1	○
P5	SFHD200-01	Pad, Top	1	○
P6	SFHD200-02	Pad, Turntable	1	○
P7	SFHH023L05	Parts Box	1	
P8	SFHD200X01	Top, Parts Box	1	
P9	SFYF60A60	Polyethylene Sheet	2	
P11	SFYF45A50	Polyethylene Pack	1	
P12	SFYF15A20	Polyethylene Pack	1	
P13	SFYC22A26	Polyethylene Sheet	1	
<p>Set for [XGE] is England. Set for [E1] are European. Set for [E] are Scandinavian.</p>				

■ PACKING PARTS

