

TEAC

SERVICE MANUAL X-1000R



<http://www.ebaman.com>

1 SPECIFICATIONS AND SERVICE DATA

SPECIFICATIONS

Track System ¼-track, 2-channel stereo

Head System

6 heads: forward erase, forward record, reverse playback, forward playback, reverse record, reverse erase.

Reel Size 10-½ and 7"

Tape Speed 19cm/s (7-½ ips) and 9.5cm/s (3-¾ ips)

Inputs (level and impedance)

MIC: Specified input level: -60dB (0.775mV)/10kohms
Min. input level: -70dB (245µV)

LINE IN: Specified input level: -12dB (195mV)/50kohms
Min. input level: -22dB (61.5mV)

Outputs (level and impedance)

OUTPUT: Specified output level: -5dB (436mV)/10kohms
Max. output level: +1dB (0.869V)

PHONES: Specified output level: -24dB (48.9mV)/8ohms

Playback equalization

"LH" tape: 19cm/s: 3,180µs + 50µs (NAB)
9.5cm/s: 3,180µs + 90µs (NAB)

"EE" tape: 19cm/s: 3,180µs + 35µs
9.5cm/s: 3,180µs + 50µs

Motors

Capstan motor: FG servo DC motor
Reel motor: 2 DC slotless motors

Bias Frequency 100kHz

Power Requirements

100/120/220/240V, AC 50/60Hz 90W (General export model)
220V AC 50Hz, 100W (Europe model)
240V AC 50Hz, 100W (U.K./Australia model)
120V AC 60Hz, 90W (U.S.A./Canada model)

Weight 22.0kg (48-8/16 lbs) net

26kg (57-5/16 lbs) (with wooden case)

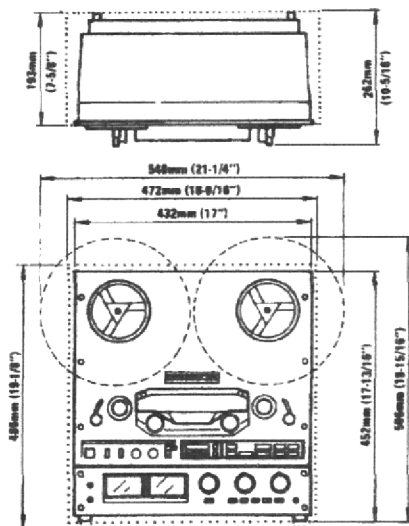

Broken line indicates General Export Models for Limited Areas.

Fig. 1-1 Dimensions

SERVICE DATA

MECHANICAL

Tape Speed Deviation 3,000Hz ± 30Hz

Tape Speed Drift 15Hz

FWD/REV Tape Speed Differential 30Hz

Wow and Flutter

Playback: 0.05% (WRMS), 0.10% (RMS) at 19cm/s
0.07% (WRMS), 0.12% (RMS) at 9.5cm/s

Record/Playback: 0.12% (RMS) at 19cm/s
0.15% (RMS) at 9.5cm/s

Pinch Roller Pressure 1.35kg ~ 1.9kg (3.0 lbs ~ 4.2 lbs)

Tape Tension

Play mode:

Take-up: 50g ± 10g (1.4oz ~ 2.1oz)

Supply: 50g ± 10g (1.4oz ~ 2.1oz)

Fast winding mode

Take-up: 110g ± 10g (3.5oz ~ 4.2oz)

Supply: _____

Brake Torque

Forward direction: 1.2 ~ 1.7kg-cm (17 ~ 24oz-inch)

Reverse direction: 0.6kg-cm (8.3oz-inch) or less

Left/right deviation: 0.2kg-cm (2.8oz-inch) or less

Fast Winding Time 80 seconds or less for 550m (1800 feet)

Pitch Control Standard tape speed ±6% or more

FWD/REV Change Time 3.5 sec. ± 0.5 sec.

TIMER Activate Time 4 sec. ± 2 sec.

ELECTRICAL

Frequency Response

See Fig. 3-5 to 3-10

Signal to Noise Ratio

Playback: 50dB min. (19cm/s, LH)

52dB min. (19cm/s, EE)

49dB min. (9.5cm/s, LH)

52dB min. (9.5cm/s, EE)

Overall: 48dB min. (19cm/s, LH)

50dB min. (19cm/s, EE)

46dB min. (9.5cm/s, LH)

50dB min. (9.5cm/s, EE)

Overall (dbx): 65dB min. (Both speeds, various tapes)

Erase Efficiency 68dB min. at 1kHz (measured with input 10dB higher than the specified input level)

Channel Separation 50dB min. at 1kHz

Adjacent Track Crosstalk 40dB min. at 125Hz

Total Harmonic Distortion At 1kHz, and at 19cm/s

0.8% or less

0.8% or less (dbx 1N)

3% or less (dbx 1N + 20VU)

• Improvements may result in SPECIFICATIONS AND SERVICE DATA changes.

• Value of "dB" in the data refers to 0dB (0.775V), except where specified.

2 MECHANICAL ADJUSTMENTS AND CHECKS

2-1 ROTATING PART THRUST CLEARANCE CHECKS

Reference values

Capstan shaft:	0.1mm to 0.25mm (magnefloat type)
Inertia roller:	0.05mm to 0.3mm
Tension arm guide roller:	0.05mm to 0.3mm
Reel motor:	0 (spring type)
Tension arm:	0 (spring type)

NOTE: Since the capstan shaft is a magnefloat type, check that it is forced towards the rear of the deck while rotating.

2-2 CAPSTAN MOTOR REPLACEMENT

1. When the capstan motor is replaced, install it with its lead wires and washers as shown.
2. Check that, when the deck is operated by repeating the forward and reverse play modes, the capstan drive belt changes position on the flywheels smoothly.

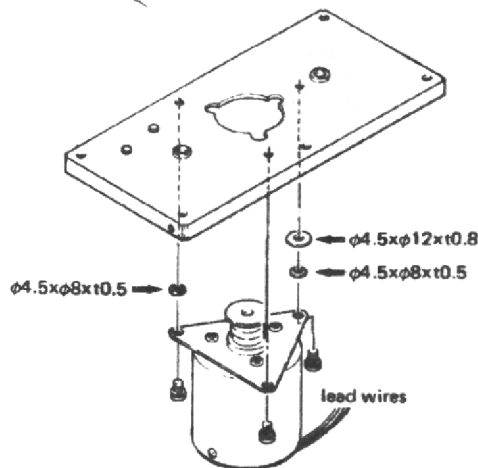

Fig. 2-1

2-3 BRAKE ADJUSTMENT

NOTE: The explanation and figure in this paragraph are for the left side brake, similar checks and adjustments are applicable for the right side one.

1. Adjust by moving the brake band bracket in either direction (arrow (A)) so that the reel motor chassis is in parallel with the brake arm, and so that the brake band makes proper clearance equally all around the reel table base.
2. Adjust by moving the brake solenoid in either direction (arrow (D)) so that the stroke of the solenoid plunger is about 2mm.
3. Adjust by moving the band ass'y retaining plate as shown in (B, C, E) so that, when the plunger is pushed in the direction of the solenoid housing, the reel table base is not rubbed by the brake band and is properly spaced.

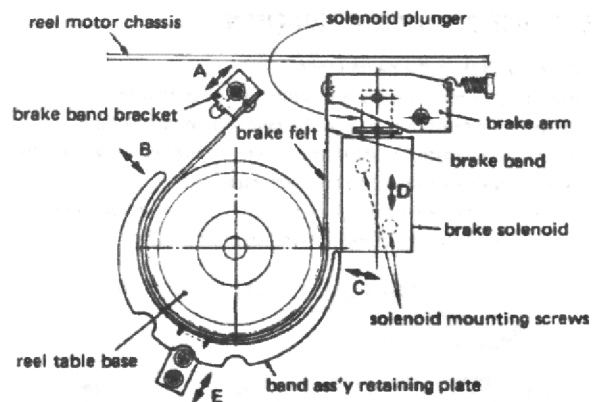
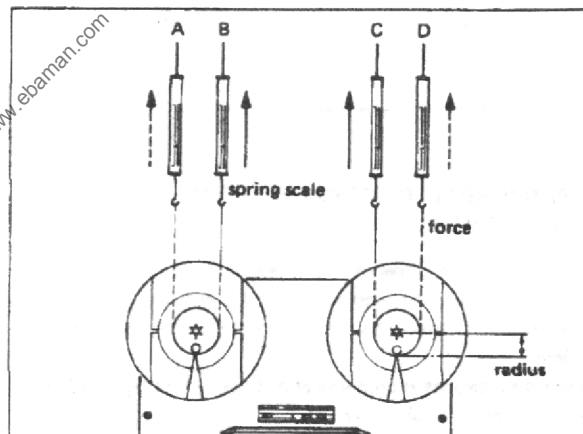

Fig. 2-2

2-4 BRAKE TORQUE MEASUREMENT

1. Place an empty 7" reel, connected to a spring scale by a string, on the reel table.
2. Pull the scale away from the reel and read the scale indication only when the reel table is steady motion.
3. Do steps 1 and 2 for each measuring condition, (A) through (D) in Fig. 2-3.
4. The values are as chart in Fig. 2-3.



↑ Forward direction (B) (C)	1.2 to 1.7kg-cm (17 to 24oz-inch)
↑ Reverse direction (A) (D)	0.6kg-cm (8.3oz-inch) or less
Left/right deviation	0.2kg-cm (2.8oz-inch) or less

- NOTES:**
1. The reverse direction values are reference.
 2. The specification of left/right deviation only applies for forward direction torques.

Torque calculating formulas:

- (1) Torque (in g-cm or oz-inch)
= Force or Weight (in g or oz) x Radius (in cm or inch)
- (2) Conversion of g-cm to oz-inch:
g-cm x 0.0138 = oz-inch

Fig. 2-3

2-5 PAUSE POSITION ADJUSTMENT

1. Place the deck in the pause mode.
2. Adjust by turning the pause positioning nut so that the clearance between the capstan shaft and the tape is 0.5mm to 1.0mm.
3. Of the two capstan shaft/pinch rollers, adjustment is allowable only for the side having the narrower clearance.
4. Check that, by repetition of play mode to pause mode and stop mode to pause mode, there is clearance at both sides.

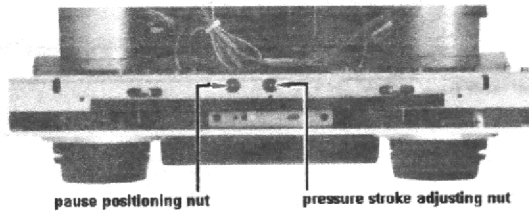

Fig. 2-4 Pause position and pinch roller pressure stroke adjustments

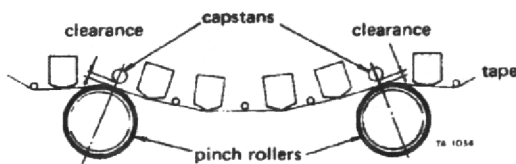
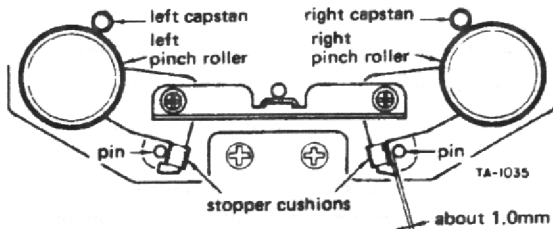

Fig. 2-5 Pause position adjustment

2-6 PINCH ROLLER PRESSURE STROKE ADJUSTMENT

1. Set the deck in the forward or reverse play mode.
2. Adjust by turning the pressure stroke adj. nut (Fig. 2-4) so that the clearance between the pin and the stopper cushion is about 1.0mm.
3. Since the clearance is produced at one side (left or right), adjustment for this side only is permissible.



Either the left or right should have a clearance of about 1.0mm.

Fig. 2-6

2-7 PINCH ROLLER PRESSURE MEASUREMENT

NOTES: 1. The explanation below applies to both the left and right pinch rollers.

2. Both pinch roller pressures are automatically set with equal value.

1. Hold both the left and right tension arms in the upper positions using rubber bands, string etc.
2. Set the deck in either play mode with no tape loaded.
3. Attach the spring scale to the pinch roller as shown in the figure.
4. Draw the pinch roller away from the capstan shaft (in the direction of a line intersecting the centers of the capstan shaft and the pinch roller) until the capstan shaft and the pinch roller are separated.
5. Return the scale back until the pinch roller just begins to turn. The scale should then be reading as follow.
Reference value: 1.35kg to 1.9kg (3.0 lbs to 4.2 lbs)
6. If the reading is out of specification, replace defective part(s). There are no adjustable parts.

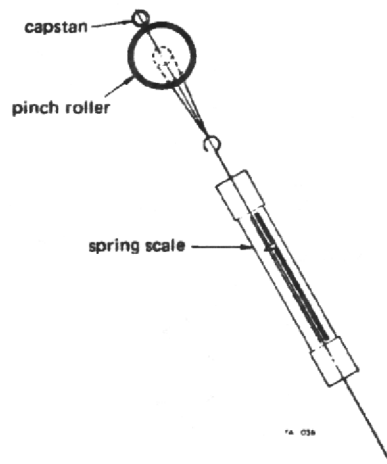

Fig. 2-7

2-8 TAPE TENSION

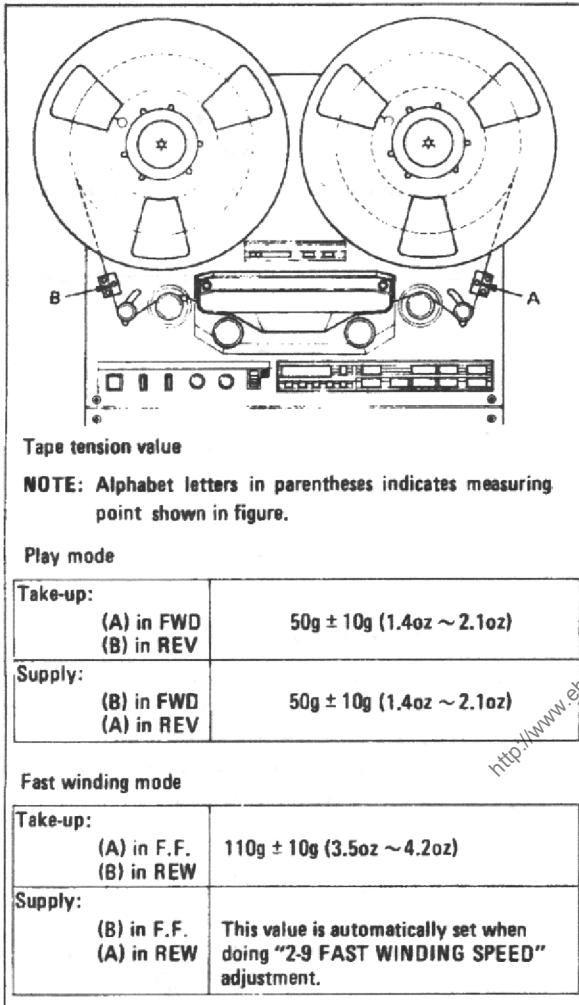

Fig. 2-8

- NOTES:**
- Since these settings are precisely factory adjusted, in general, they should not be re-adjusted. If it is specifically required, a special meter is needed.
 - To facilitate adjustment, the deck should be placed in a vertical position.
 - For the reels mounted on both left and right reel tables, use the same size ones.
 - Before all the following adjustments (2-8-1 ~ 2-8-4), perform next instructions in order to activate the relevant circuit.
 - Thread the tape to lift up both tension/shut-off arms.
 - Set the POWER switch to ON.
 - Leave the deck as it is for 5 to 10 minutes.
 - There should be almost equal values between tape tension at point A during fast forward mode and at point B during rewind mode.

2-8-1 IN FORWARD PLAY

- Place a reel loading TEAC YTT-8013 test tape on the left reel table and an empty reel on the right reel table, then thread the tape.
- Let the tape run in fast forward mode until both reels have nearly the same tape winding diameter.
- During forward play with a tape speed of 3-3/4ips (9.5cm/s), measure tape tension at point A.
- Adjust R120 so that the specified tape tension of 50g ± 10g (1.4oz ~ 2.1oz) is obtained.

2-8-2 IN REVERSE PLAY

(Continued from step 4 above)

- Let both reels have the same amount of tape wound on them.
- During reverse play with a tape speed of 3-3/4ips, adjust R220 to get a specified tape tension of 50g ± 10g (1.4oz ~ 2.1oz) at point B.

2-8-3 IN FAST FORWARD

- Load a TEAC YTT-8013 test tape on the left reel table and an empty reel on the right reel table, then thread the tape.
- Stop the left reel by hand and set the deck in fast forward mode.
- Adjust R237 to obtain a 100g to 120g (3.5oz ~ 4.2oz) value at point A (Obtain a 100g or 3.0oz value as far as possible).

2-8-4 IN REWIND

- Load a TEAC YTT-8013 test tape on the right reel table and the empty reel on the left reel table, then thread the tape.
- Stop the right reel by hand and set the deck in the rewind mode.
- Adjust R238 to obtain a 100g to 120g (3.0oz ~ 3.6oz) value at point B (Obtain a 100g or 3.5oz as far as possible).

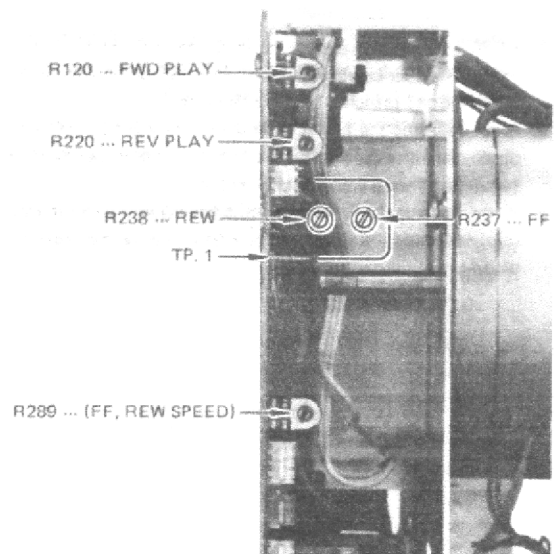

Fig. 2-9 Tape tension adjuster location

2-9 FAST WINDING SPEED

1. Set the deck in vertical position.
2. Connect oscilloscope between TP1 test point on the POWER SERVO PCB and ground.
3. Thread a TEA YTT-8013 test tape. In this case, either use of 7 inch reels or 10 inch are permitted provided both left and right reels are the same size.
4. During fast forward or rewind mode, adjust R289 so that wavelength displayed on the oscilloscope becomes 7msec. Adjustment should be satisfied at any tape winding position.
5. Check that almost equal value of fast winding speed is obtained between fast forward and rewind modes.

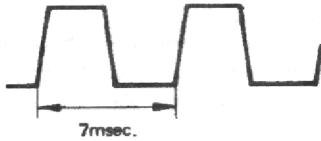

Fig. 2-10 Waveform at TP1

2-10 TENSION ARM HEIGHT ADJUSTMENT

1. Thread any standard tape on the deck using a standard empty reels such as TEAC RE-1002.
2. Set the deck in the forward or reverse play mode.
3. Stop left (right) inertia roller's rotation by hand. Adjust by turning the left (right) tension arm height adjusting nut (refer to Fig. 2-11) so that the tape moves in the center of the inertia roller.

NOTE: When adjusting, pay special attention to the relationship between position-detecting shutter and the opening of photo-interrupter to prevent, for example, the shutter from being caught.

4. Release the inertia roller. Fine-adjust the adjusting nut again until there is no tape curling on the tape guide pin between the erase head and the left (right) inertia roller.
5. After Adjusting the height of both left and right tension arms, check that the tape running condition is good by switching between fast forward and rewind modes.
6. If the tape running position is different when the inertia roller stops and when it turns, the condition when the inertia roller is rotating has priority.

Figure shows left side tension arm.

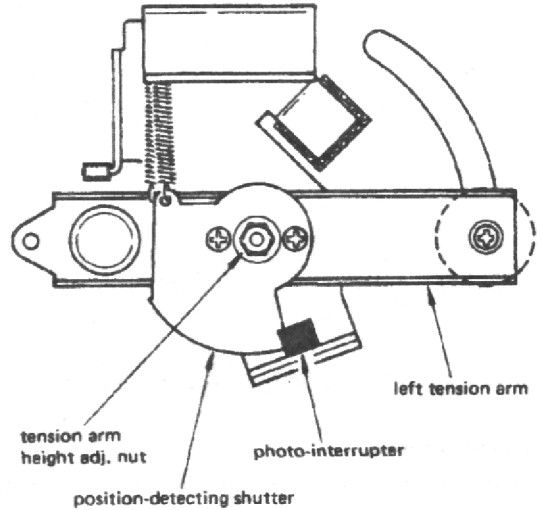

Fig. 2-11

2-11 REEL TABLE HEIGHT ADJUSTMENT

1. Adjust the tension arm height beforehand (See 2-10).
2. Check each reel table height using a TEAC RE-1002 empty reel and letting the tape run in each tape operating mode.
3. If the tape rubs against the reel flanges, adjust the reel table height by means of the two reel table mounting screws.

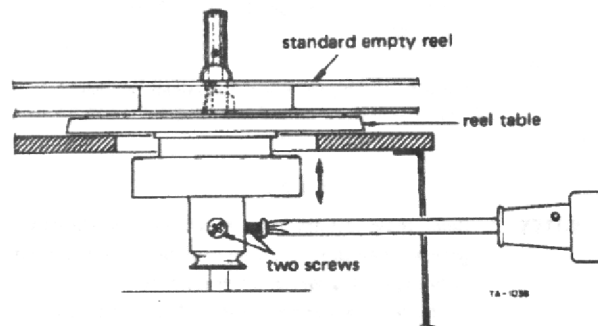

Fig. 2-12

2-12 HEAD AND TAPE PATH ALIGNMENTS

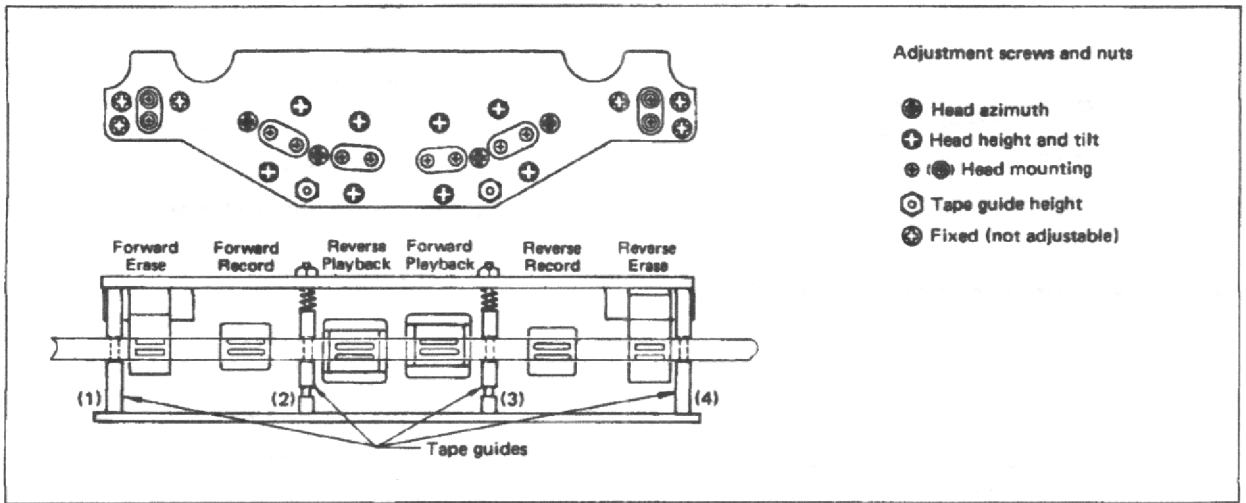

Fig. 2-13 Tape guide and head arrangement

<p>TILT</p> <p>The head surface should be parallel to the tape guide pin surface.</p>	
<p>AZIMUTH</p> <p>The gap of the head core should be perpendicular to the tape travel.</p>	
<p>HEIGHT</p> <p>The upper (lower) core of the head should be level with the upper (lower) edge of the tape.</p>	
<p>TANGENCY</p> <p>The dotted line should be perpendicular to the surface of the tape.</p>	

Fig. 2-14 Head regulation elements

2-12-1 COARSE ADJUSTMENT OF PINCH ROLLER PARALLELISM

The following procedure is for parallelism adjustment of left pinch roller. A similar procedure is also applied for the right pinch roller.

1. Let pinch roller draw near toward capstan shaft by manually lifting up tape lifter shown in Fig. 2-15.
2. Check pinch roller/capstan shaft parallelism viewed from direction of arrow A shown in Fig. 2-15. Refer to Fig. 2-16.

If not parallel, loosen the reinforcement plate screw near the correction-required side (Refer to Fig. 2-18), then correct tilt of pinch roller spindle using correction jig. Adjustment can be done by tilting correction jig in direction of arrow A or A'.

NOTE:

- (1) Use the jig as near as possible to the pinch roller spindle.
- (2) Do not touch the surface of spindle.
- (3) Use no other tool for this adjustment!
4. Remove pinch roller, then push up tape lifter to visually align pinch roller spindle with the capstan shaft viewed from direction of arrow B in Fig. 2-15.
5. If needed, adjust by tilting correction jig in direction of arrow B or B' in Fig. 2-18.

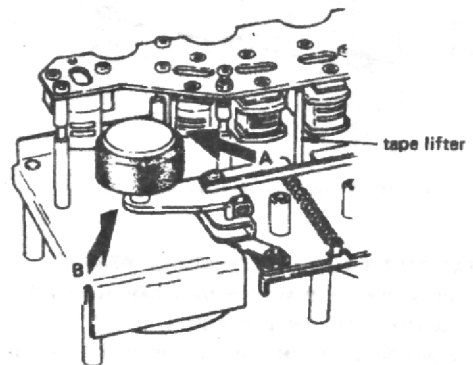

Fig. 2-15 Directions for pinch roller parallelism check

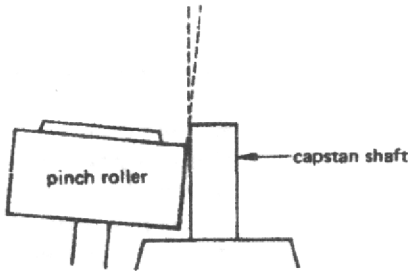

Fig. 2-16 View in direction A (example of non-parallelism)

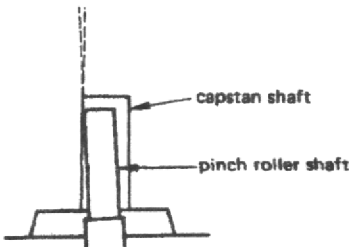

Fig. 2-17 View in direction B (example of non-parallelism)

correction jig (TEAC P/N 5736000100)

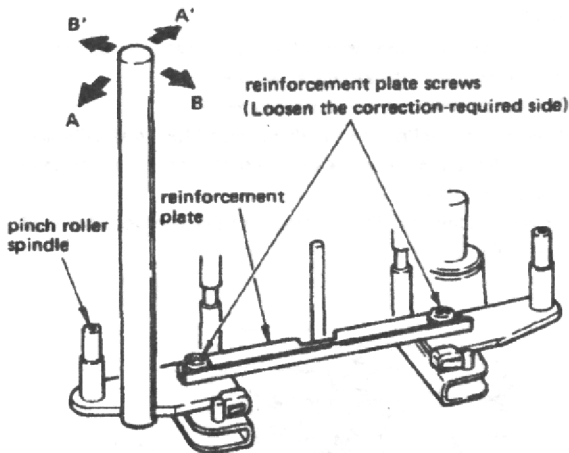

Fig. 2-18 Pinch roller/capstan alignment

2-12-2 HEAD TILT AND AZIMUTH ADJUSTMENT

1. Visually adjust the tilt of each playback head so that the head surface is parallel to the nearest tape guide.
2. Visually adjust the tilt of each record head so that the head surface is parallel to the nearest capstan shaft.
3. Make coarse azimuth adjustments for the record and playback head, viewing each head from front (without tape).

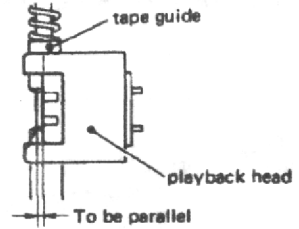

Fig. 2-19 Playback head tilt adjustment

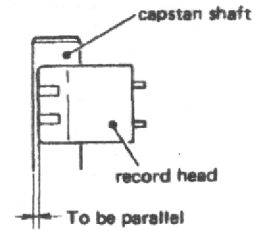

Fig. 2-20 Record head tilt adjustment

2-12-3 TAPE GUIDE HEIGHT ADJUSTMENT

1. Running a TEAC YTT-8013 test tape (thickness = 35 μ m) in the forward direction, adjust the height of the left tension arm so that the lower edge of the tape is just touching the lower edge of the tape guide (1). See Fig. 2-21. Also refer to 2-10 TENSION ARM HEIGHT ADJUSTMENT".
2. Adjust the height of the tape guide (2) so that the upper edge of the tape is in contact with the upper edge of the tape guide.
3. Confirm that the adjustments do not cause the tape to curl.
4. Apply locking paint to the height adjusting nut of the tape guide (2).
5. During reverse play, adjust height of tape guides (3) and (4) in the same way as steps 1 ~ 4. For tape guide (4), adjust right tension arm height.
6. Check to see there is no tape curling at all the tape guides in both forward and reverse play modes.

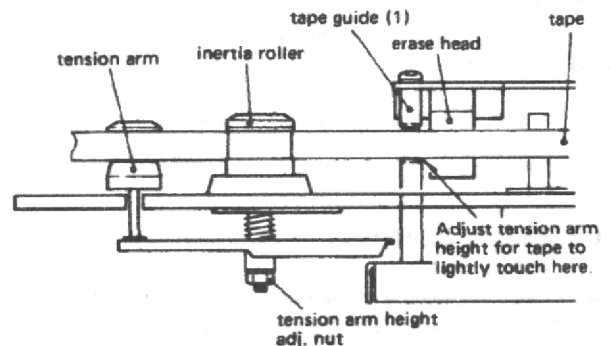

Fig. 2-21 Tension arm height adjustment

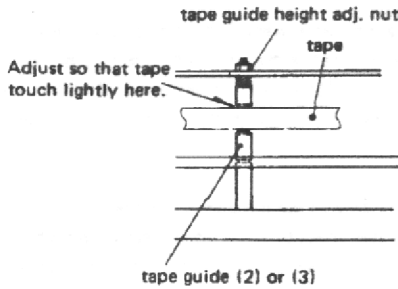

Fig. 2-22 Tape guide height adjustment

2-12-4 FINE ADJUSTMENT OF PINCH ROLLER PARALLELISM

During both forward and reverse with HIGH tape speed, each pinch roller should satisfy the following requirement.

1. Remove pinch roller cap.
2. Manually move pinch roller upward by 1 ~ 2mm from the stop portion of the pinch roller spindle, then play a test tape.
3. During play mode, observe whether the pinch roller position changes in the spindle direction.
4. If a change is found, re-adjust accurately tilt of pinch roller spindle by method illustrated in Fig. 2-18.

2-12-5 HEAD HEIGHT ADJUSTMENT

The following explanation is for the forward play heads. For the reverse play heads, replace bare words by the parentheses-closed words.

1. Confirm that, during forward (reverse) play, the forward (reverse) erase head core protrudes 0.1mm above (below) the moving tape. If not, replace the head with another one and recheck.
2. Fine-adjust each record and playback head height so that the brass-colored spacer of forward (reverse) direction head will show above (below) the moving tape. (About as thick as a thin pencil line).

Fig. shows the forward erase head.

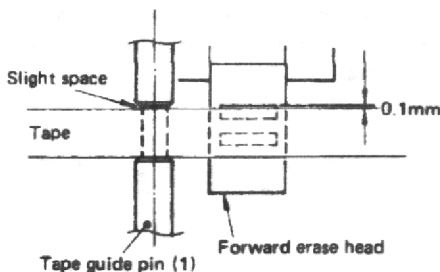

Fig. 2-23 Erase head height

2-13 TAPE SPEED ADJUSTMENT

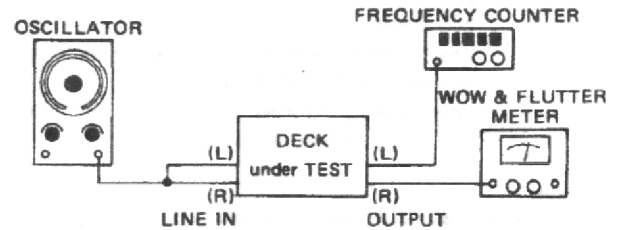

Fig. 2-24

- NOTES:**
1. Conduct all the following in both forward and reverse play modes.
 2. When ordering test tapes, allow for the longer delivery time that is required for them.

1. Connect a frequency counter to either OUTPUT terminal.
2. Load a TEAC YTT-2003 test tape. Set the SPEED switch—HIGH, and PITCH CONT knob—OFF.
3. Play the tape. Adjust HIGH SPEED control (see Fig. 2-25) for a reading of 3,000Hz \pm 5Hz.
4. Check the following at the beginning and the end of the tape.

Specifications:

Tape Speed deviation	3,000Hz \pm 30Hz
Tape speed drift	15Hz
FWD/REV tape speed differential	30Hz

5. Change the test tape to a TEAC YTT-2002, and SPEED switch setting to LOW.
6. Repeat steps 3 through 4. Adjust LOW SPEED control if necessary.
7. Pull the PITCH CONT knob out. Set SPEED switch HIGH. Play a YTT-2003 tape.
8. Check if the speed variation of at least 3,000Hz \pm 180Hz is obtained when the PITCH CONT knob is rotated fully in both directions.
9. Change the test tape to YTT-2002, SPEED switch setting to LOW. Repeat step 8.

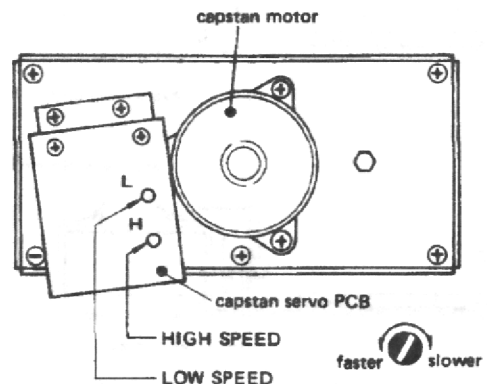

Fig. 2-25

2-14 WOW AND FLUTTER CHECKS

- NOTES:**
1. All the following apply to both forward and reverse play modes.
 2. The following measurements should be made at the beginning and the end of the tape.
 3. When ordering test tapes, allow for the longer delivery time that is required for them.

Playback

1. Connect the test equipment to the deck as shown in Fig. 2-24.
2. Load and play a TEAC YTT-2003 test tape for HIGH speed (19cm/s or 7-½ips), or a TEAC YTT-2002 test tape for LOW speed (9.5cm/s or 3-¾ips).
3. Read the indication on the wow and flutter meter.

Specifications:

HIGH speed:	0.05% WRMS
	0.10% RMS
LOW speed:	0.07% WRMS
	0.12% RMS

Overall

4. Load a TEAC YTT-8013 test tape (blank). Apply and record a 3,000Hz signal.
5. During simultaneous tape monitoring (playing) the recorded signal, read the wow and flutter meter display.

Specifications:

HIGH speed:	0.12% RMS
LOW speed:	0.15% RMS

2-15 REVERSE SOLENOID ADJUSTMENT

1. When the reverse solenoid releases, if the slide plate hits the stopper screw/s noisily, the solenoid stopper plate may be adjusted in the direction of the solenoid housing. See illustration.

Parts below are accessible from the rear of the amplifier chassis.

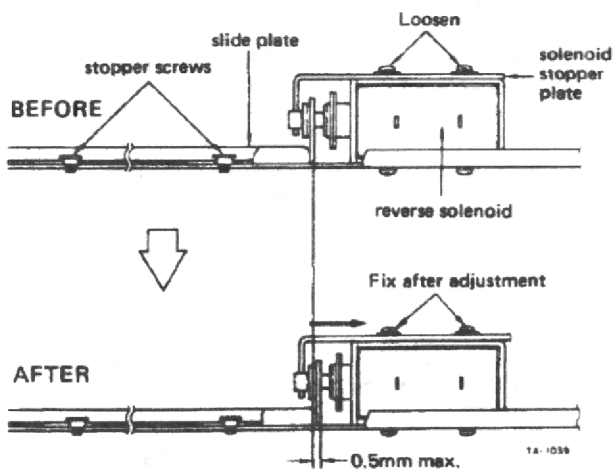

Adjustment range is 0.5mm max. in solenoid-off condition.

Fig. 2-26

2-16 LUBRICATION

Oiling is needed after every 1,000 hours of operation or once a year if the deck is infrequently used. For this purpose, TEAC spindle oil (from TEAC TZ-255 oil kit), Mobil D.T.E. Oil Light, etc. are recommended. Lubrication is normally not necessary except at the points shown.

1. Place the deck in the horizontal position.
2. Apply a few drops of oil to the respective spindles shown, excluding capstans, then spread the oil evenly on the spindle surfaces using a cotton cloth, etc.
3. For capstans, apply a few drops to the indicated position.
4. After oiling all the points, leave the deck for 1 to 2 hours until the oil is thoroughly absorbed.

Figure shows left side. Do also for right side.

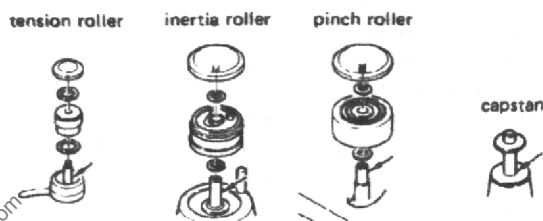

Fig. 2-27

2-17 VOLTAGE CONVERSION (FOR GENERAL EXPORT MODELS)

Always disconnect the power line cord before making these adjustments.

Frequency Conversion

Since the X series uses DC motors, frequency conversion is not necessary.

Voltage Conversion.

1. First remove the two feet by removing the screws in each one.
2. Unscrew the left and right sides of the cabinet.
3. Locate the voltage selector above the power transformer as seen from the rear of the deck.
4. Remove the plug by pulling it out, then re-insert it so that the arrow on the plug is parallel with the white line indicating the proper voltage.
5. Replace the cabinet and feet.

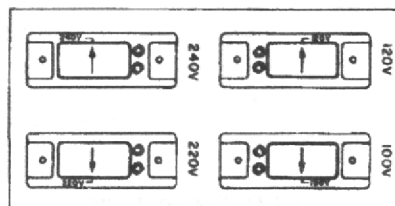

Fig. 2-28

3 ELECTRICAL ADJUSTMENTS AND CHECKS

NOTES:

1. Before performing adjustments and checks, clean and demagnetize the entire tape path.
2. Check that the deck is properly set for the voltage in your locality.
3. In general, adjustments and checks are done in the order of L-ch then R-ch. Double REF. Nos. indicate L-ch/R-ch.

(Example: R371/R372)

4. The value of "dB" refers to 0dB (0.775V). If an AC voltmeter calibrated to 0dB (1V) is to be used, appropriate compensation should be made.
5. The AC voltmeter used in the procedures must have an input impedance of 1M-ohms or more.

3-1 MONITOR PERFORMANCE

ITEM	CONNECTION	MODE/ INSTRUCTION	SIGNAL SOURCE	ADJUST (or CHECK)	RESULT	REMARKS
1. Monitor level	1-1	OSC → ATT to LINE IN (L) AC voltmeter to REC AND PLAY AMPL. PCB term. #14.	DBX sw.—OUT (Leave OUT up to step 25, "DBX PERFORMANCE" section). MONITOR sw.—SOURCE OUTPUT cont.—CAL LINE cont.—MAX MIC cont.—MIN	400Hz/—22dB (61.5mV) R369	—8dB (308mV)	Line min. input level (L)
	1-2	"	"	400Hz/—12dB (195mV) LINE cont. (L/R)	"	LINE spec. input level (L)
	1-3	" but LINE IN (L) → LINE IN (R) #14 → #17	LINE spec. input level condition	"	R370	"
2. Output level	2-1	Fig. 3-1	LINE spec. input level condition	400Hz/—12dB (195mV) R403/R404	—5dB (436mV)	
3. VU meter	3-1	Fig. 3-1	LINE spec. input level condition	400Hz/—12dB (195mV) R371/R372	0VU on VU meter	
4. MIC input level	4-1	Fig. 3-1, but LINE IN → MIC	LINE cont.—MIN MIC cont.—MAX	400Hz/—70dB ±2dB (195μV ~ 308μV) Check	—5dB (436mV)	MIC min. input level
	4-2	"	"	400Hz/—60dB (0.775mV) MIC cont. (L/R)	"	MIC spec. input level
	4-3	Fig. 3-1	LINE cont.—spec. position (item 1-2) MIC cont.—MIN	—	—	IMPORTANT: Do not disturb these cont's during later checks.

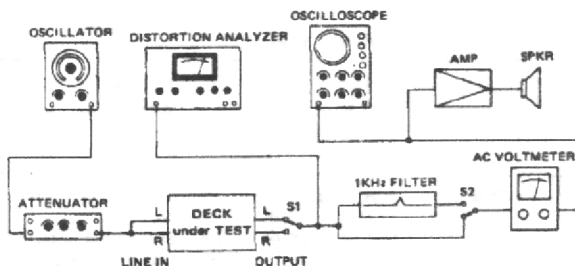

Fig. 3-1 Basic connection

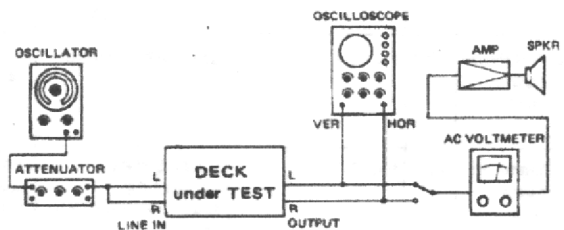

Fig. 3-2 Connection for phase check

TEAC test tapes: For playback alignment
 YTT-1002: For 9.5cm/s or 3-3/4ips, LH II
 YTT-1003: For 19cm/s or 7-1/2ips, LH II
 YTT-1052: For 9.5cm/s or 3-3/4ips, EE
 YTT-1053: For 19cm/s or 7-1/2ips, EE
 For recording alignment (blank)
 YTT-8013: For LH II
 YTT-8063: For EE

3-2 PLAYBACK PERFORMANCE

ITEM	CONNECTION	MODE/ INSTRUCTION	SIGNAL SOURCE	ADJUST (or CHECK)	RESULT	REMARKS
5. Playback head azimuth	5-1 Fig. 3-2	Do for both FWD & REV heads MONITOR sw. — TAPE SPEED sw.—HIGH TAPE SELECT.— LH-II	YTT-1003 (16kHz/-10dB)	Azimuth adj. screw/s of head (Fig. 2-13)	Phase: within 45° on oscilloscope (Fig. 3-3)	
6. Playback level	6-1 Fig. 3-1	FWD & REV OUTPUT cont.— CAL SPEED sw.—HIGH	YTT-1003 (400Hz/0dB)	R313/R314 (FWD) R315/R316 (REV)	-5dB (436mV)	Spec. PB condition
	6-2 "	OUTPUT cont.— MAX.	"	Check	+1dB ±2dB (690mV ~ 1.09V)	Max. output level
	6-3 "	OUTPUT cont.— CAL	"	"	-5dB (436mV)	Spec. PB condition IMPORTANT: Do not disturb OUTPUT cont. during later checks.
7. VU meter	7-1 Fig. 3-1	FWD Spec. PB condition	YTT-1003 (400Hz/0dB)	Check	0VU ±1VU on VU meter	
8. Frequency response	8-1 Fig. 3-1	FWD & REV SPEED— HIGH TAPE SELECT.— LHII	YTT-1003	R327/R328 (FWD) R329/R330 (REV)	Fig. 3-5	
	8-2 "	" SPEED— LOW	YTT-1002	R333/R334 (FWD) R335/R336 (REV)	Fig. 3-6	
	8-3 "	FWD & REV SPEED— HIGH	YTT-1053	Check	Fig. 3-5	
	8-4 "	TAPE SELECT.— EE SPEED— LOW	YTT-1052	"	Fig. 3-6	
9. Phase shift	9-1 Fig. 3-2	FWD & REV SPEED— HIGH	YTT-1003	Check	Phase: within 45° on oscilloscope (50Hz ~ 18kHz) (Fig. 3-3)	
	9-2 "	" SPEED— LOW	YTT-1002	"	" (50Hz ~ 10kHz)	
10. PHONES output level	10-1 Fig. 3-4	Spec. PB condition	YTT-1003 (400Hz/0dB)	Check	-24dB ±2dB (38.8mV ~ 61.5mV) (at PHONES jack)	When OUTPUT terminal is at -5dB
11. Signal to noise ratio	11-1 Fig. 3-1	FWD & REV LH and EE Spec. PB condition Use fully erased tape (Use bulk tape eraser)	YTT-8013 and YTT-8053	Check	LH-I, -II { HIGH: 50dB LOW: 49dB EE { HIGH: 52dB LOW: 52dB	-Ratio of spec. -5dB to noise -Change-over the polarity of the AC Line plug. The worse reading should be within spec.

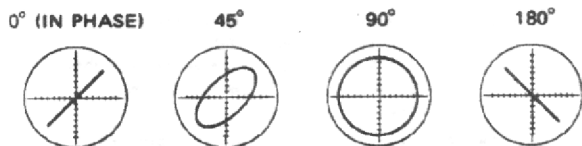

Fig. 3-3 Confirming phase relationship

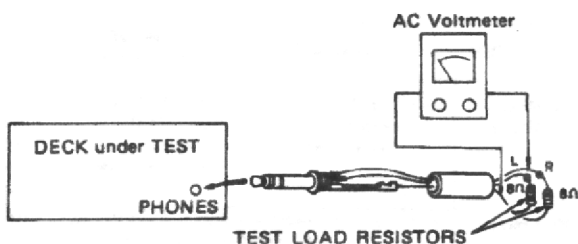

Fig. 3-4 Connection for PHONES level check

3-3 RECORDING PERFORMANCE

TEAC test tape: YTT-8013: For recording alignment (blank) for LHII
 YTT-8053: For recording alignment (blank) for EE

ITEM	CONNECTION	MODE/ INSTRUCTION	SIGNAL SOURCE	ADJUST (or CHECK)	RESULT	REMARKS	
12. Bias trap	12-1	AC voltmeter between BIAS TRAP TP (TP1/TP2) & GND	—	L303/L304	Min. reading	Bias freq.: 100kHz \pm 5kHz	
	12-2	Fig. 3-1	—	Check	Min. reading (-45dB or more (4.36mV or less))		
	12-3	"	"	Check	VU: no deflection		
13. Record head azimuth	13-1	Fig. 3-2	Do for both FWD & REV heads MONITOR sw.—TAPE	10kHz/-32dB (19.5mV)	Azimuth adj. screw/s of head (Fig. 2-13)	Phase: within 45° on oscilloscope (Fig. 3-3)	
14. Record bias	14-1	Fig. 3-1	FWD & REV SPEED sw.—LOW MONITOR sw.—TAPE Test tape—YTT-8053 TAPE SELECTOR—EE	7kHz/-22dB (61.5mV)	R515/R516 (FWD) R517/R518 (REV)	Over-bias value 3dB \pm 1dB (from peak)	-Simultaneous monitoring -First set adjustor fully CCW (↺), then adjust.
	14-2	"	Test tape—YTT-8013 TAPE SELECTOR—LHII	"	R519/R520 (FWD) R521/R522 (REV)	Over-bias value 4dB \pm 1dB (from peak)	
15. Record level	15-1	Fig. 3-1	Same as 14-2 SPEED sw.—HIGH	400Hz/-12dB (195mV)	R429/R430 (FWD) R431/R432 (REV)	-5dB (436mV)	Spec. REC condition
16. Distortion	16-1	Fig. 3-1	Same as 14-1 and 14-2, but SPEED sw.—HIGH	1kHz/-12dB (195mV)	Check	0.8% or less (w/LHII, EE)	
17. Signal to noise ratio	17-1	Fig. 3-1	FWD & REV MONITOR sw.—TAPE HIGH & LOW { LHII { YTT-8013 { EE { YTT-8053	1kHz/-12dB (195mV) then No signal recording	Check	LHII { HIGH: 48dB. { LOW: 46dB EE { HIGH: 50dB { LOW: 50dB	Ratio of spec. -5dB to noise
18. Erase efficiency	18-1	Fig. 3-1 switch on 1kHz filter	FWD & REV TAPE SELECT.—EE MONITOR sw.—TAPE { EE { YTT-8053 SPEED sw.—HIGH	1kHz/-2dB (615mV) (+10VU) then erasing	Check	OUTPUT: -63dB or more (548 μ V or less (68dB min. ratio)	-Reference output level : +5dB -The worst value should be within spec.

ITEM	CONNECTION	MODE/ INSTRUCTION	SIGNAL SOURCE	ADJUST (or CHECK)	RESULT	REMARKS	
19. REC MUTE function	19-1 Fig. 3-1 switch on 1kHz filter	FWD & REV Spec. REC condition rec-mute mode	1kHz/-2dB (615mV) (+10VU) then record muting	Check	OUTPUT: -60dB or more (775μV or less) (65dB min. ratio)	-Reference output level: +5dB -The worst value should be within spec.	
20. Frequency response	20-1 Fig. 3-1	FWD & REV MONITOR sw.- TAPE SELECTOR-EE Test tape- YTT-8053	SPEED sw.- LOW	Requird signal/ -32dB (19.5mV)	L305/L306 (FWD) L307/L308 (REV)	Fig. 3-8	Also it is possible to fine-adjust by the record bias adjustors (see item 14.) if this respective specified record bias setting ranges are kept.
	20-2 "	"	SPEED sw.- HIGH	"	Check	Fig. 3-7	
	20-3 "	TAPE SELECTOR-LHII Test tape- YTT-8013	SPEED sw.- LOW	"	"	Fig. 3-8	
	20-4 "	"	SPEED sw.- HIGH	"	"	Fig. 3-7	
21. Phase shift	21-1 Fig. 3-2	FWD & REV Spec. REC condition SPEED sw.- HIGH	40Hz ~ 16kHz/ -32dB (19.5mV)	Check	Phase: within 45° on oscilloscope (40Hz ~ 16kHz) (Fig. 3-3)		
22. LHI position check	22-1 Fig. 3-1	FWD Spec. REC condition Test tape- YTT-8013 SPEED sw.- HIGH	20kHz/-32dB (19.5mV)	Check	When TAPE SELECTOR sw is changed LHII → LHI, output level should raise +3dB ±1dB		
23. Adjacent track crosstalk	23-1 Fig. 3-1	FWD record. Spec. REC condition SPEED sw.-HIGH TAPE SELECTOR sw.-LHII	125Hz/-12dB (195mV)	-	-	-	For FWD record.
	23-2 "	REV playback the portion recorded above	-	Check	At both L-and R-ch 125Hz: -45dB or more (4.36mV or less) (40dB min. ratio)		
	23-3 "	Interchange R & L reels then do FWD playback	-	"	"	"	
	23-4	Repeat 23-1 through 23-3, but interchange FWD and REV.					For REV record.
24. Channel separation	24-1 Fig. 3-1 switch on 1kHz filter	Same as 23-1	L: 1kHz/-12dB (195mV) R: No signal record.	Check	R, -55dB or or more (1.38mV or less) (50dB min. ratio)	For FWD record.	
	24-2 "	"	L: No signal record. R: 1kHz/-12dB	"	L, "		
	24-3	Repeat 24-1 and 24-2 with REV recording.					For REV record.

3-4 DBX PERFORMANCE

NOTE:

Test this performance only after you are sure that the "3-6 DBX PCB ADJUSTMENT is correct.

ITEM	CONNECTION	MODE/ INSTRUCTION	SIGNAL SOURCE	ADJUST (or CHECK)	RESULT	REMARKS	
25. Encoder level	25-1	OSC → ATT to LINE IN (both L- & R-ch's) AC voltmeter to REC AND PLAY AMPL. PCB term. #46	DBX sw.—OUT MONITOR sw.—SOURCE OUTPUT cont.—CAL LINE cont.—Spec. position (item 1-2) MIC cont.—MIN	1kHz/-12dB (195mV)	Check	-8dB (308mV)	
	25-2	"	Same as above, but DBX sw.—IN	"	R852/R852	-8dB ±0.5dB (291mV ~ 327mV)	
	25-3	Repeat 25-1 ~ 25-2 by changing to REC AND PLAY AMPL. PCB term. #47. IMPORTANT: Do not disturb all MIC, LINE and OUTPUT controls during later checks.					
26. Decoder level	26-1	Fig. 3-1	FWD only Test tape—YTT-8013 DBX sw.—OUT SPEED sw.—HIGH REC MODE—ON TAPE SELECT. sw.—LHII MONITOR sw.—TAPE	1kHz/-12dB (195mV)	Check	Note the measured output as reference.	
	26-2	"	Same as above but DBX sw.—IN	"	R652/R652	±0.5dB deviation from ref.	
27. Frequency response	27-1	Fig. 3-1	Same as 20-1 ~ 20-4, but DBX sw.—IN	Required signal, -32dB (19.5mV)	Check	Figs. 3-9 to 3-10.	
28. Signal to noise ratio	28-1	Fig. 3-1	FWD & REV DBX sw.—IN REC MODE sw.—ON MONITOR sw.—TAPE SPEED sw.—HIGH & LOW { LHII { YTT-8013 { EE { YTT-8053	1kHz/-12dB (195mV) then No signal recording	Check	LHII { HIGH: 65dB { LOW: 65dB EE { HIGH: 65dB { LOW: 65dB	Ratio of spec. -5dB to noise
29. Distortion	29-1	Fig. 3-1	Same as 28-1 but SPEED sw.—HIGH only	1kHz/-12dB (195mV)	Check	0.8% or less (w/LHII, EE)	0VU input level
	29-2	"	"	1kHz/+8dB (1.95V)	"	3% or less (w/LHII, EE)	20VU input level

3-5 FREQUENCY RESPONSE

3-5-1 PLAYBACK

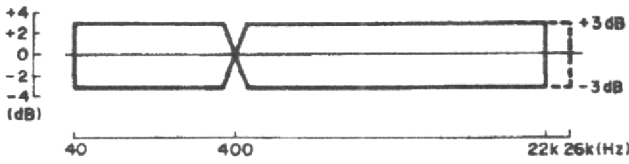

Fig. 3-5 Playback frequency response (19cm/s)

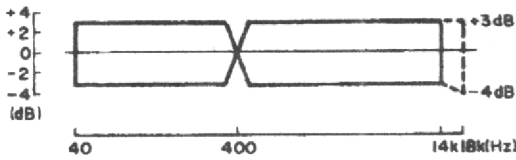

Fig. 3-6 Playback frequency response (9.5cm/s)

3-5-2 OVERALL

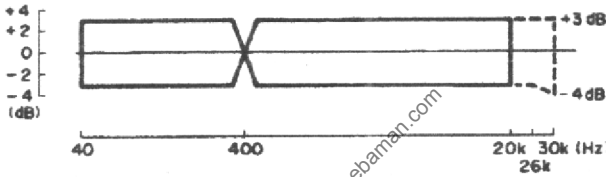

Fig. 3-7 Overall frequency response (19cm/s)

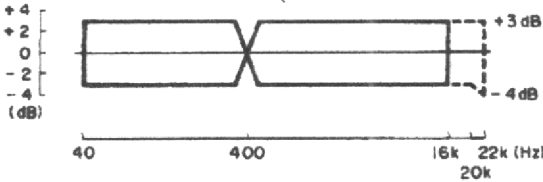

Fig. 3-8 Overall frequency response (9.5cm/s)

3-5-3 OVERALL WITH DBX IN

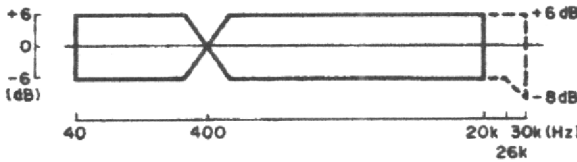

Fig. 3-9 Overall frequency response with DBX IN (19cm/s)

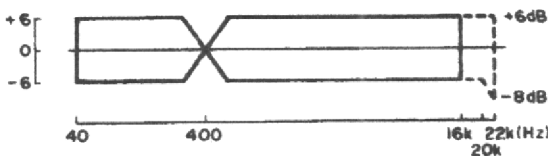

Fig. 3-10 Overall frequency response with DBX IN (9.5cm/s)

3-6 DBX PCB ADJUSTMENT

NOTES:

1. This section adjustment is not usually needed unless an adjustor(s) have been changed or a component(s) on the PC board have sustained damage, since the PC board has been precisely adjusted in the factory.
2. Turn the deck OFF to prevent accidental damage when removing or replacing PC board.

3-6-1 ENCODER ADJUSTMENT

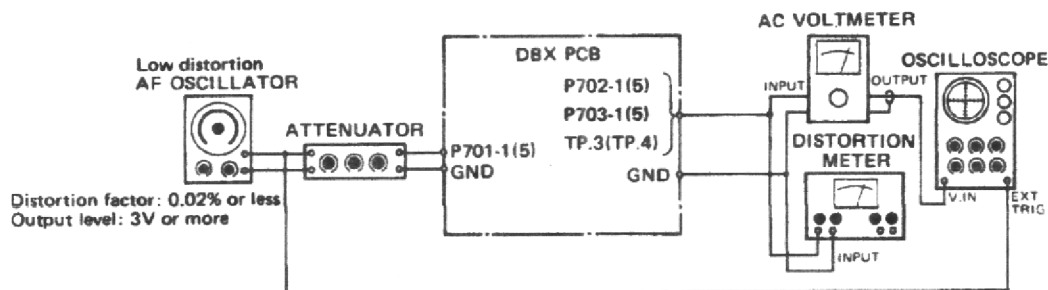

Fig. 3-11 Connection for encoder adjustment

(1) Preparation

1. Disconnect wires (with connector) from connectors P701 ~ P703, then make connections as shown on Fig. 3-11. (Each connector's pin 1 and pin 5 correspond L-ch and R-ch respectively.)
2. Preset R737/R738, R747/R748, R757/R758 and R763/R764 approximately to the center position.

(2) Input setting

3. Apply a 100Hz input signal to P701-1(5), then adjust input level so that output from P702-1(5) becomes 300mV (-8.24dB).

(3) RMS SYM adjustment

4. Adjust R765/R766 so that output waveform at TP3/TP4 becomes a clear 200Hz sine-wave on the oscilloscope.

(4) RMS time constant adjustment

5. Adjust R747/R748 so that output from TP3/TP4 becomes 385 μ V (-66.1dB).

(5) Encoder nominal level adjustment

6. Apply a 1kHz input signal to P701-1(5), then adjust input level so that output from P702-1(5) becomes 300mV (-8.24dB).
7. Adjust R737/R738 so that output from P703-1(5) becomes 300mV (-8.24dB).

(6) VCA SYM adjustment

8. After adjustments above are effected, adjust R757/R758 so that the distortion meter indicates minimum value (0.2% or less).

(7) Frequency response check

9. Check that when input signal is 100Hz, then switched to 10kHz, the output from P703-1(5) becomes 212mV ~ 238mV (-11.3dB ~ -10.3dB), then 165mV ~ 185mV (-13.4dB ~ -12.4dB) respectively.

(8) Encoder effect check - 1

10. Check that when input signal is changed to 1kHz at 300 μ V (-68.2dB) from condition in paragraph (5), output from P703-1(5) becomes 8.95mV ~ 10.1mV (-38.7dB ~ -37.7dB). (In this case, measurement should be done using the 1kHz band-pass filter).

(9) Encoder effect check - 2

11. Check that when input signal is changed to 1kHz at 3V (11.8dB) from condition in paragraph (5), output from P703-1(5) becomes 895mV ~ 1.01V (1.25dB ~ 2.30dB).
12. At this time, the distortion factor should be 0.3% or less.

3-6-2 DECODER ADJUSTMENT

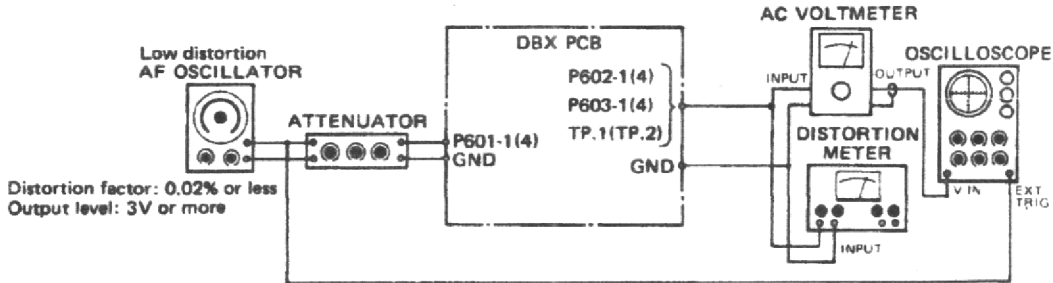

Fig. 3-12 Connection for decoder adjustment

(1) Preparation

1. Disconnect wires (with connector) from connectors P601 ~ P603, then make connections shown on Fig. 3-12. (Each connector's pin 1 and pin 4 correspond L-ch and R-ch respectively.
2. Preset R637/R638, R647/R648, R657/R658 and R663/R664 approximately to the center position.

(2) Input setting

3. Apply a 100Hz input signal to P601-1(4), then adjust input level so that output from P602-1(4) becomes 300mV (-8.24dB).

(3) RMS SYM adjustment

4. Adjust R665/R666 so that output waveform at TP1/TP2 becomes a clear 200Hz sine-wave on the oscilloscope.

(4) RMS time constant adjustment

5. Adjust R647/R648 so that output from TP1/TP2 becomes 385 μ V (-66.1dB).

(5) Decoder nominal level adjustment

6. Apply a 1kHz input signal to P601-1(4), then adjust input level so that output from P602-1(4) becomes 300mV (-8.24dB).

7. Adjust R637/R638 so that output from P603-1(4) becomes 300mV (-8.24dB).

(6) VCA SYM adjustment

8. After the paragraph adjustments above are effected, adjust R657/R658 so that the distortion meter indicates minimum value (0.2% or less).

(7) Frequency response check

9. Check that when input signal is 100Hz, then switched to 10kHz, the output from P603-1(4) becomes 475mV ~ 599mV (-4.25dB ~ -2.24dB), then 789mV ~ 993mV (1.56dB ~ 2.15dB) respectively.

(8) Decoder effect check - 1

10. Check that when input signal is changed to 1kHz at 9.48mV (-38.2dB) from condition in paragraph (5), output from P603-1(4) becomes 267 μ V ~ 336 μ V (-69.3dB ~ -67.3dB). (In this place, measurement should be done using the 1kHz band-pass filter).

(9) Decoder effect check - 2

11. Check that when input signal is changed to 1kHz at 948mV (1.75dB) from condition in paragraph (5), output from P603-1(4) becomes 2.67V ~ 3.37V (10.7dB ~ 12.8dB).

3-7 ADJUSTMENT AND TEST POINT LOCATIONS

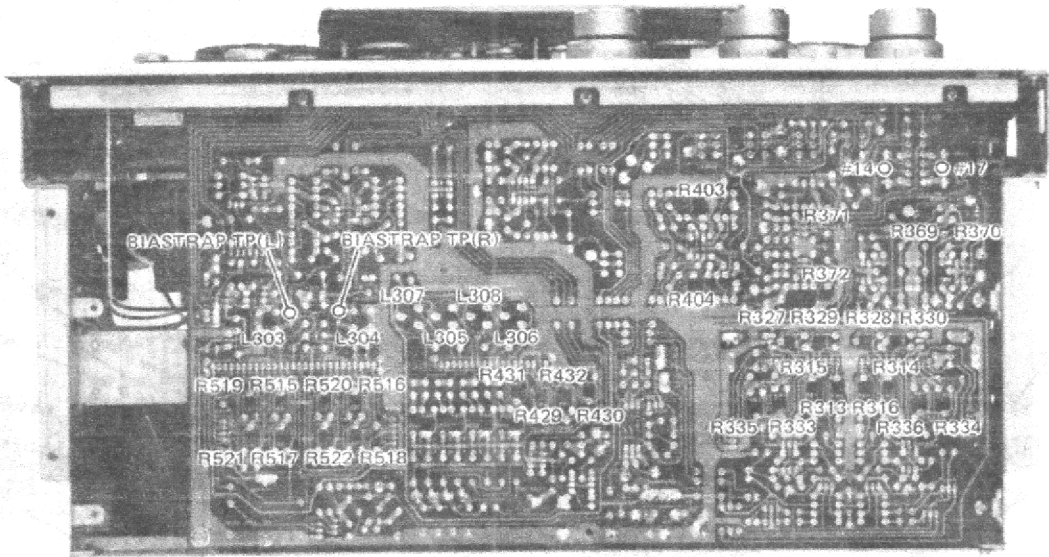

Fig. 3-13 REC AND PLAY AMP PCB

L303/L304	Bias trap (record)
L305/L306	Record EQ (FWD)
L307/L308	Record EQ (REV)
R313/R314	Playback level (FWD)
R315/R316	Playback level (REV)
R327/R328	Playback EQ (HIGH, FWD)
R329/R330	Playback EQ (HIGH, REV)
R333/R334	Playback EQ (LOW, FWD)
R335/R336	Playback EQ (LOW, REV)

R369/R370	Monitor level
R371/R372	VU meter
R403/R404	Output level
R429/R430	Record level (FWD)
R431/R432	Record level (REV)
R515/R516	Record bias for EE (FWD)
R517/R518	Record bias for EE (REV)
R519/R520	Record bias for LH II (FWD)
R521/R522	Record bias for LH II (REV)

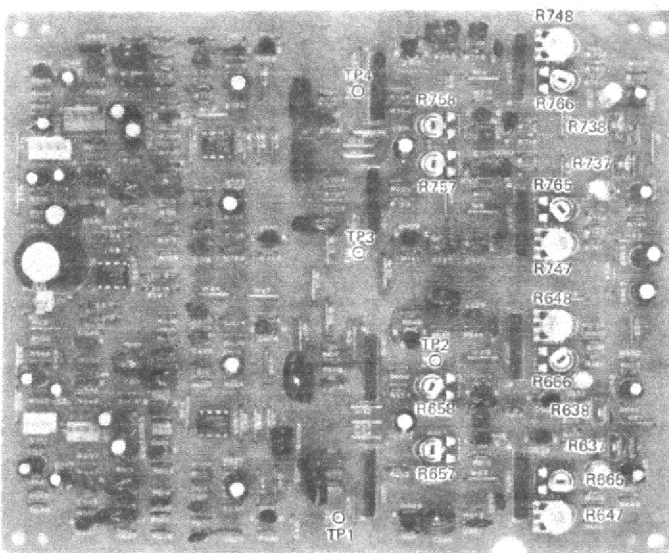
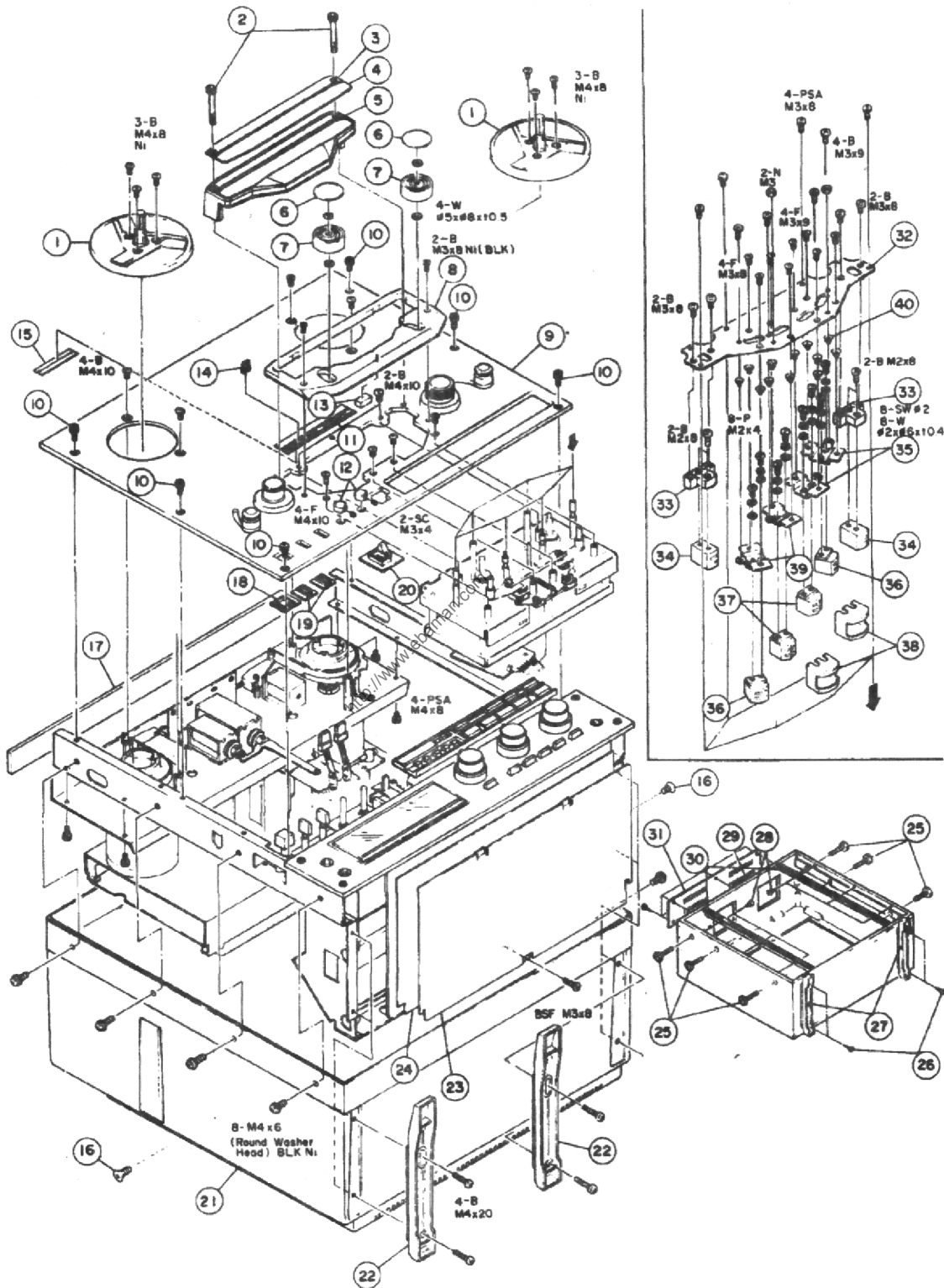

Fig. 3-14 DBX PCB

R637/R638	Nominal level (DECODER)
R647/R648	RMS time constant (DECODER)
R657/R658	VCA SYM (DECODER)
R665/R666	RMS SYM (DECODER)
R737/R738	Nominal level (ENCODER)
R747/R748	RMS time constant (ENCODER)
R757/R758	VCA SYM (ENCODER)
R765/R766	RMS SYM (ENCODER)

4 EXPLODED VIEWS AND PARTS LIST

EXPLODED VIEW-1



Parts marked with * require longer delivery time.

REF. NO.	PARTS NO.	DESCRIPTION	REMARKS
1 - 1	5504744000	Reel Table Assy	X-10R
1 - 2	*5800285000	Screw, Head Housing; X-1000R	
	*5800323400	Screw, Head Housing; X-1000RBL	
1 - 3	*5800283200	Plate, Head Housing; A, X-1000R	
	*5800320601	Plate, Head Housing; A, X-1000RBL	
1 - 4	*5800283300	Plate, Head Housing; B, X-1000R	
	*5800320701	Plate, Head Housing; B, X-1000RBL	
1 - 5	*5800261800	Head Housing	
1 - 6	*5800283900	Cap, Pinch Roller; H, X-1000R	
	*5800320901	Cap, Pinch Roller; X-1000RBL	
1 - 7	*5534691101	Pinch Roller	X-10R
1 - 8	*5800261900	Cover, Head Base Plate	X-10R
1 - 9	*5800269200	Panel, Top, X-1000P	
	*5800320301	Panel, Top, X-1000RBL	
1 - 10	*5581067000	Screw, Top Panel; B, X-1000R	X-10R
	*5581073000	Screw, Top Panel; C, X-1000RBL	32-2B
1 - 11	*5800262400	Escutcheon, Timer	
1 - 12	5800262700	Knob, L; X-1000R	
	5800319601	Knob, L; X-1000RBL	
1 - 13	*5800002700	Cushion, Head Housing	
1 - 14	5800262500	Knob, VR; X-1000R	
	5800319600	Knob, VR; X-1000RBL	
1 - 15	*5800315900	Mask	
1 - 16	*5780204010	Screw, F; M4X10, X-1000R [L]	
	*5780204010	Screw, F; M4X10, X-1000RBL	
1 - 17	*5555887001	Cushion, Case	X-10R
1 - 18	*5800268900	Escutcheon, Power Switch	
1 - 19	*5800268800	Escutcheon, Button	
1 - 20	*5800269100	Escutcheon, Cue; X-1000R	
	*5534708000	Escutcheon, Cue; X-1000RBL	
1 - 21	*5800002802	Case Assy, Deck; L	X-10R
1 - 22	*5533190000	Foot, X-1000R	X-10R
1 - 23	*5553306000	Plate, Ampl. Shield	X-7
1 - 24	*5553308001	Paper, Ampl. Insulating	X-10R
1 - 25	*5504499000	Screw Assy, Case; X-1000R [L]	A-480
	*5504499000	Screw Assy, Case; X-1000RBL	A-480
1 - 26	*5781603116	Screw, M3.1x16; X-1000R [L]	
	*5781603116	Screw, M3.1x16; X-1000RBL	
1 - 27	*5504493100	Foot Assy, X-1000R [L]	A-6600
	*5504493100	Foot Assy, X-1000RBL	A-6600
1 - 28	*5781613110	Screw, M3x10; X-1000R [L]	
	*5781613110	Screw, M3x10; X-1000RBL	
1 - 29	*5800321701	Case, X-1000R [L]	
	*5800321701	Case, X-1000RBL	
1 - 30	*5800321800	Sush, X-1000R [L]	
	*5800321800	Sush, X-1000RBL	
1 - 31	*5800349600	Ventilator	
1 - 32	*5553289100	Plate, Head Base	X-10R
1 - 33	*5800285300	Spacer, Head; E	
1 - 34	5378300800	Head, Erase	X-20R
1 - 35	*5555673000	Bracket, Head; R	X-10R
1 - 36	5378300600	Head, Record	X-20R
1 - 37	5378300700	Head, Playback	X-20R
1 - 38	*5554949000	Head Shield, B	A-6600
1 - 39	*5556672000	Bracket, Head; L	X-10R
1 - 40	*5520182000	Spring; D	A-5300

[U] : U.S.A. [C] : CANADA [GE] : GENERAL EXPORT
 [A] : AUSTRALIA [E] : EUROPE [UK] : U.K.
 [L] : LIMITED AREA

EXPLODED VIEW-2

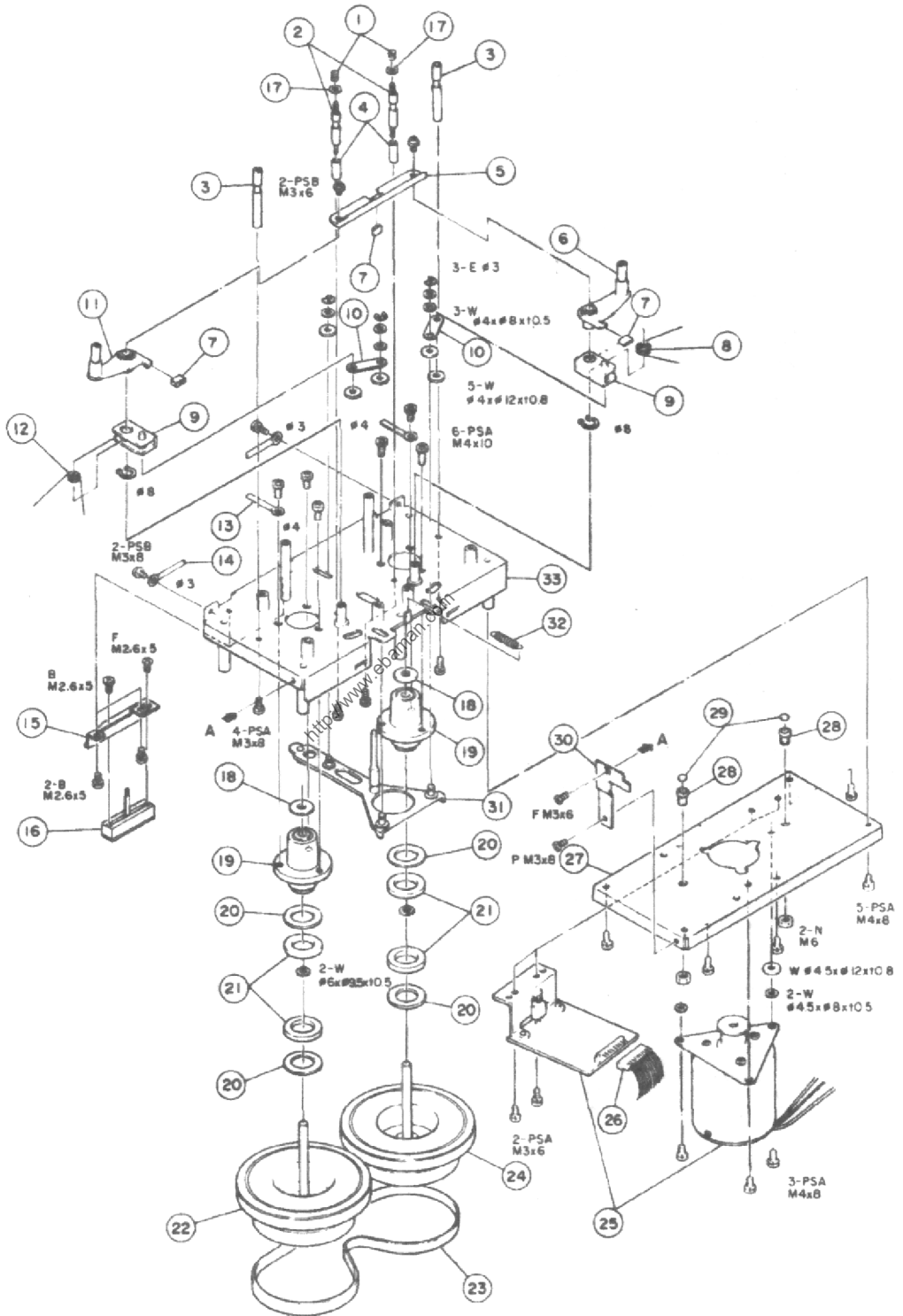

Parts marked with * require longer delivery time.

REF. NO.	PARTS NO.	DESCRIPTION	REMARKS
2 - 1	*5800285600	Spring, Guide	
2 - 2	*5800285400	Tape Guide	X-10R
2 - 3	*5545023000	Pin, Tape Guide	
2 - 4	*5800285500	Support, Guide	
2 - 5	*5555666000	Plate, Joint	X-10R
2 - 6	*5504729000	Arm Assy, Pinch Roller; R	X-10R
2 - 7	*5534694000	Cushion, Stopper	X-10R
2 - 8	*5524216000	Spring, Pinch Roller; R	X-10R
2 - 9	*5504731000	Bracket Assy, Pinch Roller Arm	X-10R
2 - 10	*55556667000	Plate, Joint	X-10R
2 - 11	*5504730000	Arm Assy, Pinch Roller; L	X-10R
2 - 12	*5524217000	Spring, Pinch Roller; L	X-10R
2 - 13	*5786714000	Clamper, Cord, φ4	
2 - 14	*5786713000	Clamper, Cord, φ3	
2 - 15	*5800270201	Bracket, VR	
2 - 16	5284005500	Slide VR, 100KΩ(B)	
2 - 17	*5800286100	Washer	
2 - 18	*5534695000	Washer, Oil Retaining	X-10R
2 - 19	5504726100	Housing Assy, Capstan Flywheel	X-10R
2 - 20	*5555704000	Tape, Adhesive	X-10R
2 - 21	*5534715000	Ring, Magnet; Thrust	X-10R
2 - 22	5504728000	Flywheel Assy, Capstan; L	X-10R
2 - 23	5534692000	Belt, Capstan Drive	X-10R
2 - 24	5504727000	Flywheel Assy, Capstan; R	X-10R
2 - 25	7105018001	DC Motor Assy, Capstan	X-7R
2 - 26	*5122172000	Connector Socket, 10P (WHT)	
2 - 27	*5800138000	Plate, Bearing	X-20R
2 - 28	*5544003000	Screw, Bearing	A-7300
2 - 29	*5555703000	Bearing	X-10R
2 - 30	*5555914100	Plate, Bearing	X-10R
2 - 31	*5504733001	Plate Assy, Slide	X-10R
2 - 32	*5524219000	Spring, Slide Plate	X-10R
2 - 33	*5503196000	Chassis Assy, Capstan	X-10R

INCLUDED ACCESSORIES

REF. NO.	PARTS NO.	DESCRIPTION	REMARKS
	5350008500	Cord, Input-Output Connection	
	5062962000	Splicing Tape	
	5027288000	Sensing Foil	
	5598054001	Reel Adapter, Clamp (TZ-612A)	
	5101337100	Open Reel Supplement [U]	
	5101708000	Open Reel Supplement [All except U]	
	5700030700	X-1000R, X-1000RBL Owners Manual [U]	
	5700030800	X-1000R, X-1000RBL Owners Manual [All except U]	

[U] : U.S.A.
[A] : AUSTRALIA
[L] : LIMITED AREA

[C] : CANADA
[E] : EUROPE

[GE] : GENERAL EXPORT
[UK] : U.K.

EXPLODED VIEW-3

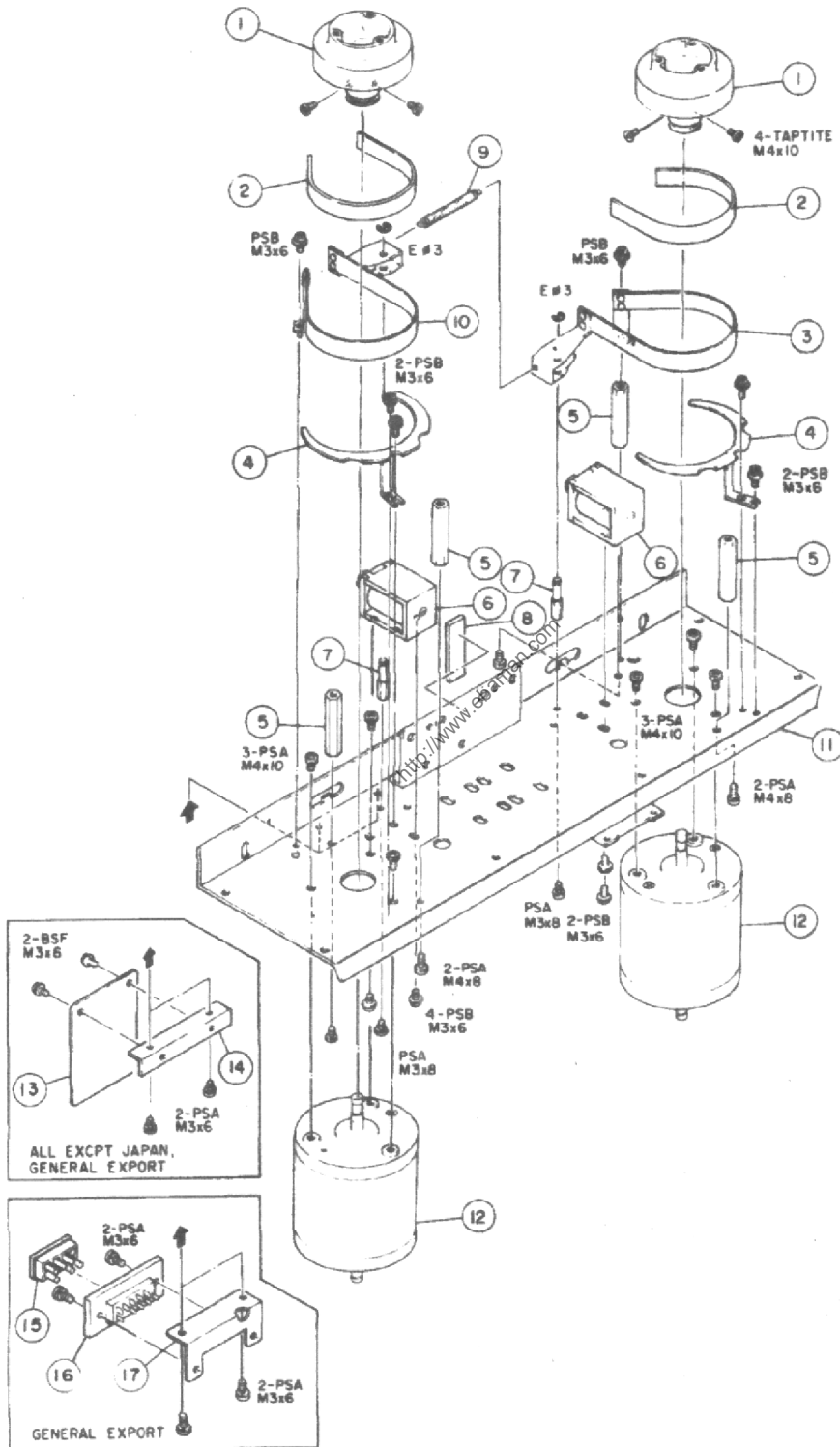

Parts marked with * require longer delivery time.

REF. NO.	PARTS NO.	DESCRIPTION	REMARKS
3 - 1	*5800328200	Base Assy, Reel Table	
3 - 2	*5555274000	Shoe, Brake	A-3300SX
3 - 3	5504736000	Band Assy, Brake; R	X-10R
3 - 4	*5555685000	Plate, Band Assy Retaining	X-10R
3 - 5	*5544916000	Stay, Top Panel; A	A-6100MK11
3 - 6	5183044000	Solenoid, Brake	
3 - 7	*5545033000	Shaft, Brake Band	X-10R
3 - 8	*5555570000	Cushion	1-500
3 - 9	*5524294000	Spring, Brake	X-10R
3 - 10	5504736000	Band Assy, Brake; L	X-10R
3 - 11	*5503194002	Chassis Assy, Reel Motor	X-10R
3 - 12	7106018001	DC Motor, Reel	X-7
3 - 13	*5168997000	PCB Assy, FUSE [U, C]	
	*5158105000	PCB Assy, FUSE [E, A, UK]	
3 - 14	*5556789000	Bracket, FUSE PCB Assy [All except GE, L]	
3 - 15	Δ*5133014000	Plug [GE, L]	
3 - 16	Δ*5133015000	Socket [GE, L]	
3 - 17	*5800361800	Bracket, Switch [GE, L]	

<http://www.ebaman.com>

(Continued from page 29)

REF. NO.	PARTS NO.	DESCRIPTION	REMARKS
5 - 48	*5200072300	PCB Assy, PITCH CONT	
5 - 49	*5534713000	Rod, C	X-10R
5 - 50	*5552392001	Chassis, Control	X-10R
5 - 51	5800271000	Button Assy, Control; X-1000R	
	*5800320500	Button Assy, Control; X-1000RBL	
5 - 52	*5800348001	Tension Roller Assy (A)	
5 - 53	*5783083012	Screw, M3X12	
5 - 54	*5800348500	Collar	

[U]: U.S.A. [C]: CANADA [GE]: GENERAL EXPORT
 [A]: AUSTRALIA [E]: EUROPE [UK]: U.K.
 [L]: LIMITED AREA

EXPLODED VIEW-4

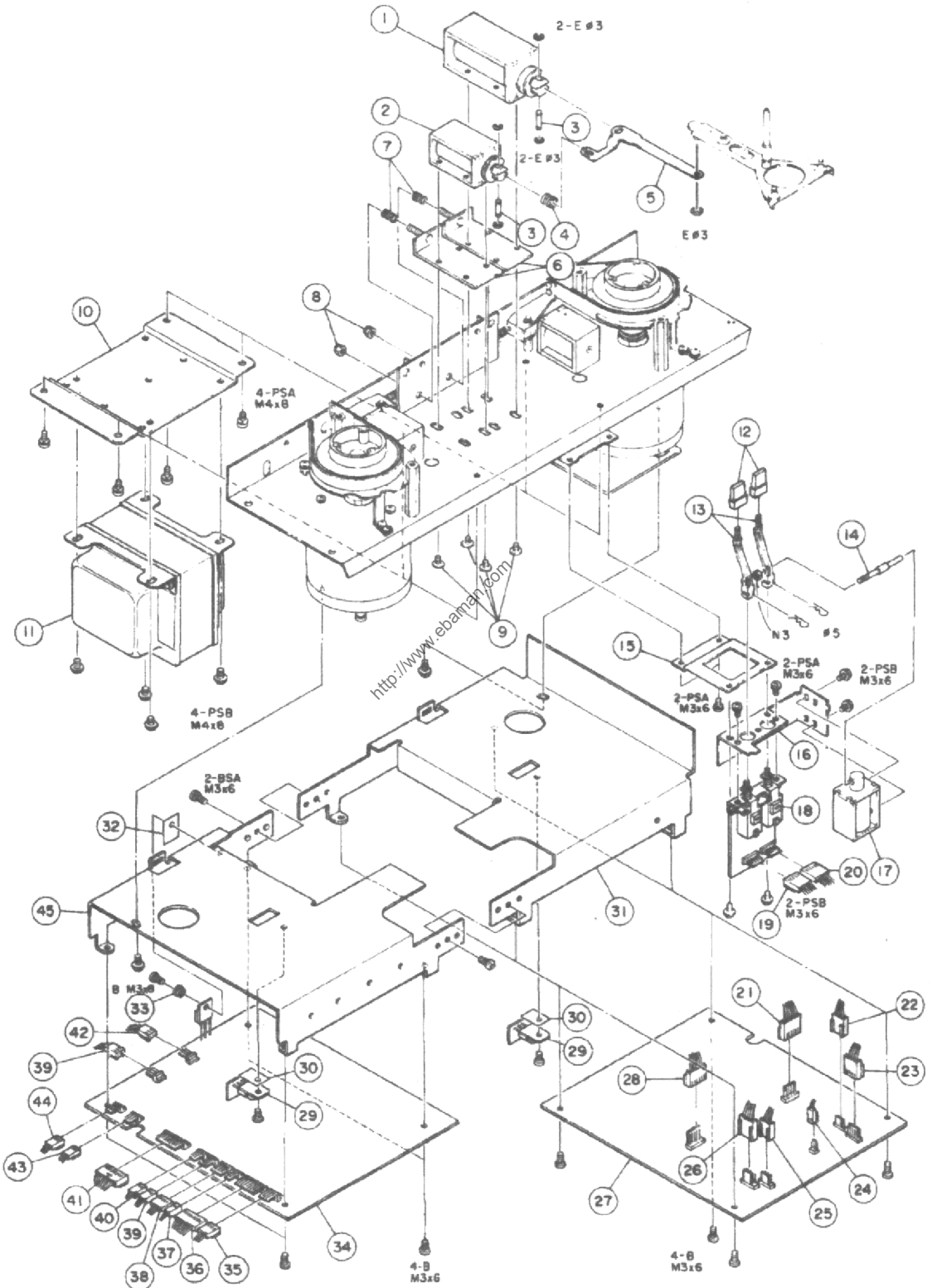

Parts marked with * require longer delivery time.

REF. NO.	PARTS NO.	DESCRIPTION	REMARKS
4 - 1	5163041001	Solenoid, Pinc Roller	
4 - 2	5163042000	Solenoid, Pause	
4 - 3	*5545022000	Pin, Solenoid	X-10R
4 - 4	*5524071000	Spring, Solenoid	AL-700
4 - 5	*5555668000	Plate; C	X-10R
4 - 6	*5504732000	Plate Assy, Solenoid	X-10R
4 - 7	*5524218000	Spring, Pinch Roller Pressure	X-10R
4 - 8	*5581066000	Nut, Nylon; M4	
4 - 9	*5800022600	Screw, Shoulder; G	X-10R
4 - 10	*5655681100	Bracket, Power Transformer	X-10R
4 - 11	Δ*5320014200	Transformer, Power [U, C]	
	Δ*5320014300	Transformer, Power [GE, L]	
	Δ*5320014400	Transformer, Power [E, UK, A]	
4 - 12	*5800262600	Button; Timer; X-1000R	
	*5800319500	Button, Timer; X-1000RBL	
4 - 13	*5534685000	Rod, Switch	X-10R
4 - 14	*5545024001	Shaft, Timer Solenoid	X-10R
4 - 15	*5555664000	Plate, Joint	X-10R
4 - 16	*5555671100	Bracket, Timer Switch	X-10R
4 - 17	5163045000	Solenoid, Timer	
4 - 18	*5200067300	PCB Assy, TIMER	
4 - 19	*5122166000	Connector Socket, 4P (WHT)	
4 - 20	*5122167000	Connector Socket, 5P (WHT)	
4 - 21	*5122223000	Connector Socket, 4P (BLK)	
4 - 22	*5122282000	Connector Socket, 4P (RED)	
4 - 23	*5122166000	Connector Socket, 4P (WHT)	
4 - 24	*5122164000	Connector Socket, 2P (WHT)	
4 - 25	*5122167000	Connector Socket, 5P (WHT)	
4 - 26	*5122283000	Connector Socket, 5P (RED)	
4 - 27	*5200067600	PCB Assy, DBX [All except U, C]	
	*5200067610	PCB Assy, DBX [U, C]	
4 - 28	*5122224000	Connector Socket, 5P (BLK)	
4 - 29	*5200073100	PCB Assy, TRANSISTOR	
4 - 30	*5800328700	PLate, Insulating	
4 - 31	*5800269701	Bracket, PCB; Ampl	
4 - 32	*5033291000	Plate, Insulating	
4 - 33	*5033295000	Tube, Insulating	
4 - 34	*5200067700	PCB Assy, POWER/SERVO	
4 - 35	*5122282000	Connector Socket, 4P (RED)	
4 - 36	*5122170000	Connector Socket, 8P (WHT)	
4 - 37	*5122164000	Connector Socket, 2P (WHT)	
4 - 38	*5122167000	Connector Socket, 5P (WHT)	
4 - 39	*5122281000	Connector Socket, 3P (RED)	
4 - 40	*5122166000	Connector Socket, 4P (WHT)	
4 - 41	*5122227000	Connector Socket, 8P (BLK)	
4 - 42	*5122223000	Connector Socket, 4P (BLK)	
4 - 43	*5122165000	Connector Socket, 3P (WHT)	
4 - 44	*5122222000	Connector Socket, 3P (BLK)	
4 - 45	*5900269601	Bracket, PCB, SERVO	

<http://www.ebaman.com>

[U]: U.S.A. [C]: CANADA [GE]: GENERAL EXPORT
 [A]: AUSTRALIA [E]: EUROPE [UK]: U.K.
 [L]: LIMITED AREA

EXPLODED VIEW-5

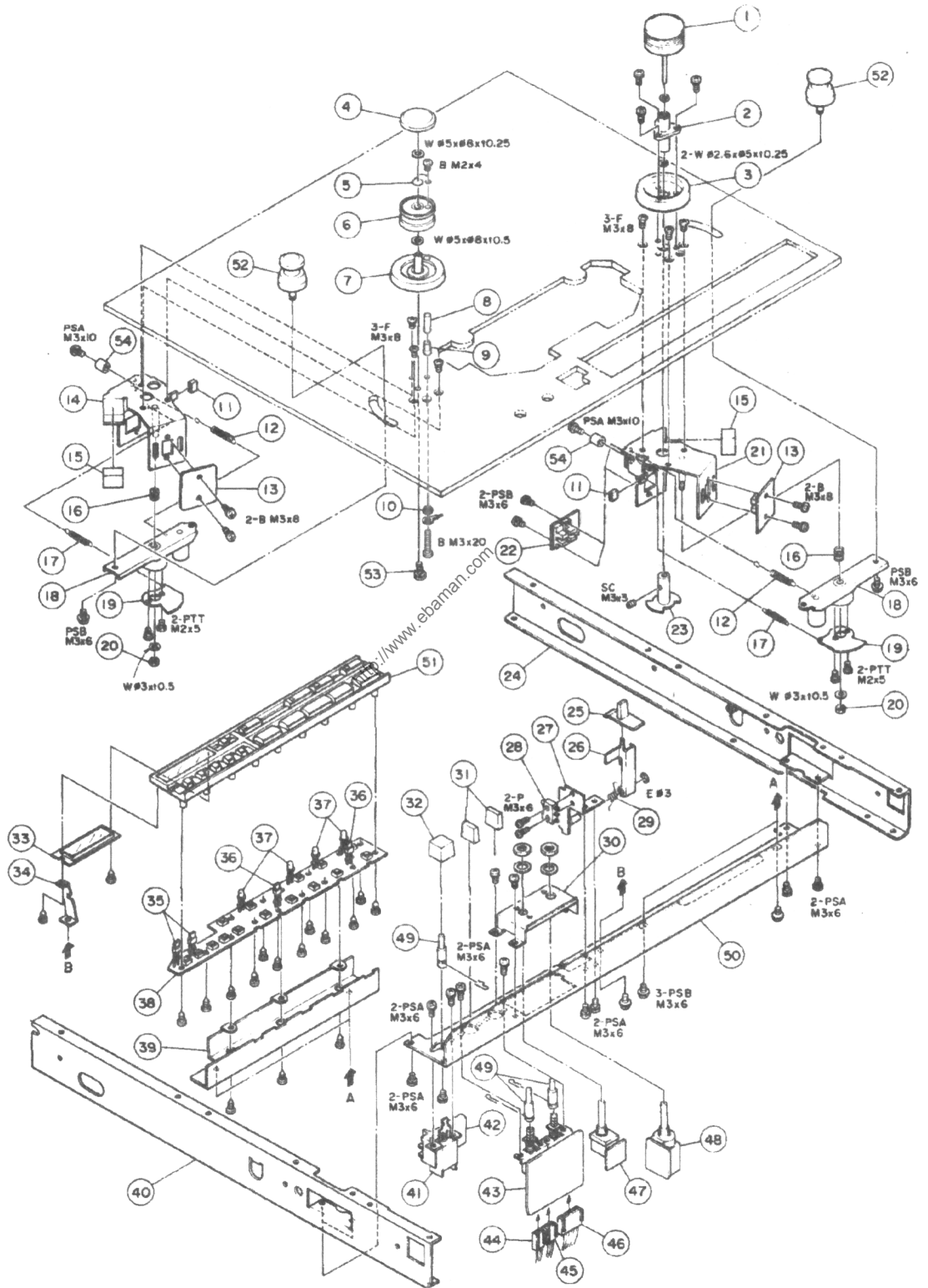

Parts marked with * requires longer delivery time.

REF. NO.	PARTS NO.	DESCRIPTION	REMARKS
5 - 1	5800270500	Roller Assy, X-1000R	
	5800321300	Roller Assy, X-1000RBL	
5 - 2	*5504516000	Metal Holder Assy	
5 - 3	*5800270400	Base, Roller; X-1000R	
	*5800215000	Base, Roller; X-1000RBL	
5 - 4	*5800283700	Cap, Roller; H, X-1000R	
	*5800321000	Cap, Roller; X-1000RBL	
5 - 5	*5524225000	Spring, GND	X-10R
5 - 6	5504740002	Roller Assy, A	X-10R
5 - 7	*5504739000	Base Assy, Roller; A, X-1000R	X-10R
	*5800323100	Base Assy, Roller; B, X-1000RBL	
5 - 8	*5545042000	Post, Sensing	X-10R
5 - 9	*5534718000	Post, Insulating	X-10R
5 - 10	*5534368100	Washer, Insulating	A-6600
5 - 11	*5027699000	Collar, Rubber	
5 - 12	*5800270900	Spring, Tension	
5 - 13	*5200067402	PCB Assy, Tension Sensor	
5 - 14	*5800269801	Base Assy, Shut off; L	
5 - 15	*5534686000	Cushion	X-10R
5 - 16	*5524069000	Spring, Roller Arm	AL-700
5 - 17	*5800270801	Spring, Return	
5 - 18	5800271601	Arm Assy, Tension	
5 - 19	*5800270700	Shautter	
5 - 20	*5581045000	Nut, Nylon	
5 - 21	*5800269901	Base Assy, Shut off; R	
5 - 22	*5200067201	PCB Assy, Roller Sensor	
5 - 23	*5800271301	Plate Assy	
5 - 24	*5552393102	Angle, Side; R	X-10R
5 - 25	*5800263000	Knob, Cue; X-1000R	
	*5800319900	Knob, Cue; X-1000RBL	
5 - 26	*5555697000	Lever, Cue	X-10R
5 - 27	*5504737000	Bracket Assy, Cue	X-10R
5 - 28	*5301455500	Switch, Miclo; SS5GL13-F	
5 - 29	*5524223001	Spring, Cue	X-10R
5 - 30	*5555699000	Bracket, Speed Switch	X-10R
5 - 31	5800263100	Button, Switch; X-1000R	
	5800320000	Button, Switch; X-1000RBL	
5 - 32	5800268600	Button, Power Switch; X-1000R	
	5800320100	Button, Power Switch; X-1000RBL	
5 - 33	5225009600	Indicator, LED	
5 - 34	*5800283500	Plate, Reinforcement	
5 - 35	5225005900	LED (RED)	
5 - 36	5225006800	LED (GREEN)	
5 - 37	5225010500	LED (RED)	
5 - 38	*5200067001	PCB Assy, Keyboard	
5 - 39	*5800271200	Bracket, Button; Control	
5 - 40	*5552394101	Angle, Side; L	X-10R
5 - 41	△ 5134036000	Switch, Power [GE, L]	
	△ 5134037000	Switch, Power [U]	
	△ 5134018000	Switch, Power [C]	
	△ 5134011000	Switth, Power [E, UK, A]	
5 - 42	△ *5052907000	Spark Killer, 0.01μF +300/300V [GE, L]	
	△ *5052910000	Spark Killer, 0.033μF +120/125V [U]	
	△ *5052911000	Spark Killer, 0.033μF +120/250V [C]	
	△ *5267702500	Spark Killer, 0.0047μF 250V [E, UK, A]	
5 - 43	*5200067100	PCB Assy, SPEED SW	
5 - 44	*5122185000	Connector Socket, 3P (WET)	
5 - 45	*5122240000	Connector Socket, 3P (RED)	
5 - 46	*5122188000	Connector Socket, 6P (WET)	
5 - 47	*5200067500	PCB Assy, AUTO REVERSE	

(Continued on page 25)

[U]: U.S.A.
[A]: AUSTRALIA
[L]: LIMITED AREA

[C]: CANADA
[E]: EUROPE

[GE]: GENERAL EXPORT
[UK]: U.K.

EXPLODED VIEW-6

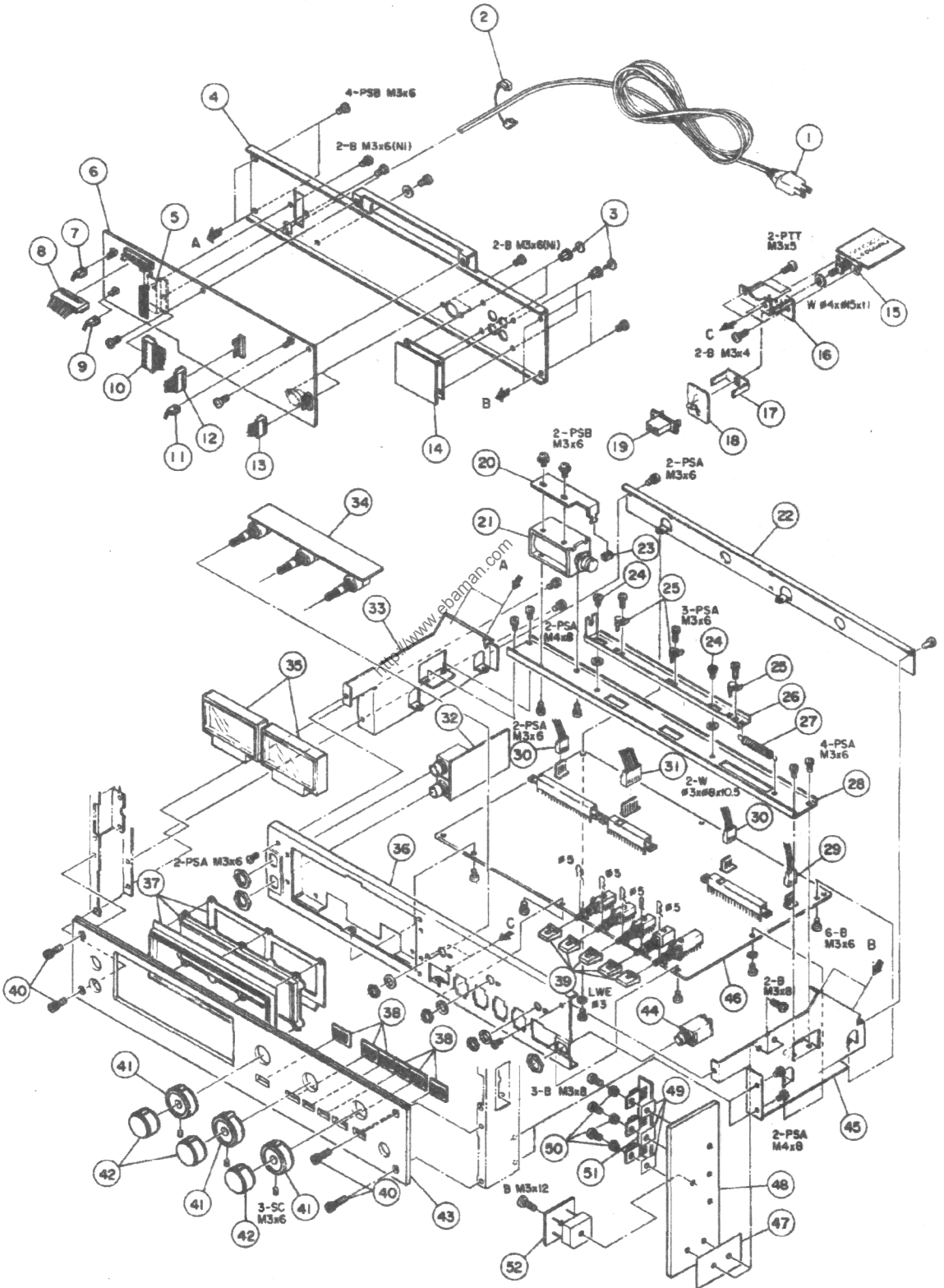

REF. NO.	PARTS NO.	DESCRIPTION	REMARKS
6 - 1	△*5128065000 △*5350008200 △*5350008300 △*5128047000	Cord, AC Power [U, C, GE, L] Cord, AC Power [E] Cord, AC Power [A] Cord, AC Power [UK]	
6 - 2	*5534660000 *5534661000	Strain Relief, AC Power Cord [All except UK] Strain Relief, AC Power Cord [UK]	
6 - 3	*5534118000	Push Rivet	
6 - 4	*5800270300	Panel, Ampl.; Rear; H	
6 - 5	*5800283400	Bracket, Connector	
6 - 6	*5200066900	PCB Assy, CONTROL	
6 - 7	*5122164000	Connector Socket, 2P (WHT)	
6 - 8	*5122176000	Connector Socket, 14P (WHT)	
6 - 9	*5122221000	Connector Socket, 2P (BLK)	
6 - 10	*5122177000	Connector Socket, 15P (WHT)	
6 - 11	*5122280000	Connector Socket, 2P (RED)	
6 - 12	*5122172000	Connector Socket, 10P (WHT)	
6 - 13	*5122168000	Connector Socket, 6P (WHT)	
6 - 14	*5200036000	PCB Assy, IN/OUTPUT	
6 - 15	*5200072400	PCB Assy, DBX SW	
6 - 16	*5800140401	Bracket, Push SW; F	X-20R
6 - 17	*5800140500	Button, Holder; F	X-20R
6 - 18	*5200072500	PCB Assy, LED	
6 - 19	5800283600 5800320800	Button, DBX; H, X-1000R Button, DBX; X-1000RBL	
6 - 20	*5555701000	Plate, Solenoid Stopper	X-10R
6 - 21	5163043000	Solenoid, Reverse	
6 - 22	*5553297100	Bracket, REC AND PLAY AMPL PCB	X-10R
6 - 23	*5534116000	Cushion	A-400
6 - 24	*55B1056000	Screw, Shoulder	A-304
6 - 25	*5524224000	Spring, Plate; Change	X-10R
6 - 26	*5555694000	Plate, Slide	X-10R
6 - 27	*5524222000	Spring, Return	X-10R
6 - 28	*5553298000	Bracket, Solenoid	X-10R
6 - 29	*5122282000	Connector Socket, 4P (RED)	
6 - 30	*5122166000	Connector Socket, 4P (WHT)	
6 - 31	*5122170000	Connector Socket, 8P (WHT)	
6 - 32	*5200046500	PCB Assy, MIC AMP	
6 - 33	*5553294100	Frame, Ampl.; A, L	
6 - 34	*5200035900	PCB Assy, VR	X-20R
6 - 35	5296004900 5296005100	Meter, VU; X-1000R Meter, VU; X-1000RBL	
6 - 36	*5800246701	Cahsis Assy, Ampl.	X-20R
6 - 37	*5800262000	Escutcheon Assy, Meter; X-1000R	
6 - 38	*5800319200 *5800269000	Escutcheon Assy, Meter; X-1000RBL Escutcheon, Button; H	
6 - 39	5800266700 5800320200	Button, H; X-1000R Button, X-1000RBL	
6 - 40	*5581067000	Screw, Ampl. Panel; B	
6 - 41	5800262900 5800319801	Knob, VR; N, X-1000R Knob, VR; N, X-1000RBL	
6 - 42	5800262800 5800319701	Knob, VR; M, X-1000R Knob, VR; M, X-1000RBL	
6 - 43	*5800269300 *5800320401	Panel, Ampl.; H, X-1000R Panel, Ampl.; I, X-1000RBL	
6 - 44	*5124026000	Jack, PHONES	
6 - 45	*5553295102	Frame, Ampl.; A, R	X-10R
6 - 46	*5200072600 *5200072610	PCB Assy, REC AND PLAY AMPL [All except U, C] PCB Assy, REC AND PLAY AMPL [U, C]	
6 - 47	*5800328700	Plate, Insulating	
6 - 48	*5800296601	Heat Sink	
6 - 49	*5033291000	Plate, Insulating	
6 - 50	*5033295000	Tube, Insulating	
6 - 51	5200079100	PCB Assy, TRANSISTOR; B	
6 - 52	5200079000	PCB Assy, DIODE	

[U]: U.S.A.

[C]: CANADA

[GE]: GENERAL EXPORT

[A]: AUSTRALIA

[E]: EUROPE

[UK]: U.K.

[L]: LIMITED AREA

REC AND PLAY AMPL PCB 115

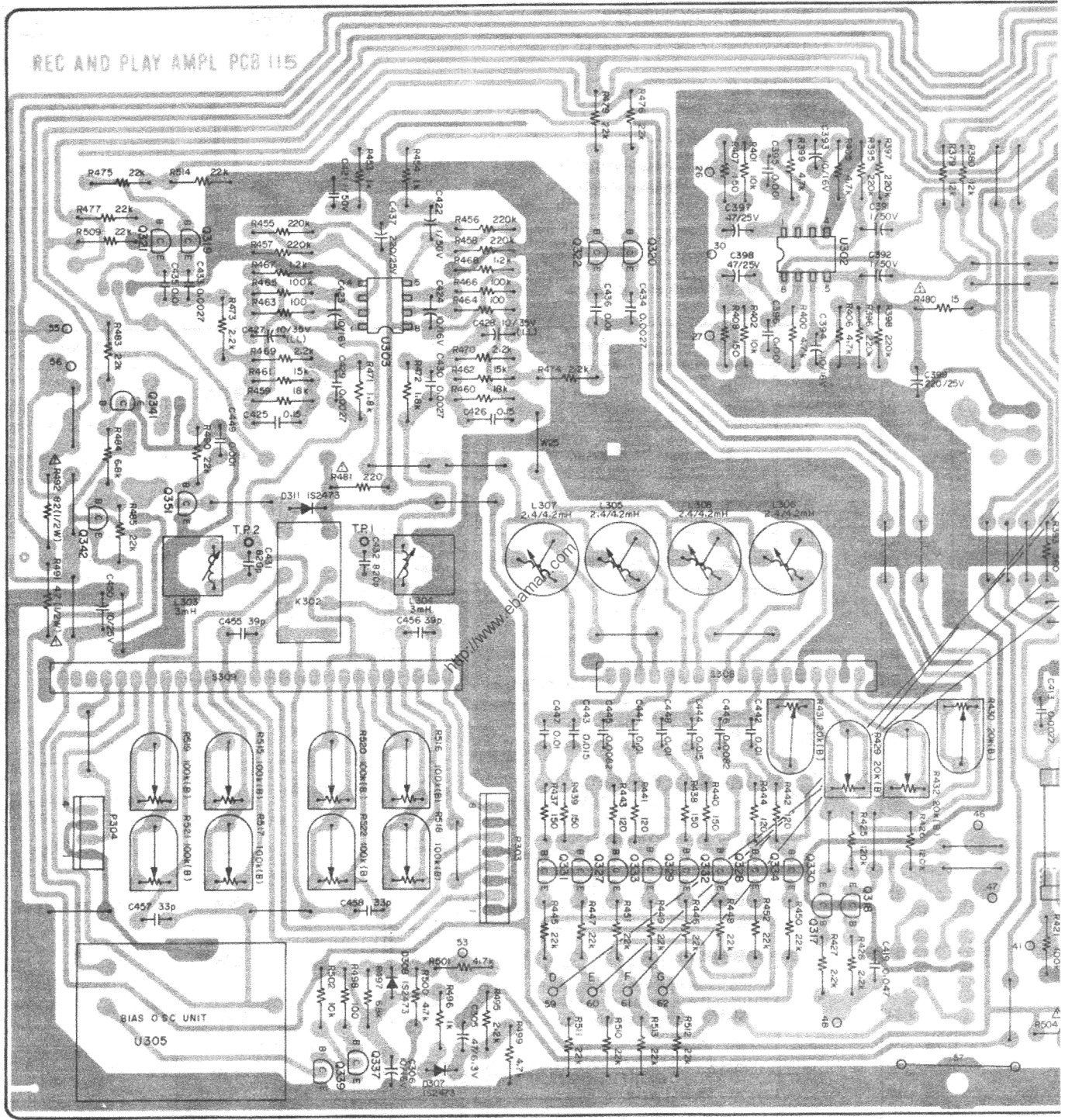

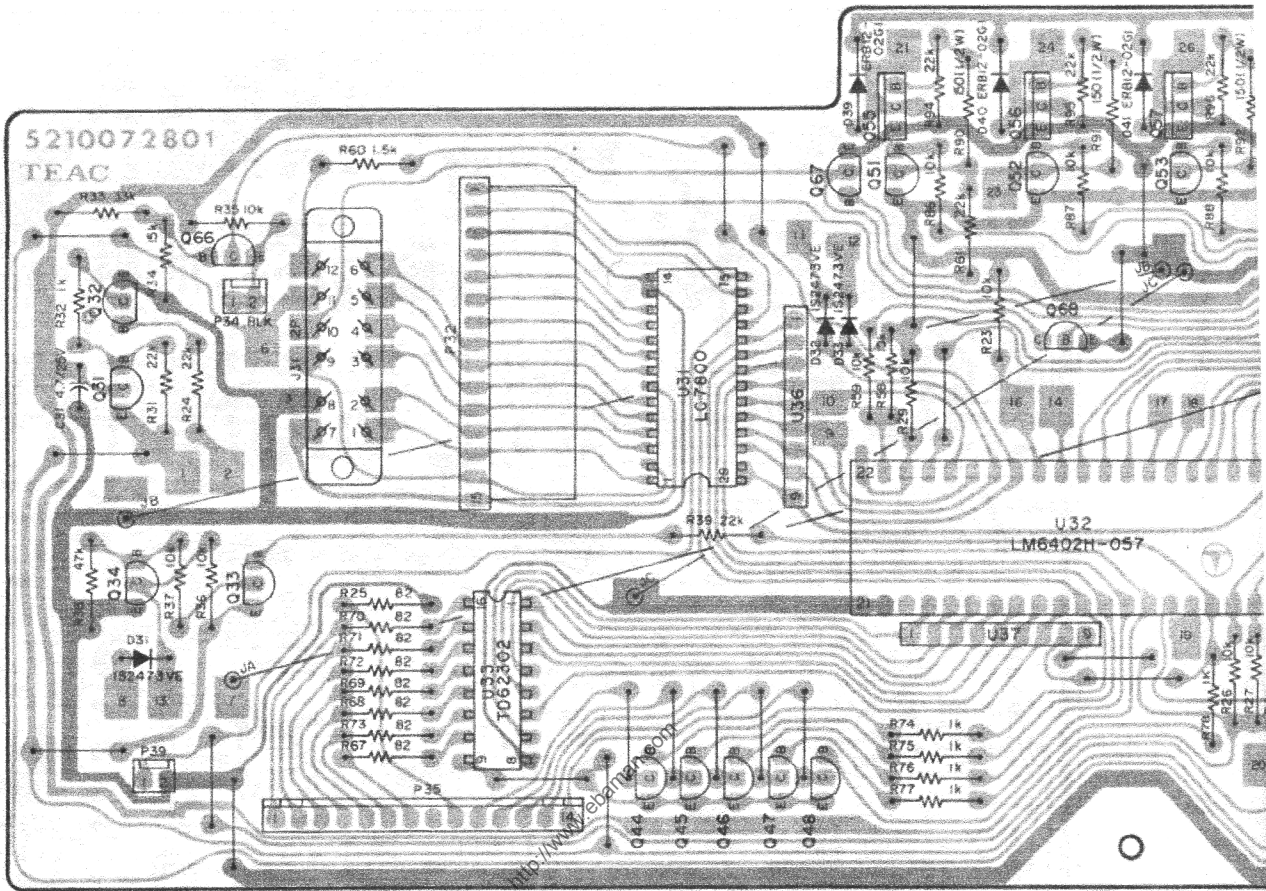

MIC AMPL. PCB ASSY

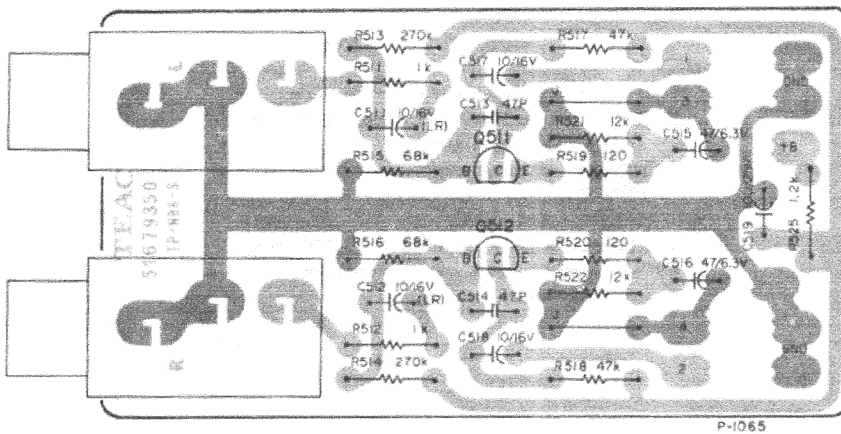

P-1065

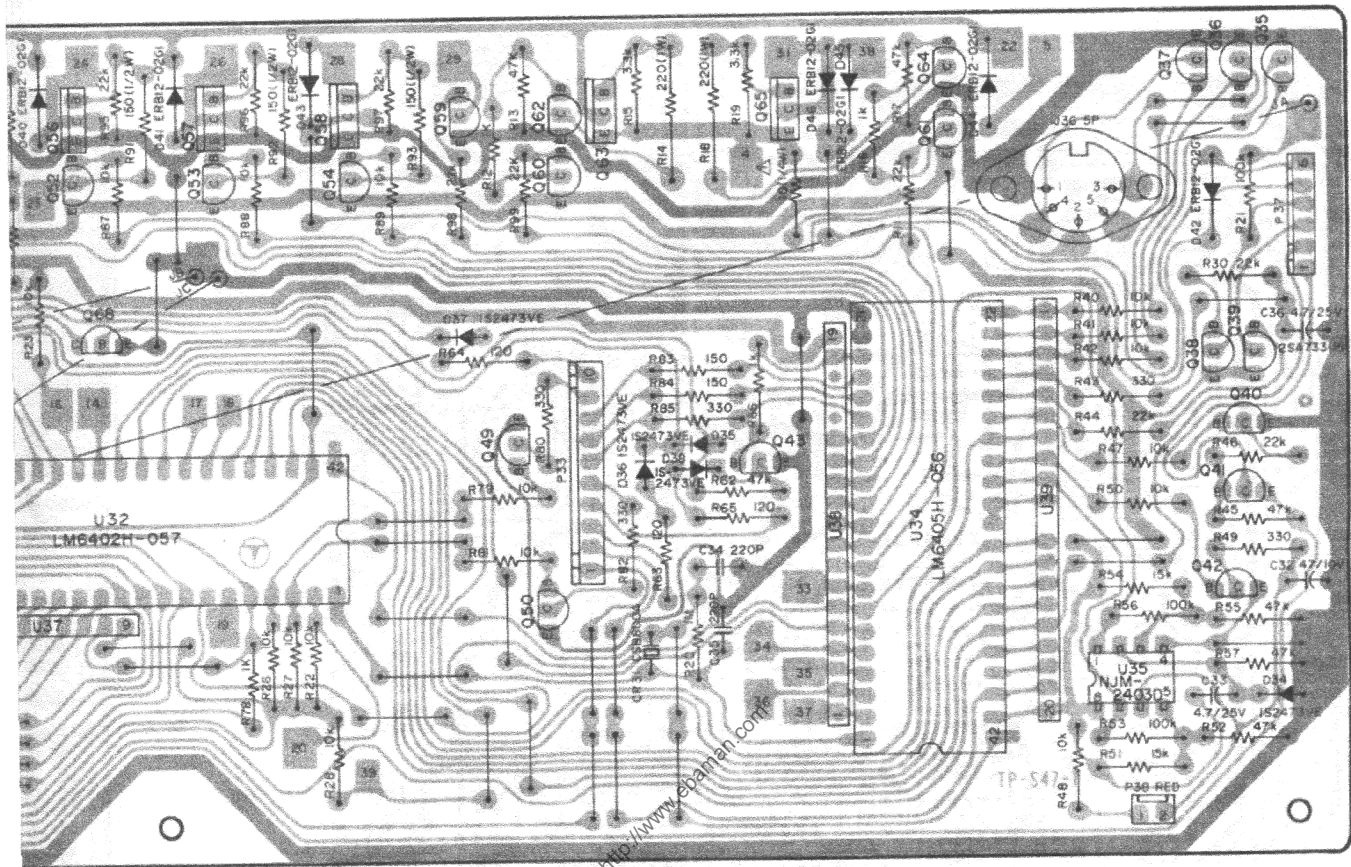

VOLUME PCB ASSY

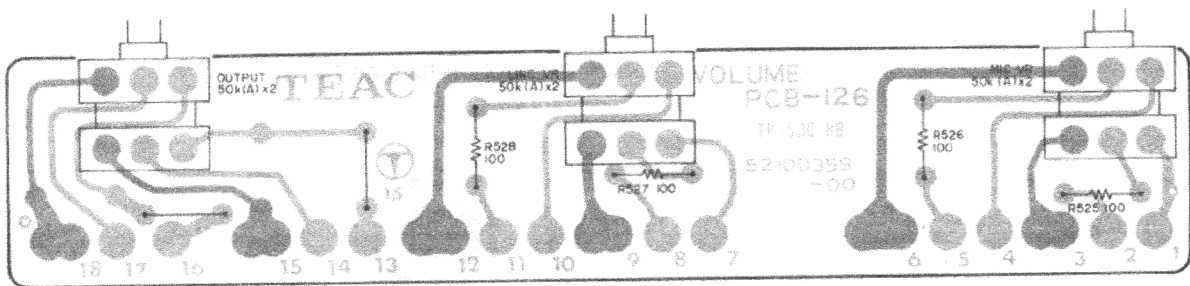

POWER/SERVO PCB ASSY

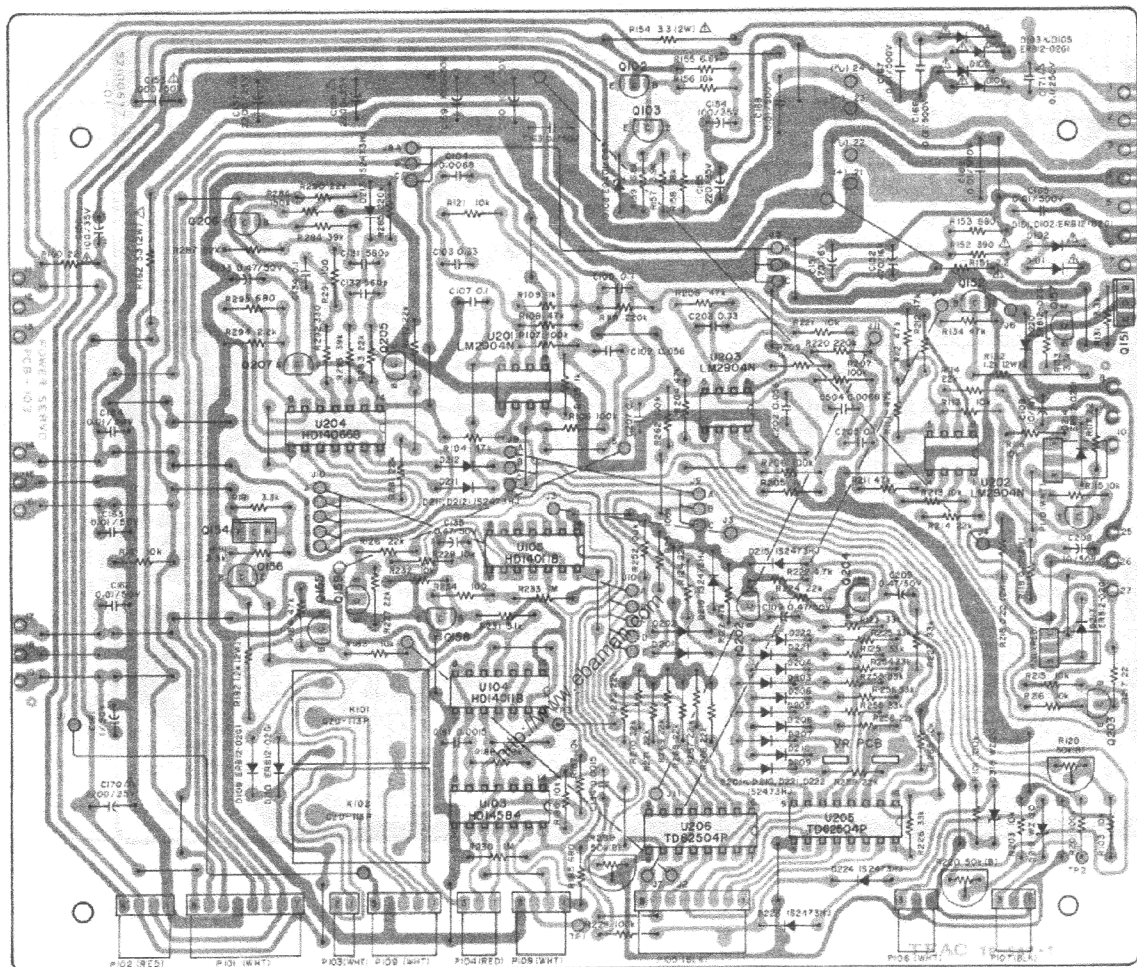

VR PCB ASSY (POWER/SERVO)



DBX PCB ASSY

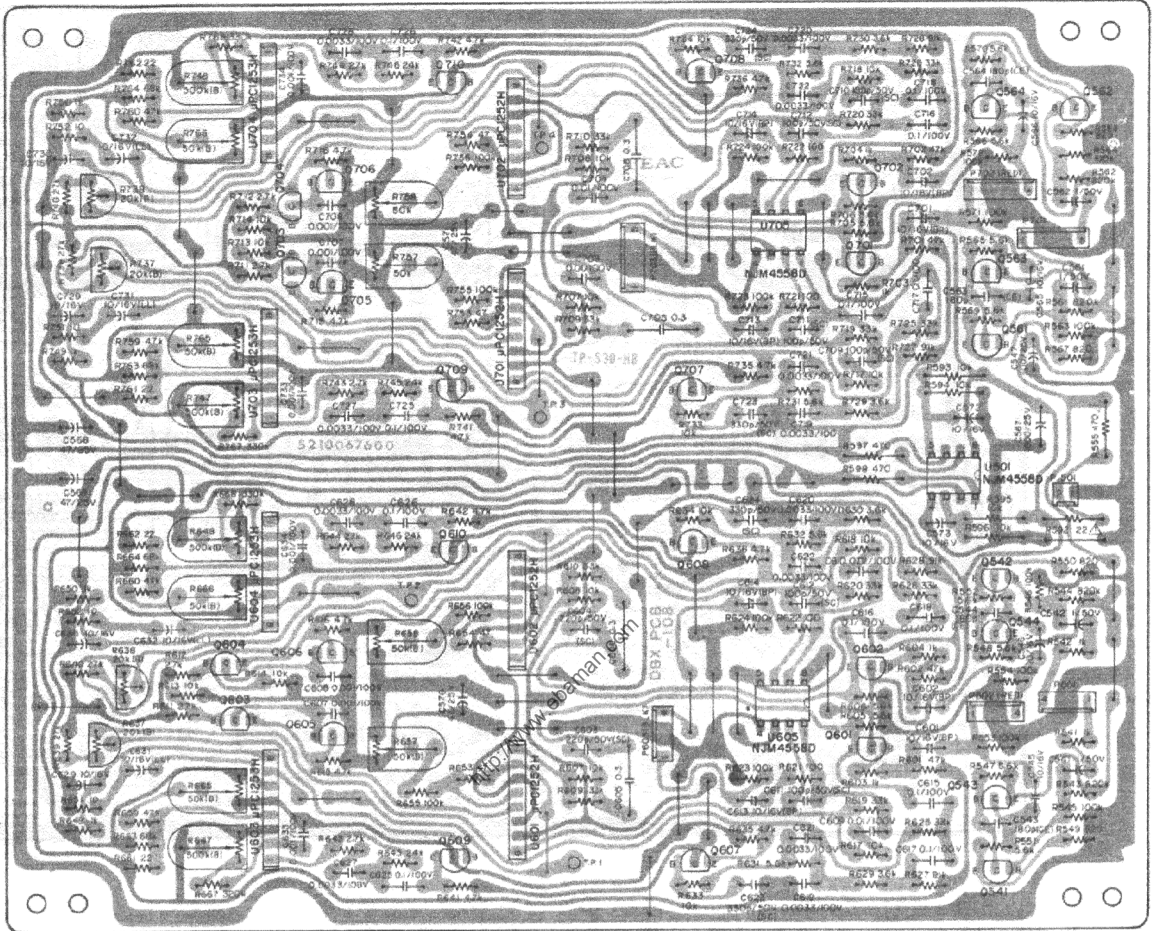

NOTES

1. PC Board shown viewed from foil side.
2. The colors used on the PCB illustrations have the following significance:
 - : +B power supply circuit
 - : GND
 - : Other
3. Resistor values are in ohms (k = 1,000 ohms).
4. All capacitor values are in microfarads (p = picofarads).

REC/PLAY AMPL. PCB ASSY

REF. NO.	PARTS NO.	DESCRIPTION
	5200072600	PCB Assy [GE, E, UK, A, L]
	5200072610	PCB Assy [U, C]
	5210072600	PCB [GE, E, UK, L]
	5210081400	PCB [U, C]
IC's		
U301, U303	6220410900	TA75558P
U302	7220412200	TA7557P
TRANSISTROS		
Q301, Q302	5042461000	2SC-1327T
Q303~Q308	5145036000	2SC-945LK
Q309~Q312	5145092000	2SC-1740LNS
Q313~Q315	5145185000	2SD-655E
Q317, Q318	5145185000	2SD-655E
Q319~Q326	5145036000	2SC-945LK
Q327~Q334	5145092000	2SC-1740LNS
Q337	5145036000	2SC-945LK
Q339	5145185000	2SC-655E
Q341	5145036000	2SC-945LK
Q342	5145150000	2SA-1015QR
Q351	5145036000	2SC-945LK
DIODES		
D301~D304	5042213000	1N60
D305~D308	5042517000	IS2473VE
D311	5042517000	IS2473VE
CARBON RESISTROS		
All resistors are rated $\pm 5\%$ tolerance and $\%W$.		
R301~R304	5183150000	680k Ω
R305~R306	5183082000	1k Ω
R307, R308	5183130000	100k Ω
R309, R310	5183082000	1k Ω
R311, R312	5183072000	390 Ω
R317, R318	5183144000	390k Ω
R319, R320	5183106000	10k Ω
R321, R322	5183106000	10k Ω
R323, R324	5183058000	1k Ω
R325, R326	5183140000	270k Ω
R323, R332	5183082000	1k Ω
R337~R340	5183098000	4.7k Ω
R341, R342	5183114000	22k Ω
R343, R344	5183090000	2.2k Ω
R345, R346	5183106000	10k Ω
R347, F348	5183114000	22k Ω
R349, R350	5183100000	5.6k Ω
R351, R352	5183114000	22k Ω
R335, R356	5183144000	390k Ω
R357, R358	5183124000	56k Ω
R359, R360	5183088000	1.8k Ω
R361, R362	5183144000	390k Ω
R363, R364	5183120000	39k Ω
R365, R366	5183100000	5.6k Ω
R367, R368	5183084000	1.2k Ω
R373, R374	Δ 5184265000	470 Ω Nonflammable
R375, R376	5185132000	47k Ω
R377, R378	5185136000	68k Ω
R379, R380	5183108000	12k Ω
R381, R382	5183774000	470 Ω
R383, R394	5183106000	10k Ω
R385, R386	5183088000	1.8k Ω
R387~R390	5183132000	120k Ω
R391, R392	5183122000	47k Ω
R393, R394	5183076000	560 Ω

REF. NO.	PARTS NO.	DESCRIPTION
R395~R398	5183138000	220k Ω
R399, R400	5183098000	4.7k Ω
R401, R402	5183106000	10k Ω
R405, R406	5183098000	4.7k Ω
R407, R408	5183062000	160 Ω
R409, R410	5183086000	220 Ω
R411, R412	5183136000	180k Ω
R413, R414	5183124000	56k Ω
R415, R416	5183090000	2.2k Ω
R417, R418	5183046000	33 Ω
R419, R420	5183082770	1k Ω
R421, R422	5183130000	100k Ω
R425, R426	5183132000	120k Ω
R427, R428	5183090000	2.2k Ω
R437~R440	5183062000	160 Ω
R441~R444	5183060000	120 Ω
R445~R452	5183114000	22k Ω
R453, R454	5183082000	1k Ω
R455~R458	5183138000	220k Ω
R459, R460	5183112000	18k Ω
R461, R462	5183110000	15k Ω
R463, R464	5183758000	100 Ω
R465, R466	5183130000	100k Ω
R467, R468	5183084000	1.2k Ω
R469, R470	5183090000	2.2k Ω
R471, R472	5183088000	1.8k Ω
R473, R474	5183090000	2.2k Ω
R475~R478	5183114000	22k Ω
R479	Δ 5184243000	56 Ω Nonflammable
R480	Δ 5184257000	15 Ω Nonflammable
R481	Δ 5184257000	220 Ω Nonflammable
R482	5183090000	2.2k Ω
R483	5183114000	22k Ω
R484	5183102000	6.8k Ω
R485	5183114000	22k Ω
R490	5183114000	22k Ω
R491	Δ 5181990000	47 Ω Nonflammable
R492	Δ 5181996000	82 Ω Nonflammable
R493	5183118000	33k Ω
R494	5183114000	22k Ω
R495	5183090000	2.2k Ω
R496	5183082000	1k Ω
R497	5183126000	68k Ω
R498	5183058000	100 Ω
R499, R500	5183098000	4.7k Ω
R501	5183098000	4.7k Ω
R502	5183106000	10k Ω
R503	Δ 5182020000	820 Ω Nonflammable
R504	Δ 5184255000	180 Ω Nonflammable
R508~R514	5183114000	22k Ω
R523	5183082000	1k Ω
R524	5183084000	1.2k Ω
CAPACITORS		
C305	5173034000	Elec. 47 μ F 6.3V
C306	5173010000	Elec. 10 μ F 16V
C311, C312	5171565000	Elec. 10 μ F 16V
C313, C314	5172304000	Ceramic 22pF 50V 10%
C315, C316	5173010000	Elec. 10 μ F 16V
C317, C318	5173034000	Elec. 47 μ F 6.3V
C319, C320	5154877570	Myler 0.01 μ F 100V 5%
C321, C322	5260226110	Elec. 1 μ F 50V 10%
C323, C324	5054924500	Myler 0.039 μ F 100V 5%
C325, C326	5054881500	Myler 0.0033 μ F 100V 5%

[U] : U.S.A.
[A] : AUSTRALIA
[L] : LIMITED AREA

[C] : CANADA
[E] : EUROPE

[GE] : GENERAL EXPORT
[UK] : U.K.

REF. NO.	PARTS NO.	DESCRIPTION
C327	5054877500	Myler 0.01 μ F 100V 5%
C329, C330	5054894500	Myler 0.0082 μ F 100V 5%
C331, C332	5173055000	Elec. 220 μ F 25V
C355, C356	5172992000	Elec. 1 μ F 50V
C539, C360	5172992000	Elec. 1 μ F 50V
C361, C362	5172300000	Ceramic 10pF 50V 20%
C363, C364	5172992000	Elec. 1 μ F 50V
C365	5173046000	Elec. 100 μ F 25V
C381, C382	5172992000	Elec. 1 μ F 50V
C383, C384	5173010000	Elec. 10 μ F 16V
C385, C386	5172312000	Ceramic 100pF 50V 10%
C387, C388	5260222010	Elec. 10 μ F 35V 20%
C389	5173046000	Elec. 100 μ F 25V
C391, C392	5172992000	Elec. 1 μ F 50V
C393, C394	5173010000	Elec. 10 μ F 16V
C395, C396	5054878500	Myler 0.001 μ F 100V 5%
C397, C398	5173037000	Elec. 47 μ F 25V
C399	5173046000	Elec. 100 μ F 25V
C401, C402	5173010000	Elec. 10 μ F 16V
C403, C404	5172308000	Ceramic 47 μ F 50V 10%
C405, C406	5173052000	Elec. 220 μ F 6.3V
C407, C408	5173004000	Elec. 4.7 μ F 25V
C409, C410	5173034000	Elec. 47 μ F 6.3V
C411	5173046000	Elec. 100 μ F 25V
C413, C414	5054876500	Myler 0.0022 μ F 100V 5%
C415	5173046000	Elec. 100 μ F 25V
C417	5173070000	Elec. 470 μ F 6.3V
C419	5054738500	Myler 0.047 μ F 100V 5%
C421, C422	5172992000	Elec. 1 μ F 50V
C423, C424	5173010000	Elec. 10 μ F 16V
C425, C426	5054930500	Myler 0.15 μ F 100V 5%
C427, C428	5260222010	Elec. 10 μ F 35V 20%
C429, C430	5054889500	Myler 0.0027 μ F 100V 5%
C431, C432	5172826000	Polyst 820pF 50V 5%
C433, C434	5054889500	Myler 0.0027 μ F 100V 5%
C435, C436	5054877500	Myler 0.01 μ F 100V 5%
C437	5173055000	Elec. 220 μ F 25V
C441, C442	5054877500	Myler 0.01 μ F 100V 5%
C443, C444	5054887500	Myler 0.015 μ F 100V 5%
C445, C446	5054894500	Myler 0.0082 μ F 100V 5%
C447, C448	5054877500	Myler 0.01 μ F 100V 5%
C450, C451	5173011000	Elec. 10 μ F 25V
C455, C456	5172794000	Polyst 39pF 50V 5%
C457, C458	5172792000	Plyst 33pF 50V 5%
VARIABLE RESISTORS		
R313~R316	5280003302	Semi-fixed 5k Ω (B)
R327~R330	5280003602	Semi-fixed 10k Ω (B)
R333~R336	5280003302	Semi-fixed 5k Ω (B)
R369, R370	5280003802	Semi-fixed 30k Ω (B)
R371, R372	5180003602	Semi-fixed 20k Ω (B)
R403, R404	5280003502	Semi-fixed 10k Ω (B)
R429~R432	5280003602	Semi-fixed 20k Ω (B)
R515~R522	5280004202	Semi-fixed 100k Ω (B)
COILS		
L301, L302	5160107000	Choke, 1200 μ F 5%
L303, L304	5056637000	Trap, 3mH 20%
L305~L308	5056637000	Record; EQ, 2.4-4.2 mH20%
SWITCHES		
S302	5134094000	Push, 2-2
S306	5134095000	Push, 4-2
S307, S309	5131044000	Slide, 9-2
S308	5131046900	Slide, 6-2

REF. NO.	PARTS NO.	DESCRIPTION
CONNECTOR PLUG		
P301, P304	5122128000	4P
P302	5122301000	4P (RED)
P303	5122132000	8P
MISCELLANEOUS		
K301	5061237000	Relay, Reed; LAB2L 12V
K302	5290009400	Relay, G2V-282P 24V
U305	5040090000	OSC Unit

CONTROL PCB ASSY

REF. NO.	PARTS NO.	DESCRIPTION
	5200066900	PCB Assy [GE, E, UK, A, L,]
	5200066910	PCB Assy [U, C]
	5210066900	PCB [GE, E, UK, A, L,]
	5210072800	PCB [U, C]
IC's		
U31	5220019700	LC7800
U32	5220803400	LM6402A
U33	5220015600	TD62302P
U34	5220803500	OM6405A
U35	5147055000	NJM-2403D
U36, U37	5293002500	01-0299
U38	5293002600	01-0396
U39	5293002700	01-0397
TRANSISTORS		
Q31	5230016100	2SA-950Y
Q32	5042383000	2SC-536F
Q33	5042553000	2SA-733P
Q34, Q37	5042383000	2SC-536F
Q38, Q39	5042553000	2SA-733P
Q40	5042383000	2SC-536F
Q41	5042553000	2SA-733P
Q42, Q43	5042383000	2SC-536F
Q44, Q48	5230016100	2SA-950Y
Q49, Q50	5142383000	2SC-536F
Q51, Q54	5042553000	2SA-733P
Q55, Q58	5042564000	2SC-1061C
Q59	5042383000	2SC-536F
Q60, Q61	5042553000	2SA-733P
Q62	5042625000	2SC-1318S
Q63	5145129000	2SB-507E
Q64	5042625000	2SC-1318S
Q65	5145129000	2SB-507E
Q66, Q68	5042383000	2SC-536F
DIODES		
D31, D38	5042517000	192473VE
D39, D46	5143243000	ERB12-02G1

[U] : U.S.A.
[A] : AUSTRALIA
[L] : LIMITED AREA

[C] : CANADA
[E] : EUROPE

[GE] : GENERAL EXPORT
[UK] : U.K.

REF. NO.	PARTS NO.	DESCRIPTION
RESISTORS		
All resistors are rated $\pm 5\%$ tolerance, $\%W$ and of carbon type unless otherwise noted.		
R11	5183114000	22 k Ω
R12	5183082000	1 k Ω
R13	5183122000	47 k Ω
R14	5184763000	220 Ω
R15	5183094000	3.3 k Ω
		1W Metal Film
R16	5183082000	1 k Ω
R17	5183122000	47 k Ω
R18	5184763000	220 Ω
R19	5183094000	3.3 k Ω
R20	5183154000	1M Ω
		1W Metal Film
R21	5183130000	100 k Ω
R22, R23	5183106000	10 k Ω
R24	5183114000	22 k Ω
R25	5183056000	82 Ω
R26, R29	5183106000	10 k Ω
R30	5183114000	22 k Ω
R32	5183082000	1 k Ω
R33	5183118000	33 k Ω
R34	5183110000	15 k Ω
R35, R37	5183106000	10 k Ω
R38,	5183122000	47 k Ω
R39	5183114000	22 k Ω
R43	5183070000	330 Ω
R40, R42	5183106000	10 k Ω
R44	5183114000	22 k Ω
R45	5183122000	47 k Ω
R46	5183114000	22 k Ω
R47, R48	5183106000	10 k Ω
R49	5183070000	330 Ω
R50	5183106000	10 k Ω
R51	5183110000	15 k Ω
R52	5183122000	47 k Ω
R53	5183130000	100 k Ω
R54	5183110000	15 k Ω
R55	5183122000	47 k Ω
R56	5183130000	100 k Ω
R57	5183122000	47 k Ω
R58	5183106000	10 k Ω
R59	5183082000	1 k Ω
R60	5183086000	1.5 k Ω
R61	5183106000	10 k Ω
R62	5183122000	47 k Ω
R63, R65	5183060000	120 Ω
R66	5183082000	1 k Ω
R67, R73	5183056000	82 Ω
R74, R78	5183082000	1 k Ω
R79	5183106000	10 k Ω
R80	5183070000	330 Ω
R81	5183106000	10 k Ω
R82	5183070000	330 Ω
R83, R84	5183062000	150 Ω
R85	5183062000	150 Ω
R86, R89	5183106000	10 k Ω
R90, R93	5187062000	150 Ω
R94, R99	5183114000	22 k Ω

REF. NO.	PARTS NO.	DESCRIPTION
CAPACITORS		
C31	5172894000	Elec. 4.7 μ F 25V
C32	5172924000	Elec. 47 μ F 10V
C33	5172894000	Elec. 4.7 μ F 25V
C34, C35	5054342000	Polyst 220pF 50V 10%
C36	5172894000	Elec. 4.7 μ F 25V
CONNECTOR PLUG		
P32	5122158000	15P
P33	5122134000	10P
P34	5122183000	2P (BLK)
P35	5122138000	14P
P37	5122130000	6P
P38	5122299000	2P (RED)
P39	5122126000	2P
MISCELLANEOUS		
CR31	5347000600	CSB800A

MIC AMPL. PCB ASSY

REF. NO.	PARTS NO.	DESCRIPTION
	5200045500	PCB Assy
	5167935000	PCB
TRANSISTORS		
Q511, Q512	5042461000	2SC-1327T
CARBON RESISTORS		
All resistors are rated $\pm 5\%$ tolerance and $\%W$.		
R511, R512	5183082000	1 k Ω
R513, R514	5183140000	270 k Ω
R515, R516	5183126000	68 k Ω
R517, R518	5183122000	47 k Ω
R519, R520	5183060000	120 Ω
R521, R22	5183108000	12 k Ω
R525	5183084000	1.2 k Ω
CAPACITORS		
C511, C512	5170077000	Elec. 10 μ F 16V
C513, C514	5172300000	Ceramic 10 μ F 50V 10%
C517, C518	5055405000	Elec. 40 μ F 16V
C519	5055417000	Elec. 100 μ F 25V
MISCELLANEOUS		
	5124045000	Jack, MIC

http://www.ebar.com

VR PCB ASSY

REF. NO.	PARTS NO.	DESCRIPTION
	5200035900	PCB Assy
	5120035900	PCB
CARBON RESISTORS		
R525~R528	5183058000	100Ω ¼W 5%
VARIABLE RESISTORS		
R529, R530	5282706002	Semi-fixed 50kΩ(A)
R537~R540	5282706002	Semi-fixed 50kΩ(A)

POWER/SERVO PCB ASSY

REF. NO.	PARTS NO.	DESCRIPTION
	5100079100	PCB Assy
	5210079100	PCB
IC's		
U103	5220019800	HD14584B
U104, U105	5220015900	HD140118P
U201~U203	5220407200	LM2904N
U204	5220017100	HD140668P
U205, U206	5293000900	TD62504P
TRANSISTORS		
Q102	5042625000	2SC-1318S
Q103	5042383000	2SC-536F
Q151	5145129000	2SB-507E
Q152	5042625000	2SC-1318S
Q154	5145129000	2SB-507E
Q155	5042625000	2SC-1318S
Q156, Q157	5145150000	2SA-1015GR
Q158, Q159	5145151000	2SC-1815GR
Q201, Q203	5145151000	2SC-1815GR
Q202, Q204	5145150000	2SA-1015GR
Q205	5145151000	2SC-1815GR
Q206	5145150000	2SA-1015GR
Q207	5145102000	2SK-68AL
DIODES		
D101~D106	5143243000	ERB12-02G1
D108	5143154000	Zener, EQA01-06S
D109, D110	5143243000	ERB12-02G1
D201~D213	5143118000	1S2473HJ
D214, D217	5143243000	ERB12-02G1
D215, D216	5143118000	1S2473HJ
D218, D219	5042515000	Zener, WZ-090
D220	5143243000	ERB12-02G1
D221~D224	5143118000	1S2473HJ

REF. NO.	PARTS NO.	DESCRIPTION
RESISTORS		
All resistors are rated ±5% tolerance, ¼W and of carbon type unless otherwise noted.		
R101, R201	5183130000	100kΩ
R103, R203	5183106000	10kΩ
R104, R204	5183122000	47kΩ
R105, R205	5183082000	1kΩ
R106, R206	5183130000	100kΩ
R107, R207	5183130000	100kΩ
R108, R208	5183122000	47kΩ
R109, R209	5183082000	1kΩ
R110, R210	5183138000	220kΩ
R111, R211	5183122000	47kΩ
R112, R212	5183122000	47kΩ
R113, R213	5183106000	10kΩ
R114, R214	5183114000	22kΩ
R115, R215	5183106000	10kΩ
R116, R216	5183106000	10kΩ
R117, R217	5183042000	22Ω
R118, R218	5185190000	0.22Ω
R121, R221	5183106000	10kΩ
R122, R222	5183122000	47kΩ
R123, R223	5183118000	33kΩ
R124, R224	5183114000	22kΩ
R125, R225	5183118000	33kΩ
R126	5183114000	22kΩ
R131, R133	5183094000	3.3kΩ
R132	5184816000	1.2kΩ
R134	5183122000	47kΩ
R151	Δ5184209000	2.2Ω
R152	5183072000	390Ω
R153	5183078000	680Ω
R154	5184308000	3.3Ω
R155	5183102000	6.8kΩ
R156	5183106000	10kΩ
R157	5183098000	3.9kΩ
R158	5183112000	18kΩ
R159	5183102000	6.8kΩ
R160	Δ5184233000	22Ω
R161	5183106000	10kΩ
R162	5184308000	3.3Ω
R181	5183094000	3.3kΩ
R182	5184816000	1.2kΩ
R183	5183106000	10kΩ
R184	5183122000	47kΩ
R185	5183078000	68Ω
R186, R187	5183106000	10kΩ
R188	5183130000	100kΩ
R191	5183094000	3.3kΩ
R226	5183118000	33kΩ
R227	5183114000	22kΩ
R228	5183130000	100kΩ
R229	5183106000	10kΩ
R230	5183154000	1MΩ
R231	5183099000	5.1kΩ
R232	5183106000	10kΩ
R233	5183154000	1MΩ
R234	5183058000	100Ω
R235	5183130000	100kΩ
R251, R252	5183130000	100kΩ
R253~R256	5183118000	33kΩ
R258, R259	5183114000	22kΩ
R261, R262	5183130000	100kΩ

DBX PCB ASSY

REF. NO.	PARTS NO.	DESCRIPTION
R265	5183106000	10 kΩ
R266~R272	5183114000	22 kΩ
R281~R283	5183114000	22 kΩ
R284	5183120000	39 kΩ
R285	5183138000	220 kΩ
R286	5183134000	150 kΩ
R287	5183114000	22 kΩ
R290	5183114000	22 kΩ
R291	5183058000	100Ω
R292	5183070000	330Ω
R293	5183120000	39 kΩ
R294	5183090000	2.2 kΩ
R295	5183078000	680Ω
CAPACITORS		
C102, C202	5170513000	Mylar 0.056μF 100V 10%
C103, C203	5170631000	Mylar 0.33μF 100V 10%
C104, C204	5170491000	Mylar 0.068μF 100V 10%
C105, C205	5170519000	Mylar 0.1μF 100V 10%
C107, C207	5170519000	Mylar 0.1μF 100V 10%
C108, C208	5173013000	Elec. 10μF 50V
C109, C209	5172992000	Elec. 1μF 50V
C131, C132	5171237000	Elec. 569pF 125V 10%
C133	5172992000	Elec. 0.47μF 50V
C134	5170519000	Mylar 0.1μF 100V 10%
C135	5172990000	Elec. 0.47μF 50V
C136	5170475000	Mylar 0.0015μF 100V 10%
C151, C152	5173072000	Elec. 470μF 18V
C153	5172973000	Elec. 1000μF 50V
C154	5173047000	Elec. 100μF 35V
C155	5173056000	Elec. 220μF 35V
C156	5173047000	Elec. 100μF 35V
C157, C158	5172978000	Elec. 2200μF 25V
C159, C160	5172973000	Elec. 1000μF 50V
C161	5172992000	Elec. 1μF 50V
C162	5172336000	Ceramic 0.01μF 50V 20%
C163	5172348000	Ceramic 0.1μF 50V 10%
C164	5172336000	Ceramic 0.01μF 50V 20%
C165~C169	5267010300	Ceramic 10000pF 500V
C170	5172978000	Elec. 2200μF 25V
C191	5183094000	Mylar 0.0015μF 100V 10%
VARIABLE RESISTORS		
R120, R220	5280001502	Semi-fixed 50 kΩ(B)
R289	5280001502	Semi-fixed 50 kΩ(B)
CONNECTOR PLUG		
P101	5122151000	8P
P102	5122455000	4P (RED)
P103	5122145000	2P
P104	5122454000	3P (RED)
P105	5122208000	8P (BLK)
P106	5122146000	3P
P107	5122203000	3P (BLK)
P108	5122147000	4P
P109	5122148000	5P
P110	5122147000	3P
P111	5122454000	3P (RED)
RELAYS		
K101, K102	5061144000	G2U-113P 24V

REF. NO.	PARTS NO.	DESCRIPTION
	5100067600	PCB Assy [GE, E, UK, A, L]
	5200067610	PCB Assy [U, C]
	5210067600	PCB [GE, E, UK, A, L]
	5210072700	PCB [U, C]
IC's		
U501	5042738000	NJM4558D
U601, U602	5220414500	UPC1252H
U603, U604	5220414600	UPC1253H
U605	5042738000	NJM4558D
U701, U702	5220414500	UPC1252H
U703, U704	5220414600	UPC1253H
U705	5042738000	NJM 4558D
TRANSISTORS		
Q541, Q542	5145151000	2SC-1815GR
Q543, Q544	5145132000	2SA-933LNS
Q561, Q562	5145151000	2SC-1815GR
Q563, Q564	5145132000	2SC-933LNG
Q601, Q602	5145151000	2SC-1815GR
Q603, Q604	5145150000	2SA-1015GR
Q605~Q608	5145151000	2SC-1815GR
Q609, Q610	5145150000	2SA-1015GR
Q701, Q702	5145151000	2SC-1815GR
Q703, Q704	5145150000	2SA-1015GR
Q705~Q708	5145151000	2SC-1815GR
Q709, Q710	5145150000	2SA-1015GR
CARBON RESISTORS		
All resistors are rated ±5% tolerance and %W.		
R541, R542	5240028200	4 kΩ
R543, R544	5240035200	820 kΩ
R545, R546	5240033000	100 kΩ
R547, R548	5240030000	5.6 kΩ
R549, R550	5240028000	820Ω
R551, R552	5240030000	5.6 kΩ
R553, R554	5240033000	100 kΩ
R555	△5184285000	470Ω
R556, R557	5240035200	820 kΩ
R558, R559	5240033000	100 kΩ
R560, R561	5240033000	100 kΩ
R562, R563	5240033000	100 kΩ
R564, R565	5240033000	100 kΩ
R566, R567	5240030000	5.6 kΩ
R568, R569	5240028000	820Ω
R570, R571	5240030000	5.6 kΩ
R572, R573	5240033000	100 kΩ
R574, R575	△5184233000	22Ω
R576, R577	5240033000	100 kΩ
R578, R579	5240033000	100 kΩ
R580, R581	5240033000	100 kΩ
R582, R583	5240033000	100 kΩ
R584, R585	5240033000	100 kΩ
R586, R587	5240033000	100 kΩ
R588, R589	5240033000	100 kΩ
R590, R591	5240033000	100 kΩ
R592, R593	5240033000	100 kΩ
R594, R595	5240033000	100 kΩ
R596, R597	5240033000	100 kΩ
R598, R599	5240033000	100 kΩ
R600, R601	5240033000	100 kΩ
R602, R603	5240033000	100 kΩ
R604, R605	5240033000	100 kΩ
R606, R607	5240033000	100 kΩ
R608, R609	5240033000	100 kΩ
R610, R611	5240033000	100 kΩ
R612, R613	5240033000	100 kΩ
R614, R615	5240033000	100 kΩ
R616, R617	5240033000	100 kΩ
R618, R619	5240033000	100 kΩ
R620, R621	5240033000	100 kΩ
R622, R623	5240033000	100 kΩ
R624, R625	5240033000	100 kΩ
R626, R627	5240033000	100 kΩ

[U]: U.S.A.
[A]: AUSTRALIA
[L]: LIMITED AREA

[C]: CANADA
[E]: EUROPE

[GE]: GENERAL EXPORT
[UK]: U.K.

REF. NO.	PARTS NO.	DESCRIPTION
R627, R628	5240032900	91 kΩ
R629, R630	5240029500	3.6 kΩ
R631, R632	5240030000	5.6 kΩ
R633, R634	5240030600	10 kΩ
R635, R636	5240029800	4.7 kΩ
R639, R640	5240031600	27 kΩ
R641, R642	5240029800	4.7 kΩ
R643, R644	5240029200	2.7 kΩ
R645, R646	5240031500	24 kΩ
R649, R650	5240028200	1 kΩ
R651, R652	5240023400	1 kΩ
R653, R654	5240025000	47Ω
R655, R656	5240033000	100 kΩ
R659, R660	5240032200	47 kΩ
R661, R662	5240024200	22Ω
R663, R664	5240032600	68 kΩ
R667, R668	5240034200	330 kΩ
R701, R702	5240032200	47 kΩ
R703, R704	5240028200	1 kΩ
R705, R706	5240030000	5.6 kΩ
R707, R708	5240030600	10 kΩ
R709, R710	5240031800	33 kΩ
R711, R712	5240029200	2.7 kΩ
R713, R714	5240030600	10 kΩ
R715, R716	5240029800	4.7 kΩ
R717, R718	5240030600	10 kΩ
R719, R720	5240031800	33 kΩ
R721, R722	5240025800	100Ω
R723, R724	5240033000	100 kΩ
R725, R726	5240031800	33 kΩ
R727, R728	5240032900	91 kΩ
R729, R730	5240029500	3.6 kΩ
R731, R732	5240030000	5.6 kΩ
R733, R734	5240030600	10 kΩ
R735, R736	5240029800	4.7 kΩ
R739, R740	5240031600	27 kΩ
R741, R742	5240029800	4.7 kΩ
R743, R744	5240029200	2.7 kΩ
R745, R746	5240031500	24 kΩ
R749, R750	5240028200	1 kΩ
R751, R752	5240023400	10Ω
R753, R754	5240025000	47Ω
R755, R756	5240033000	100 kΩ
R759, R760	5240032200	47 kΩ
R761, R762	5240024200	22Ω
R763, R764	5240032800	68 kΩ
R767, R768	5240034200	330 kΩ
CAPACITORS		
C601, C602	5171482000	Elec. 10μF 16V
C603, C604	5172316000	Ceramic 220pF 50V 10%
C605, C606	5170480000	Mylar 0.3μF 100V 5%
C607, C608	5170401000	Mylar 0.001μF 100V 5%
C609, C610	5170425000	Mylar 0.01μF 100V 5%
C611, C612	5172312000	Ceramic 100pF 50V 10%
C613, C614	5171482000	Elec. 10μF 16V
C615~C618	5170449000	Mylar 0.1μF 100V 5%
C619~C622	5170413000	Mylar 0.0033μF 100V 5%
C623, C624	5172318000	Ceramic 330pF 50V 10%

REF. NO.	PARTS NO.	DESCRIPTION
C625, C626	5170449000	Mylar 0.1μF 100V 5%
C627, C628	5170413000	Mylar 0.0033μF 100V 5%
C629, C630	5173010000	Elec. 10μF 16V
C631, C632	5280221910	Elec. 10μF 16V 20%
C633, C634	5170401000	Mylar 0.001μF 100V 5%
C701, C702	5171482000	Elec. 10μF 16V
C703, C704	5170425000	Mylar 0.01μF 100V 5%
C705, C706	5170480000	Mylar 0.3μF 100V 5%
C707, C708	5170401000	Mylar 0.001μF 100V 5%
C709~C712	5172312000	Ceramic 100pF 50V 10%
C713, C714	5171482000	Elec. 10μF 16V
C715~C718	5170449000	Mylar 0.1μF 100V 5%
C719~C722	5170413000	Mylar 0.0033μF 100V 5%
C723, C724	5172318000	Ceramic 330pF 50V 10%
C725, C726	5170449000	Mylar 0.1μF 100V 5%
C727, C728	5170413000	Mylar 0.0033μF 100V 5%
C729, C730	5173010000	Elec. 10μF 16V
C731, C732	5280221910	Elec. 10μF 16V 10%
C733, C734	5170401000	Mylar 0.001μF 100V 5%
VARIABLE RESISTORS		
R637, R638	5280001102	Semi-fixed 20 kΩ(B)
R647, R648	5150286000	Semi-fixed 500 kΩ(B)
R657, R658	5280004002	Semi-fixed 50 kΩ(B)
R665, R666	5280004002	Semi-fixed 50 kΩ(B)
R737, R738	5280001102	Semi-fixed 20 kΩ(B)
R747, R748	5150286000	Semi-fixed 500 kΩ(B)
R757, R758	5280004002	Semi-fixed 50 kΩ(B)
R765, R766	5280004002	Semi-fixed 50 kΩ(B)
CONNECTRO PLUG		
P501	5122126000	2P
P601	5122128000	4P
P602	5122301000	4P (RED)
P603	5122185000	4P (BLK)
P701	5122129000	5P
P702	5122302000	5P (RED)
P703	5122186000	5P (BLK)

VR PCB ASSY (POWER/SERVO)

REF. NO.	PARTS NO.	DESCRIPTION
	5200083800	PCB Assy
	5210083800	PCB
CARBON RESISTORS		
R257, R260	5183118000	33KΩ ¼W 5%
VARIABLE RESISTORS		
R237, R238	5280003502	10 kΩ(B)

KEYBOARD PCB ASSY (PC Board omitted.)

REF. NO.	PARTS NO.	DESCRIPTION
	5200067001	PCB Assy
	5210067001	PCB
S810, S824	5302101600	Tact Switch
D810, D813	5225010500	LED GL-5HD22
D814, D815	5225006900	LED SLP-151B
D816, D817	5225005800	LED SLP-251B

TENSION SENSOR PCB ASSY (PC Board omitted.)

REF. NO.	PARTS NO.	DESCRIPTION
	5200067402	PCB Assy
	5210067402	PCB
RESISTORS		
All resistors are rated $\pm 5\%$ tolerance, $\frac{1}{4}W$ and of carbon type unless otherwise noted.		
R811~R813	5183060000	120 Ω
R814	5241151800	33k Ω $\frac{1}{4}W$ Metal Film
MISCELLANEOUS		
U810	5228007000	Interrupter, PH101

DBX SWITCH PCB ASSY (PC Board omitted.)

REF. NO.	PARTS NO.	DESCRIPTION
	5200072400	PCB Assy
	5210072400	PCB
TRANSISTORS		
Q501, Q502	5145185000	2SD-655E
CARBON RESISTORS		
R501, R502	5183100000	5.6k Ω $\frac{1}{4}W$ 5%
SWITCH		
S501	5134093000	Push, 6-2

TIMER PCB ASSY (PC Board omitted.)

REF. NO.	PARTS NO.	DESCRIPTION
	5200067300	PCB Assy
	5210067300	PCB
DIODE		
D801	5143243000	ERB12-02G1
MISCELLANEOUS		
S803, S804	5134091000	Push Switch 2-2
P803	5122129000	Connector Plug, 5P
P808	5122128000	Connector Plug, 4P

ROLLER SENSOR PCB ASSY (PC Board omitted.)

REF. NO.	PARTS NO.	DESCRIPTION
	5200067201	PCB Assy
	5210067201	PCB
U801, U802	5228007100	Interrupter, ON1122

SPEED SW PCB ASSY (PC Board omitted.)

REF. NO.	PARTS NO.	DESCRIPTION
	5200067100	PCB Assy
	5210067100	PCB
S801, S802	5300019900	Push Switch 4-2
P801	5122149000	Connector Plug, 6P
P804	5122146000	Connector Plug, 3P
P806	5122454000	Connector Plug, 3P (RED)

AUTO REVERSE PCB ASSY (PC Board omitted.)

REF. NO.	PARTS NO.	DESCRIPTION
	5200067500	PCB Assy
	5210067500	PCB
S805	5133013000	Rotary Switch 2-3
P802	5122203000	Connector Plug, 3P (BLK)

PITCH CONTROL PCB ASSY (PC Board omitted.)

REF. NO.	PARTS NO.	DESCRIPTION
	5200072300	PCB Assy
	5210072300	PCB
	5150239000	Var, Res 5k Ω (B)

FUSE PCB ASSY (PC Board omitted.)

REF. NO.	PARTS NO.	DESCRIPTION
	5168997000	FUSE PCB Assy [U, C]
F1, F2	△5307004700	Fuse 7A 125V
F3	△5307004100	Fuse 2A 250V
	5041237000	Fuse Holder
	5158105000	Fuse PCB Assy [E, UK, A]
	5157105000	PCB Assy
	△5142193000	Mini Fuse 5A 250V
	△5142189000	Mini Fuse 2A 250V
	5142087000	Fuse Holder

DIODE PCB ASSY (PC Board omitted.)

REF. NO.	PARTS NO.	DESCRIPTION
	5200079000	PCB Assy
	5210079000	PCB
		DIODE
D107	△5228008000	BA60-B1D

IN/OUTPUT TERMINAL PCB ASSY (PC Board omitted.)

REF. NO.	PARTS NO.	DESCRIPTION
	5200036000	PCB Assy
	5167987101	PCB
	5124058000	Jack, 4P
		CARBON RESISTORS
R535, R536	5183120000	39 kΩ ¼W 5%

LED PCB ASSY (PC Board omitted.)

REF. NO.	PARTS NO.	DESCRIPTION
	5200072500	PCB Assy
	5210072500	PCB
D501, D502	5225006700	LED TLG124A (GREEN)

TRANSISTOR B PCB ASSY (PC Board omitted.)

REF. NO.	PARTS NO.	DESCRIPTION
	5200079100	PCB Assy
	5210079100	PCB
		IC's
U820	△5147058000	NJM-78M05A
U821	△5220413100	NJM-78M15A
		TRANSISTOR
Q820	△5145087000	2SD-313E
		CAPACITORS
C820 ~ C823	5172992000	Elec. 1μF 50V
		MISCELLANEOUS
	5033291000	Plate, Insulating
	5033295000	Tube, Insulating

TRANSISTOR PCB ASSY (PC Board omitted.)

REF. NO.	PARTS NO.	DESCRIPTION
	5200073100	PCB Assy
	5210073100	PCB
Q801	5145171000	Transistor, 2SD7180

[U]: U.S.A.
 [A]: AUSTRALIA
 [L]: LIMITED AREA

[C]: CANADA
 [E]: EUROPE

[GE]: GENERAL EXPORT
 [UK]: U.K.

SEMICONDUCTOR ELECTRODES

<p>LM6402A LM6405A</p> <p>(TOP VIEW)</p>	<p>LC7800</p> <p>(TOP VIEW)</p>	<p>TD62302A TD62504P</p> <p>(TOP VIEW)</p>	<p>HD14011BP HD14066BP HD14584B</p> <p>(TOP VIEW)</p>	<p>TA75558P</p> <p>(TOP VIEW)</p>	<p>LM2904N</p> <p>(TOP VIEW)</p>
<p>NJM2403D NJM4558D</p> <p>(TOP VIEW)</p>	<p>μPC1252H μPC1253H</p> <p>(SIDE VIEW)</p>	<p>NJM78M05A NJM78M15A</p>	<p>2SA733(P) 2SA933LN(S) 2SA950(Y) 2SA1015(GR)</p>	<p>2SB507(E)</p>	<p>2SC536(F)</p>
<p>2SC1061(C)</p>	<p>2SC945L(K) 2SC1318(S) 2SC1327(T) 2SC1740LN(S) 2SC1815G(R) 2SD655E</p>	<p>2SD313(E)</p>	<p>2SD718(O)</p>	<p>DBA60C</p> <p>(BOTTOM VIEW)</p>	
<p>1S2473HJ 1S2473VE</p>	<p>1N60</p>	<p>EQA01-06S</p>	<p>ERB12-02G1</p>	<p>WZ-090</p>	

Control PCB, Top

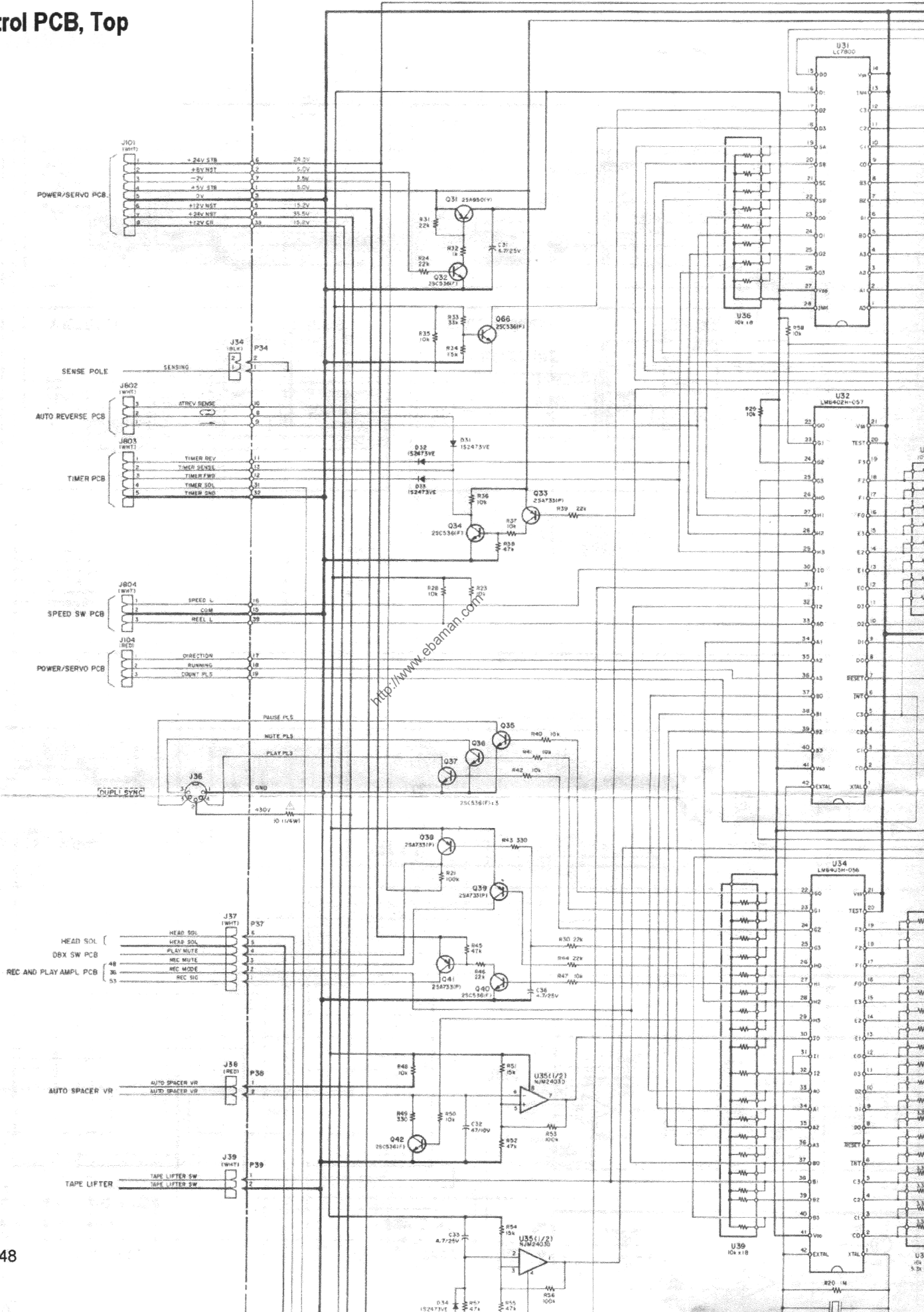

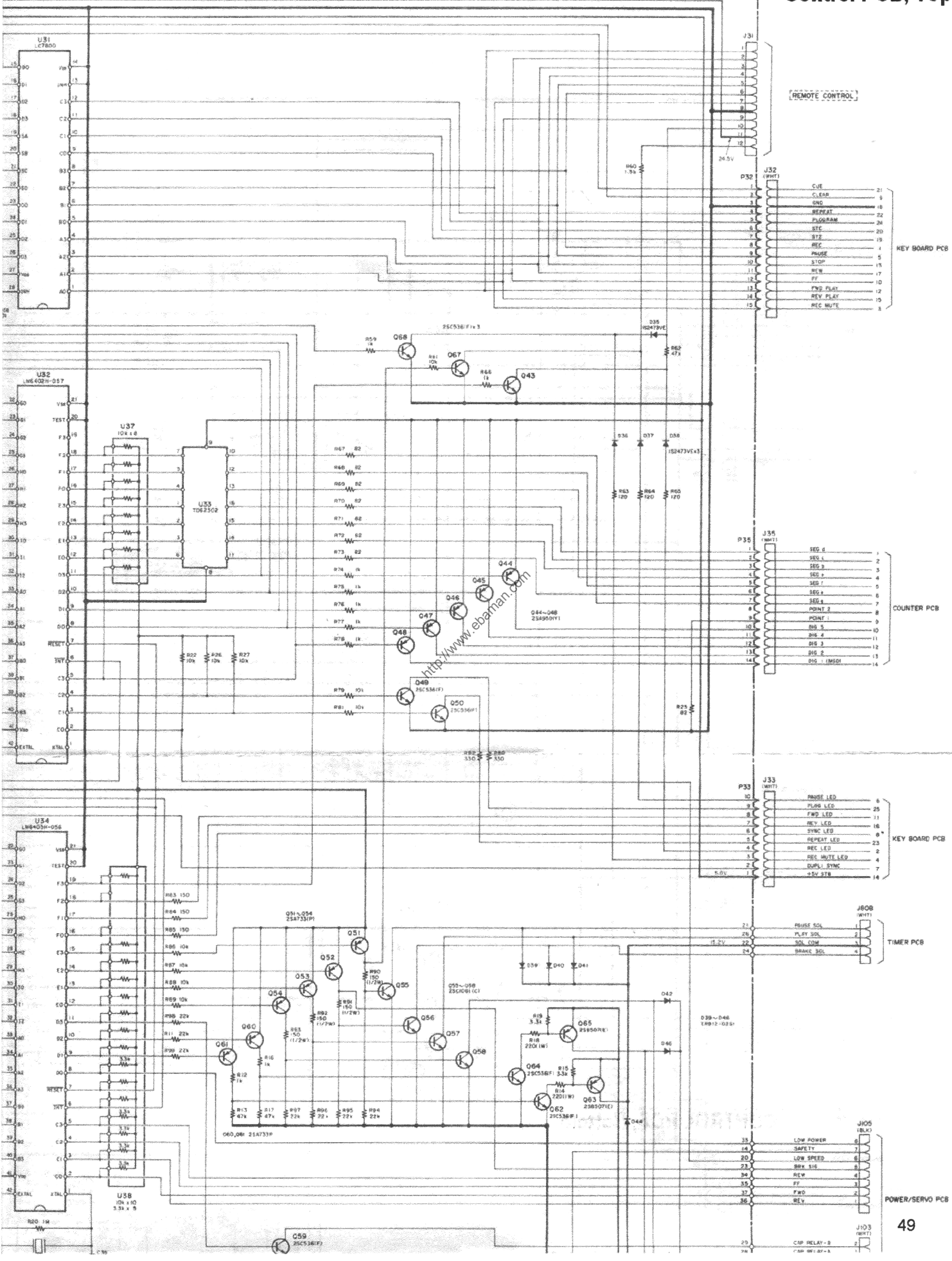

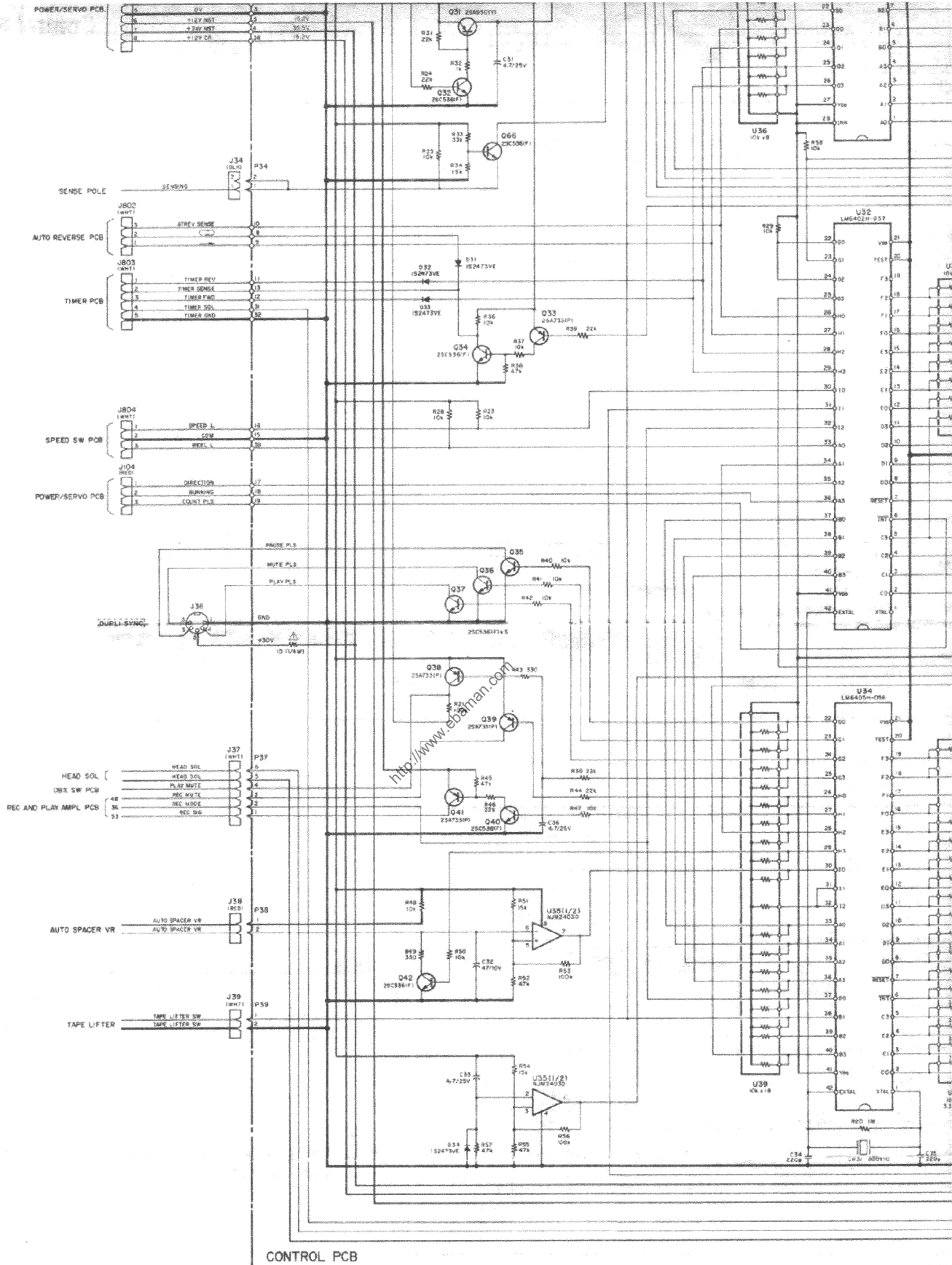

CONTROL PCB, Bottom

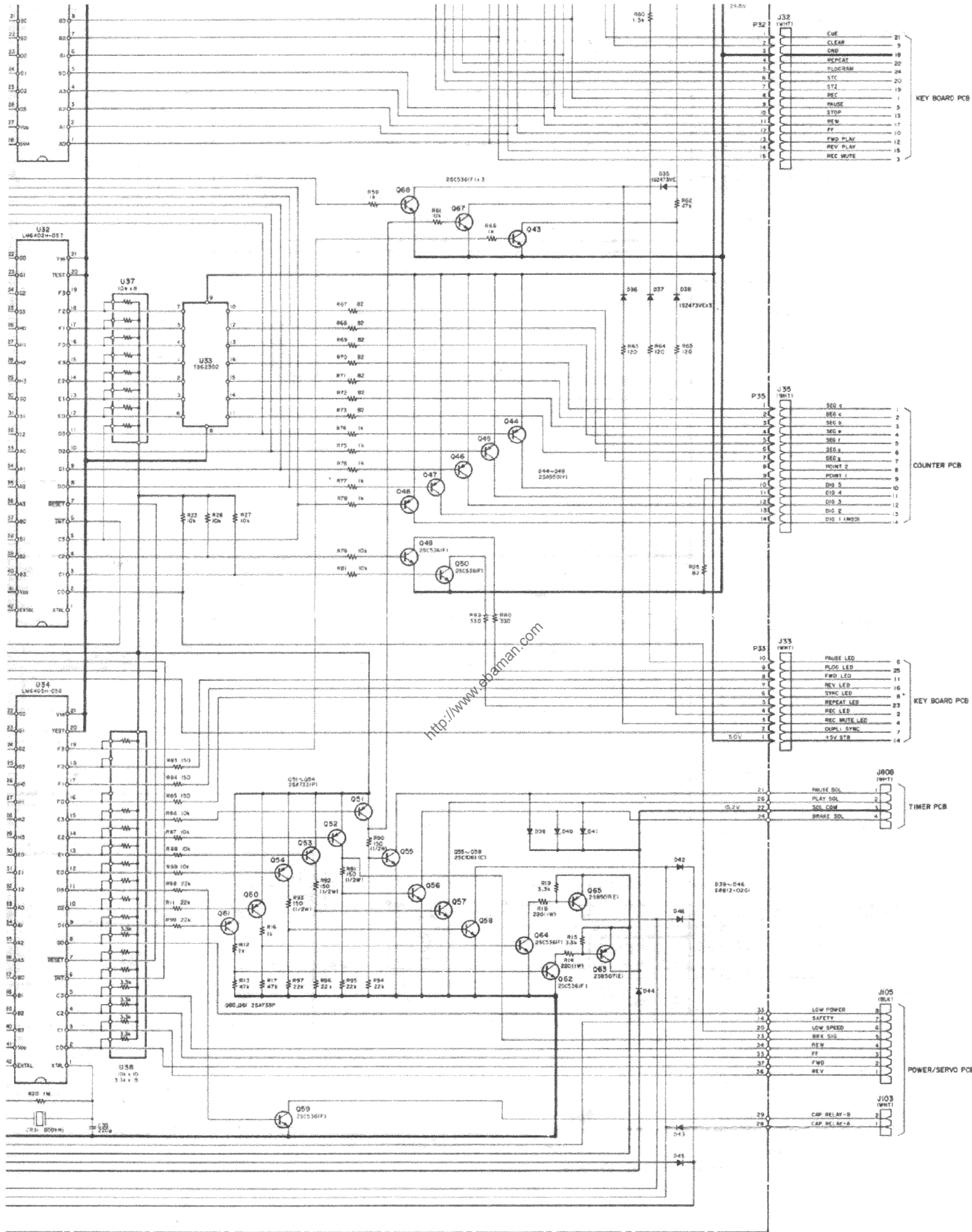

CONTROL PCB, Bottom

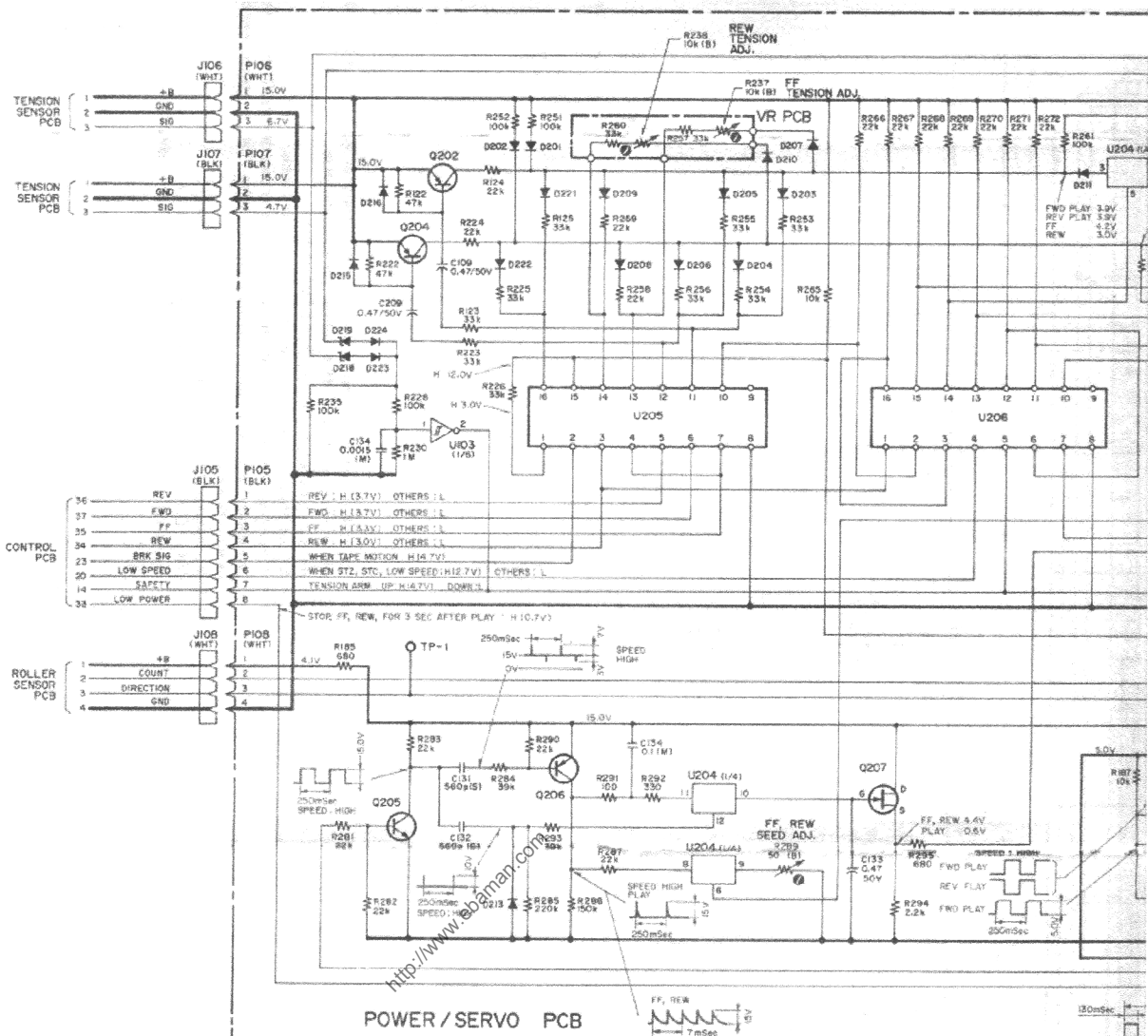

U103	HD14564B	Q102	25C1815 (S)	Q201	25C1815 (GR)	D101 ~ D106	ERB12-02G1	D201 ~ D213	IS2473HJ
U104, U105	HD14011B	Q103	25C636 (F)	Q202	25A1015 (GR)	D108	EQA01-06S	D214	ERB12-02G1
		Q104	25B507 (E)	Q203	25C1815 (GR)	D109, D110	ERB12-02G1	D215, D216	IS2473HJ
		Q105	25C1815 (S)	Q204	25A1015 (GR)			D217	ERB12-02G1
U201 ~ U203	LM2904N	Q106	25B507 (E)	Q205	25C1815 (GR)			D218, D219	WZ90
U204	HD14066B	Q107	25C1815 (S)	Q206	25A1015 (GR)			D220	ERB12-02G1
U205, U206	T062504P	Q108, Q109	25A1015 (GR)	Q207	25K68 (A)			D221 ~ D224	IS2473HJ
		Q156, Q157	25A1015 (GR)						
		Q158, Q159	25C1815 (GR)						

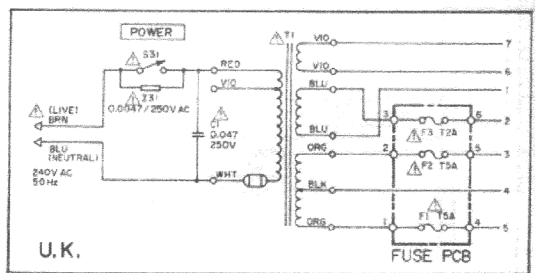
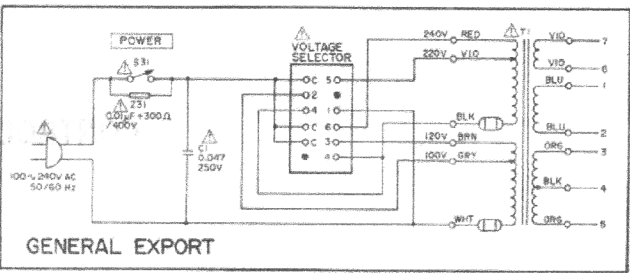
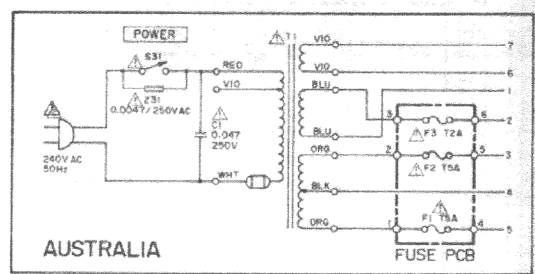
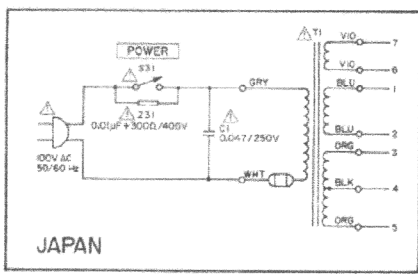
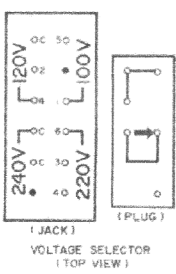

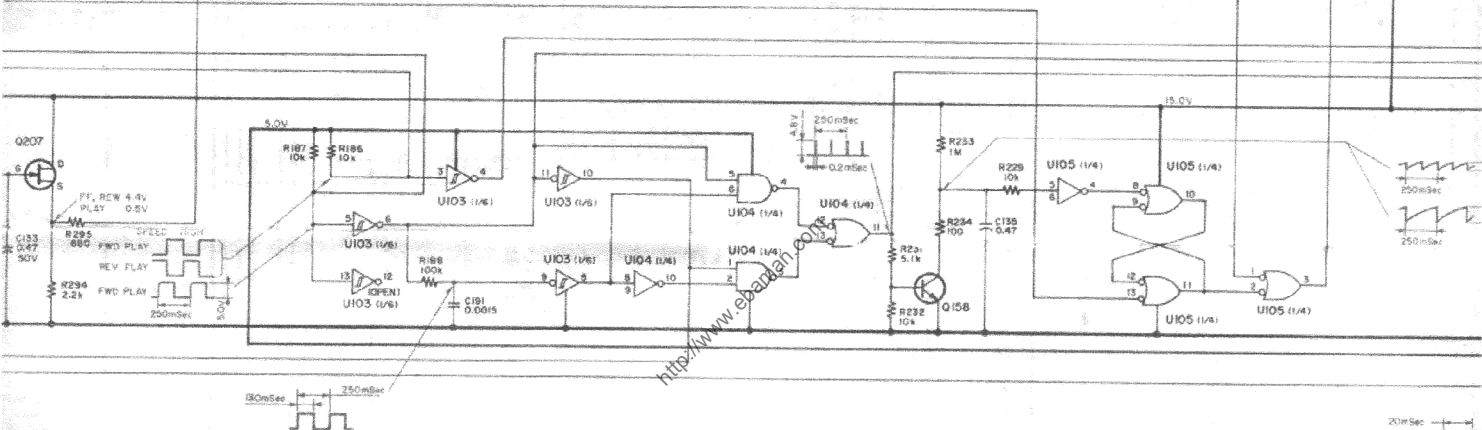
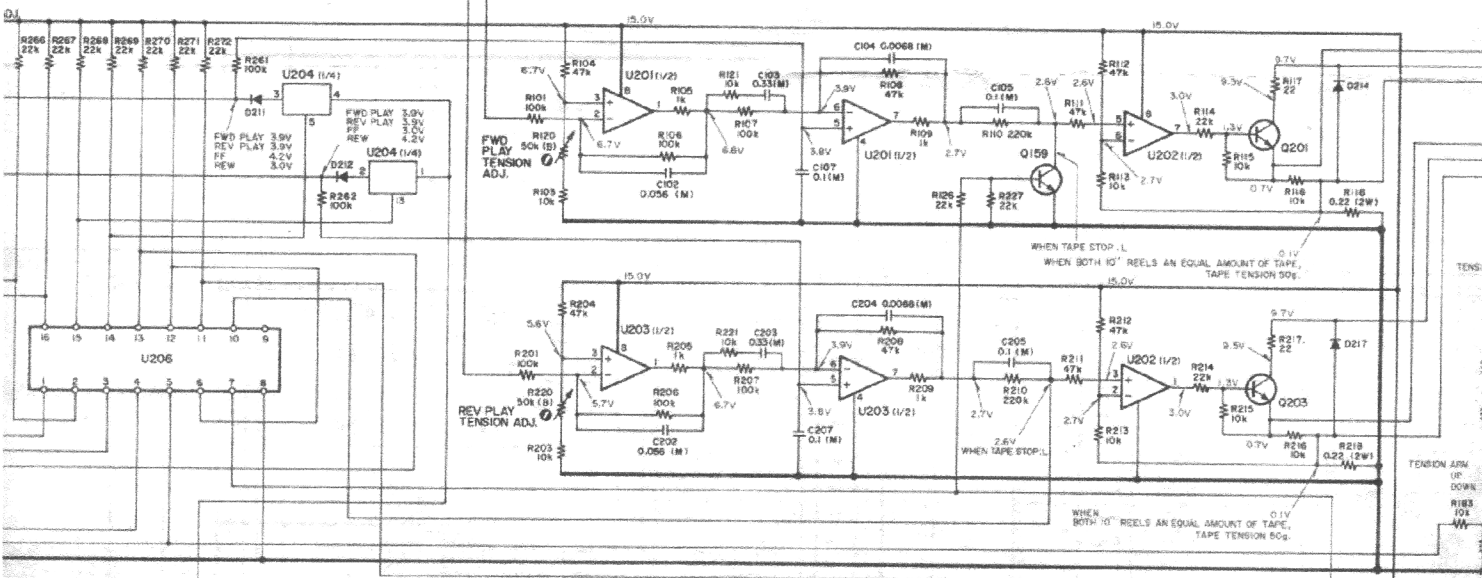

- 6 ERB12-02G1 D201 ~ D213 1S2473HJ
- EQAO1-06S D214 ERB12-02G1
- ERB12-02G1 D215, D216 1S2473HJ
- D217 ERB12-02G1
- D218, D219 W290
- D220 ERB12-02G1
- D221 ~ D224 1S2473HJ

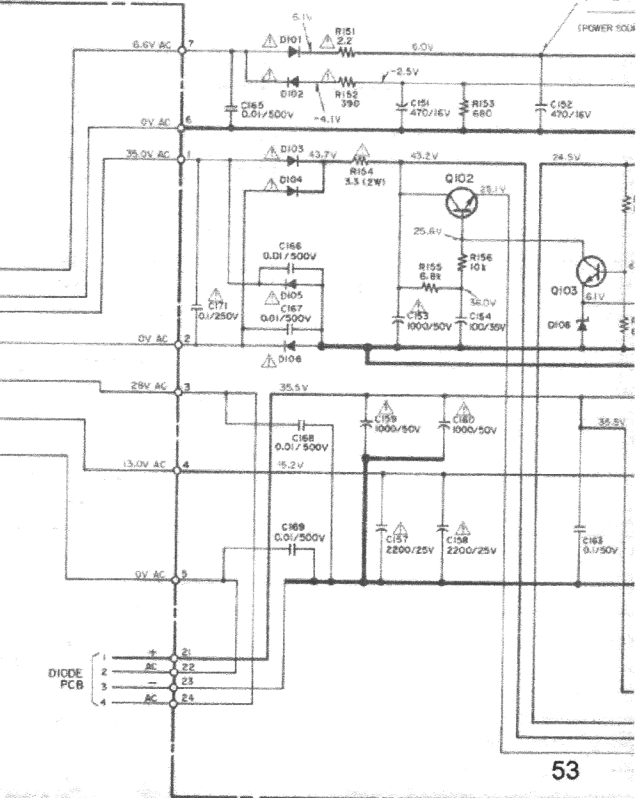
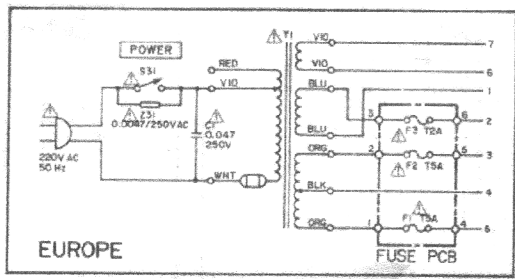
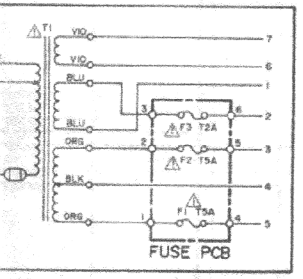
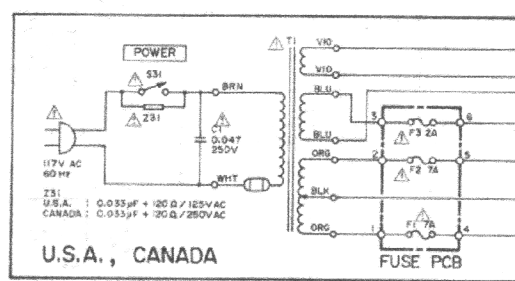
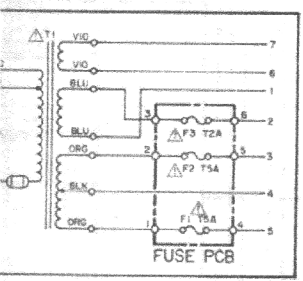

POWER / SERVO PCB

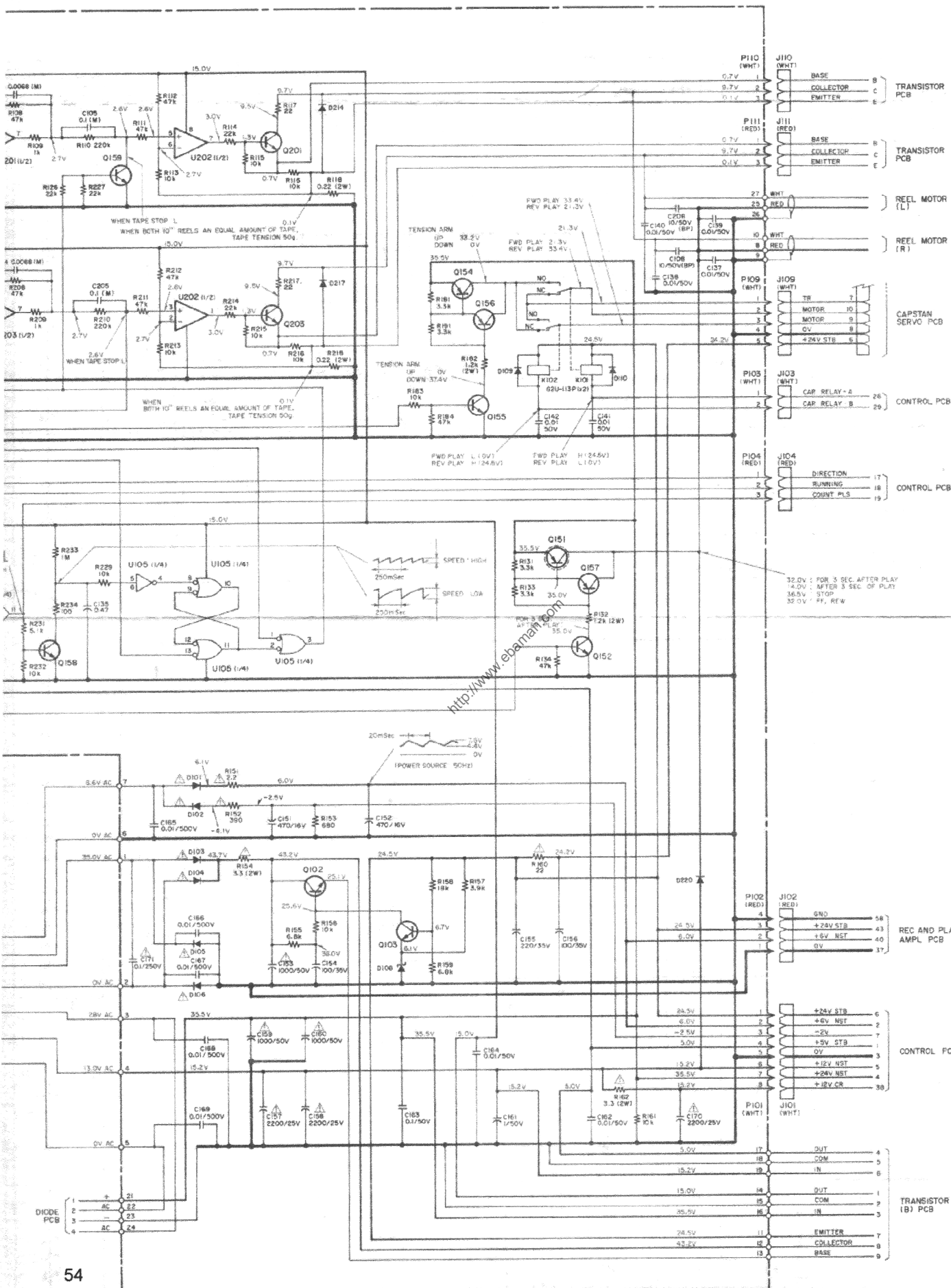

POWER / SERVO PCB

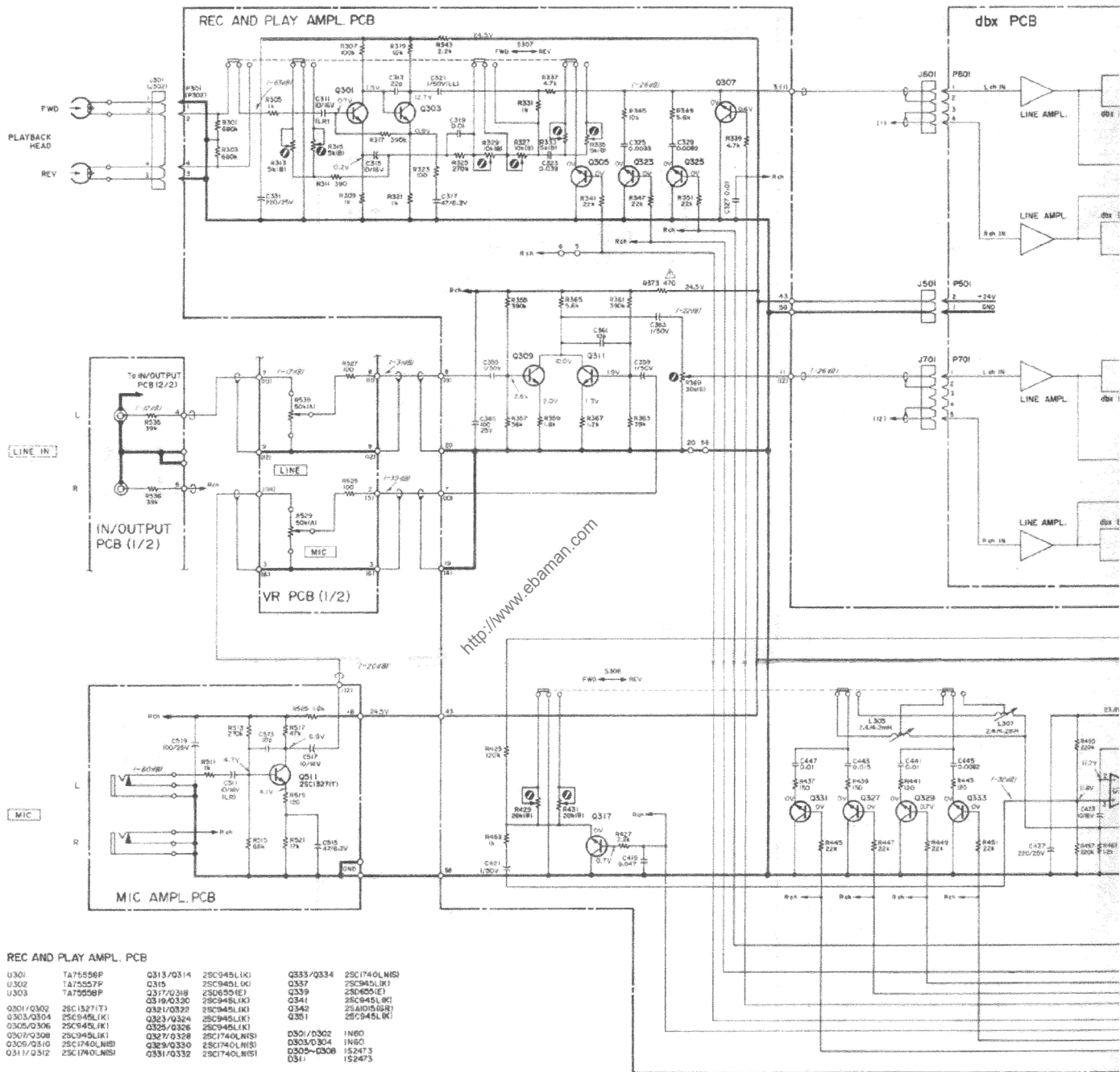

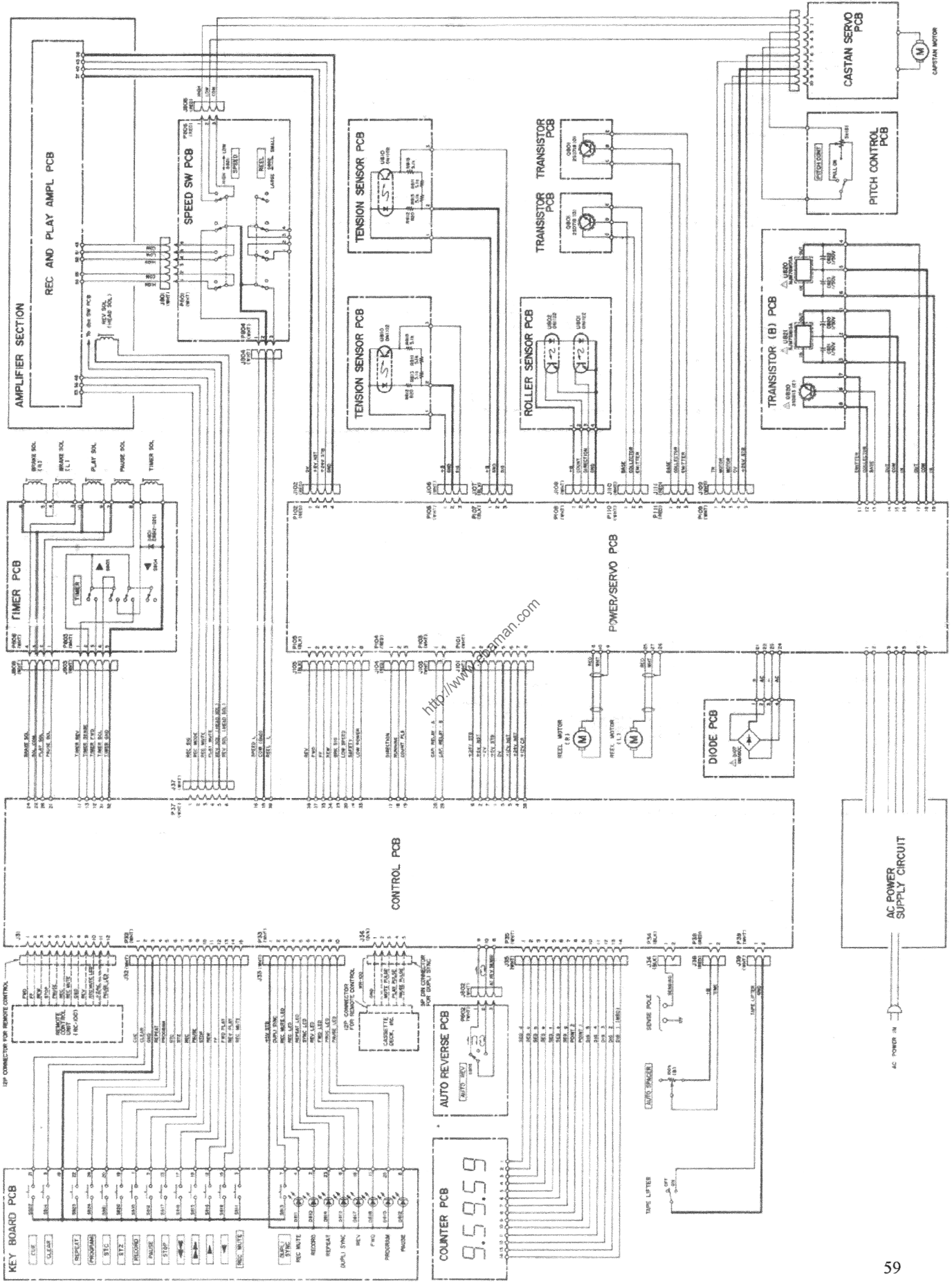

http://www.pearlman.com

COUNTER PCB
9.5.9.5.9

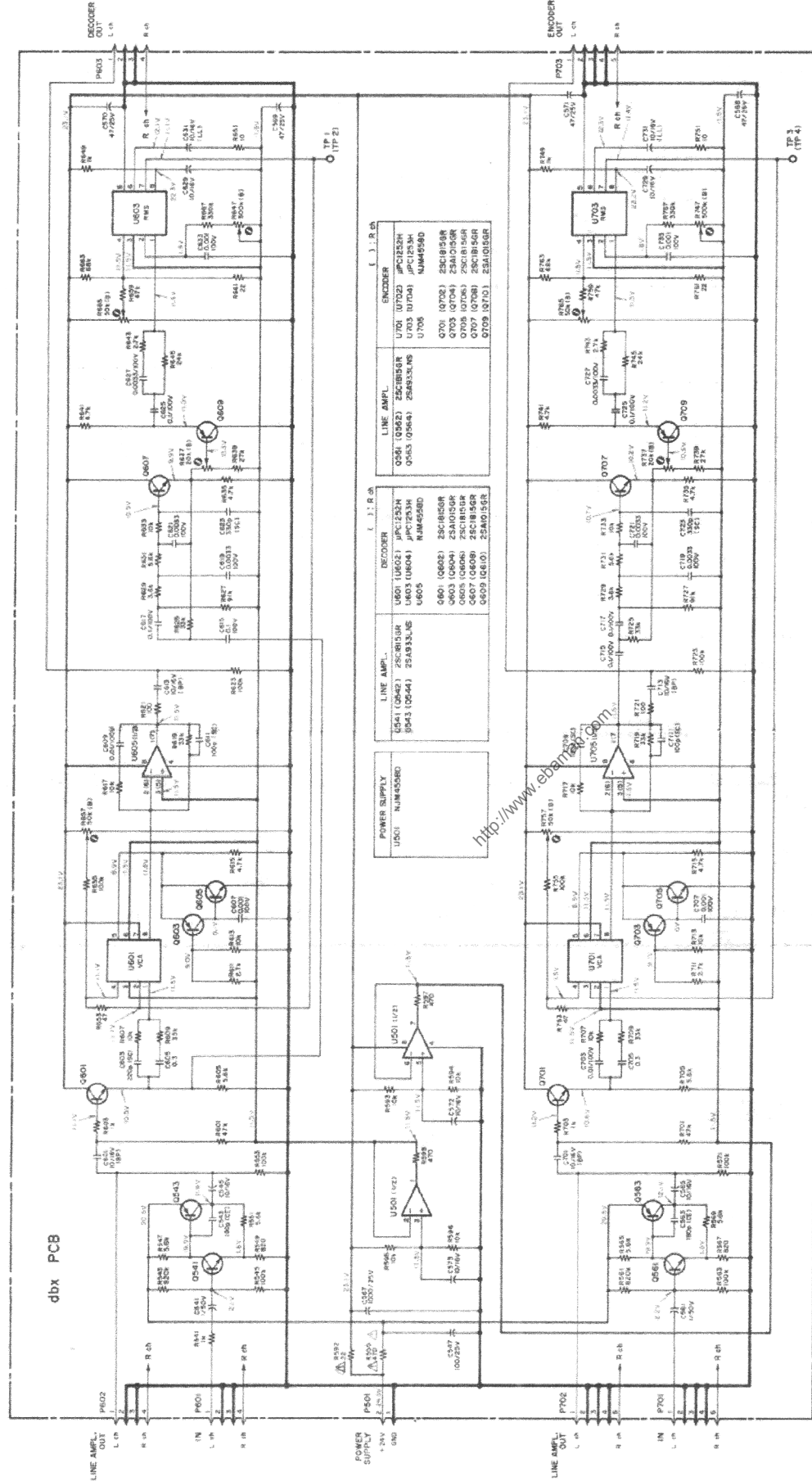

LINE AMPL.	DECODER	ENCODER
U541 (U542) 25C1815SR	U601 (U602) 1PC1233H	U701 (U702) 25C1815SR
U543 (U544) 25A933LS	U603 (U604) 1PC1233H	U703 (U704) 1PC1233H
	U605	U705
		U706
		U707 (U708) 25C1815SR
		U709 (U710) 25A1015SR

NOTES

1. Servo-Amp voltage values are reference values measured in PLAY mode at 19 cm/sec (7 1/2 ips) and are subject to variation according to setting of sensor output.
2. Voltage values, depending on circuit section, may not always conform to indicated values during F.F./REW modes.
3. All resistors are 1/4 watt, ±5%, unless marked otherwise. Resistor values are in ohms (k = 1,000 ohms).
4. All capacitor values are in microfarads (p = picofarads).
5. ⚠ Parts marked with this sign are safety critical components. They must always be replaced with identical components-refer to the TEAC parts list and ensure exact replacement.
6. □ : front panel indication
7. □ : rear panel indication
8. +B : power supply circuit.