

# SERVICE MANUAL

## A-7300/2T

### STEREO TAPE DECK

#### GENERAL DESCRIPTION

TEAC'S A-7300 and A-7300 2T are high quality stereo tape decks, representing a New Generation in the design and construction of recording equipment. With AC reel motors and Direct-Drive Servo-controlled DC Motor-Capstan, all controlled by Integrated Circuit (IC) Logic Circuitry, these decks provide highly reliable operation at greatly reduced noise and heat levels. With almost all relays replaced by Logic Circuits, transport control is quick and positive and governed by 6 calculator-like buttons on the control center. Advanced electronics are also utilized.

This manual is the final version and supersedes previous provisional manual.



# TEAC®

PRODUCT OF JAPAN

51031520

# SPECIFICATIONS

## MECHANICAL

Tracks:	A-7300	4 track 2 channel stereophonic 4 track 2 channel monophonic 4 track 1 channel monophonic
	A-7300 2T	2 track 2 channel stereophonic 2 track 2 channel monophonic 2 track 1 channel monophonic
Heads:		Erase × 1, Rec × 1, Playback × 1
Reel Size:		10-1/2" maximum NAB reel
Tape Speeds:		A-7300.....7-1/2 ips & 3-3/4 ips A-7300 2T..15 ips & 7-1/2 ips
Motors:		Direct drive DC servo capstan motors × 1 6-pole eddy-current induction motors for reel drive × 2
Wow & Flutter:		0.05 % at 15 ips (W-RMS) 0.06 % at 7-1/2 ips (W-RMS) 0.10 % at 3-3/4 ips (W-RMS) Wow and flutter measured according to weighted (W-RMS) NAB standard using TEAC YTT-2004/2003/2002 flutter-free tape. Above value is measured during playback.
Fast Winding Time:		Approx. 150 seconds or less with 1800 ft tape
Power Requirement:		117 V 60 Hz 80 W
Weight:		62 lbs (28 Kg) net
Dimensions:		21-5/8" (H) 17-3/8" (W) 9-3/4" (D) 548 (H)×440 (W)×246 (D) mm

## ELECTRICAL

0 dB = 0.775 V

Frequency Response:	(Measured at 20 dB below the Specified level) Refer to page 11,12,13 Freq. Response Limits chart	
Input Impedance:	LINE: 50 K $\Omega$ or more MIC: 600 $\Omega$ (balanced)	
Output Load Imp:	LINE OUT: 10 K $\Omega$ or more HEADPHONE: 8 $\Omega$	
Equalization: (Playback)	A-7300 7-1/2 ips...50 $\mu$ S & 3180 $\mu$ S 3-3/4 ips...90 $\mu$ S & 3180 $\mu$ S A-7300 2T 15 ips.....50 $\mu$ S & 3180 $\mu$ S 7-1/2 ips...50 $\mu$ S & 3180 $\mu$ S	
Output Level:	OUTPUT: 0 dB +6 dB $\pm$ 1 dB (max.) HEADPHONE: -17 dB -11 dB $\pm$ 2 dB (max.)	
Input Level:	LINE: -8 dB -18 dB $\pm$ 2 dB (min.) MIC: -48 dB -58 dB $\pm$ 2 dB (min.) with ATT (dB) 0 (back panel) -38 dB $\pm$ 3 dB (min.) with ATT (dB) 20 (Back panel)	
Bias Frequency:	100 KHz ( $\pm$ 5 KHz: Push-pull Oscillator)	
Crosstalk Rejection:	40 dB or more, adjacent track at 1 KHz	
Channel Separation:	45 dB (4T, 2T) or more, channel to channel at 1 KHz	
Erasure:	68 dB (4T), 65 dB (2T) or more	
Signal-To-Noise Ratio: (playback)	Better than 53 dB at 15 ips Better than 52 dB at 7-1/2 ips Better than 48 dB at 3-3 4 ips	

# TAPE TRANSPORT PARTS LOCATION

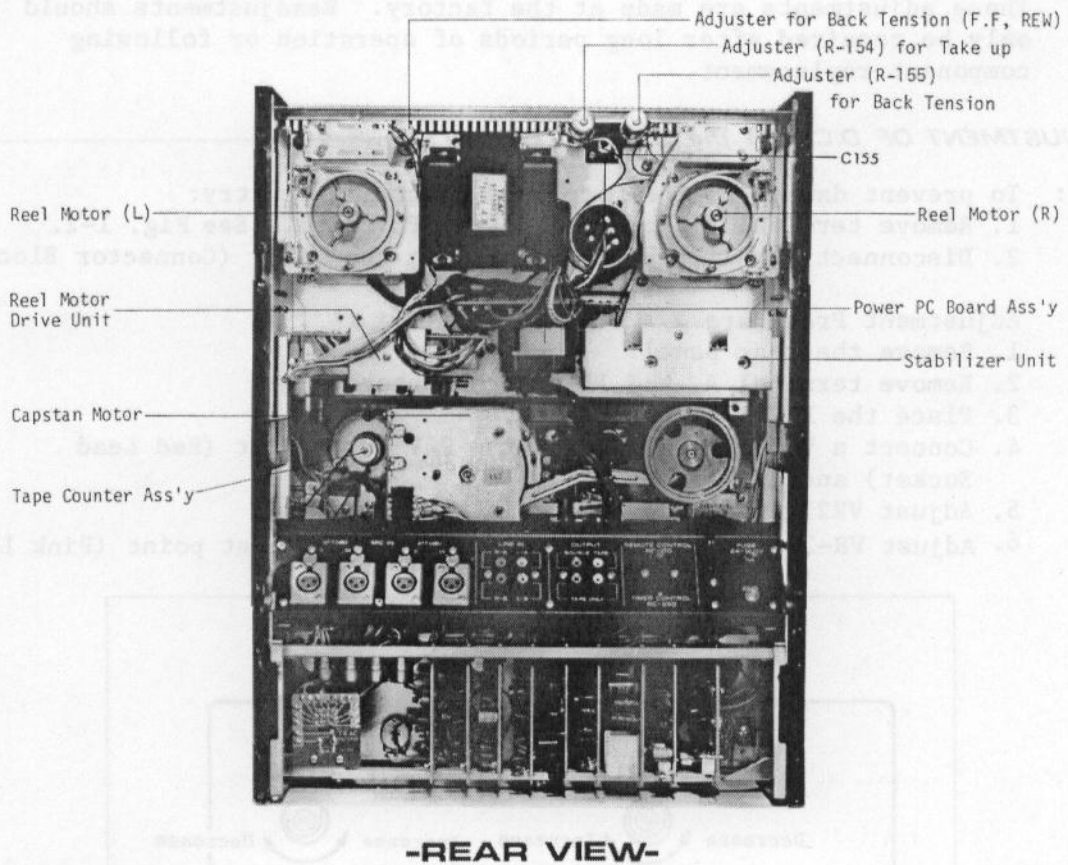

Fig. 1-1 Tape Transport Parts Location

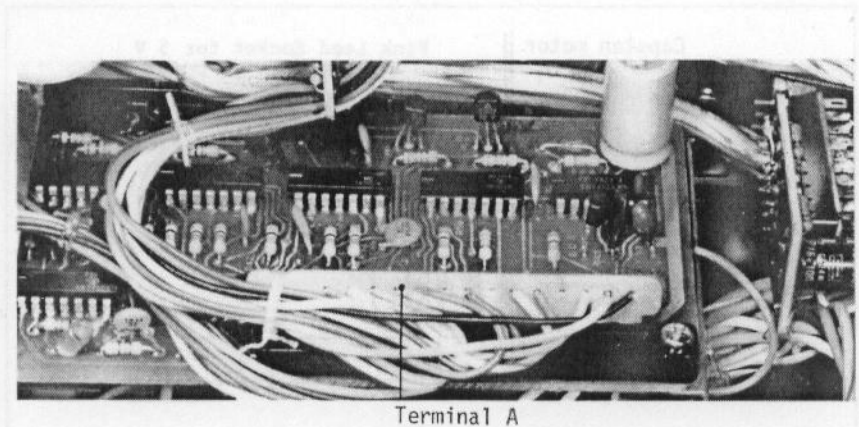

Fig. 1-2 Control PC Board

## MEASUREMENT AND ADJUSTMENT -MECHANICAL-

The TEAC A-7300 uses highly reliable AC Motors for both reel motors, and a DC direct-drive capstan system. It should require a minimum of mechanical maintenance or adjustment. These adjustments are made at the factory. Readjustments should only be required after long periods of operation or following component replacement.

### ADJUSTMENT OF D.C. (on the STABILIZER UNIT)

NOTE : To prevent damage to the motor and control circuitry:

1. Remove terminal A from the Control PC board. See Fig. 1-2.
2. Disconnect the 11 pin connector from the motor (Connector Block).

#### Adjustment Procedure

1. Remove the rear panel.
2. Remove terminal A, and 11 pin connector.
3. Place the POWER switch to "ON".
4. Connect a VOM or VTVM across the 24V Test Point (Red Lead Socket) and chassis Ground.
5. Adjust VR21 if needed to obtain  $24V \pm 0.5V$  DC.
6. Adjust VR-22 for  $5V \pm 0.25V$  DC output at 5V test point (Pink Lead socket).

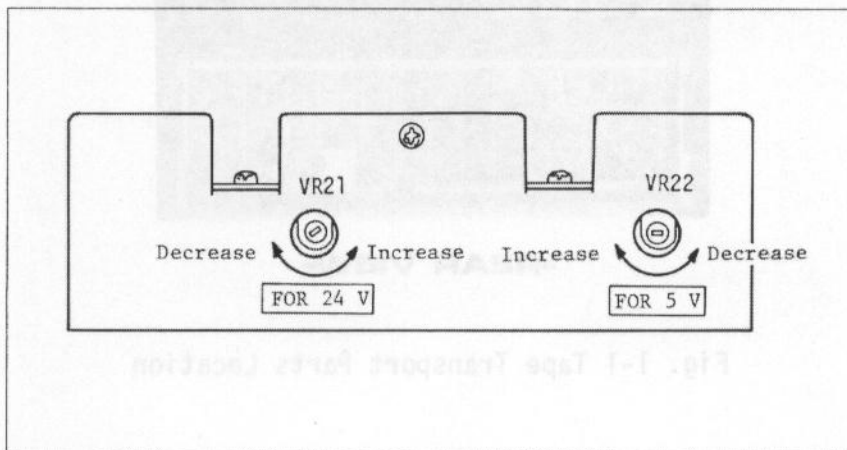

Fig. 2 Adjustment Locations

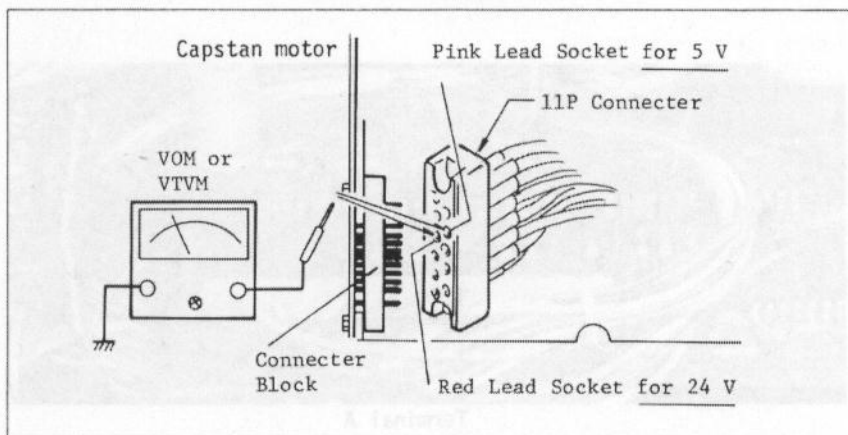

Fig. 3 Test Points

## CAPSTAN SHAFT TOLERANCE ADJUSTMENT

1. Check that the capstan motor moves freely without binding on the Thrustplate.
2. Check that the clearance between the motor shaft tip and the Thrustplate is between 0.1 and 0.3 millimeter.
3. To adjust, first loosen the locking nut; then set with a common screwdriver for approx. 0.2mm clearance. Check by observing the capstan movement.
4. Tighten the Lock Nut and secure with locking paint.

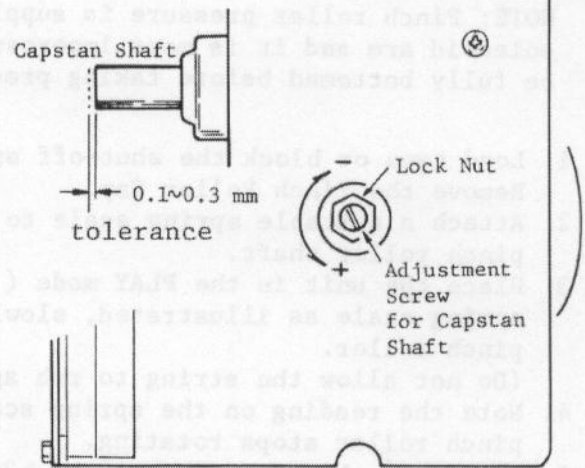

Fig. 4 Shaft Tolerance Adj. Location

## TAPE SPEED ADJUSTMENT

Place the PITCH CONT to the OFF position. The tape speed should be measured using TEAC flutter free tape, Model YTT-2004 (15 ips), YTT-2003 (7-1/2 ips), YTT-2002 (3-3/4 ips).

These tapes contain a highly accurate 3000 Hz tone. Connect a digital frequency counter to either line OUTPUT jack.

The indicated frequency should be 3000 Hz ( $\pm 10$  Hz or less) for both speeds. If necessary, adjust "adjustable resistors" on the CAPSTAN MOTOR.

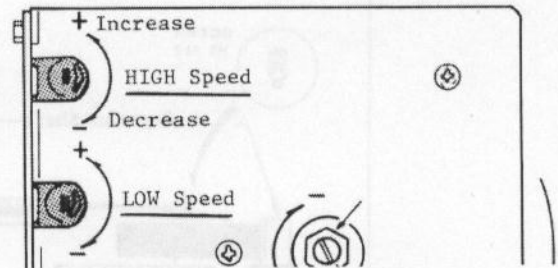

Fig. 5 Tape Speed Adjusters

## FLUTTER

Flutter should be measured in Playback mode using a TEAC flutter-free tape YTT-2004 (15ips), YTT-2003 (7-1/2ips), 2002 (3-3/4ips) and Meguro model MK665B flutter meter. Measurement of flutter should be made accordance with NAB standards. Values obtained with different standards of equipment cannot be compared.

Flutter should not exceed.	15ips	: 0.10% (RMS)	0.05% (W-RMS)
	7-1/2ips:	0.12% (RMS)	0.06% (W-RMS)
	3-3/4ips:	0.15% (RMS)	0.10% (W-RMS)

These figures apply to any tape position and direction (such as full take-up reel, full supply reel or about mid-point). If there is excessive wow and flutter, examine the pinch roller, motors, capstan shaft, and reel rest for "grease", "oil", "dirt" and/or "wear". Also examine the tape counter assy for evenness of operation.

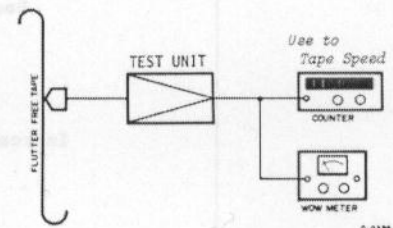

Test Equipment Set-up

## PINCH ROLLER PRESSURE

NOTE: Pinch roller pressure is supplied by the pinch roller solenoid arm and it is most important that the solenoid plungers be fully bottomed before taking pressure measurement.

1. Load tape or block the shut-off arm in the "ON" position. Remove the Pinch Roller Cap.
2. Attach a suitable spring scale to a screw inserted in the pinch roller shaft.
3. Place the unit in the PLAY mode (▶), and holding the spring scale as illustrated, slowly draw it away from the pinch roller.  
(Do not allow the string to rub against the pinch roller.)
4. Note the reading on the spring scale at the instant the pinch roller stops rotating.
5. The scale should indicate  $2 \text{ kg} \pm 200 \text{ g}$  for 2T ( $1.8 \text{ kg} \pm 200 \text{ g}$  for 4T).
6. If adjustment is necessary, loosen the 3 mounting screws on the capstan solenoids and position the solenoids for optimum pressure.

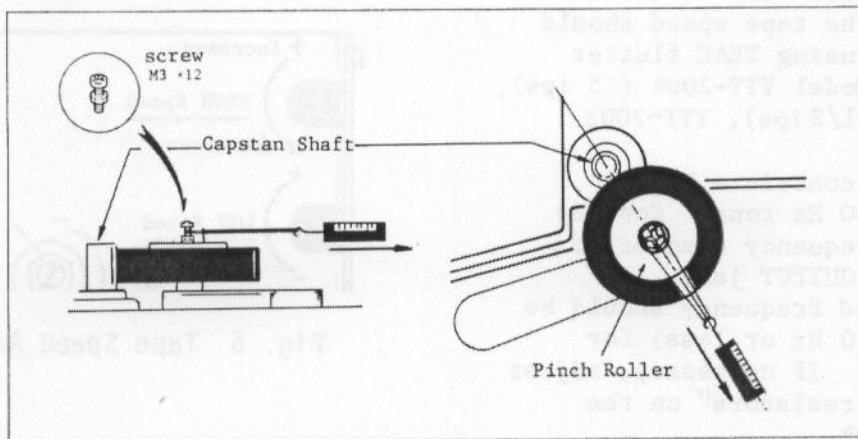

Fig. 6 Pressure Measurement

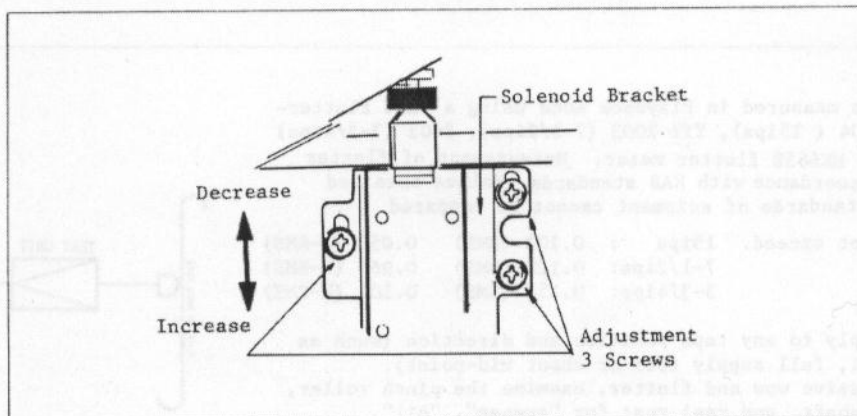

Fig. 7 Adjustment Location

## TORQUE MEASUREMENT PROCEDURE

All Torque and Tension Measurement must be made with the automatic shut-off switch (right tension arm) blocked to the "ON" position.

### BACK TENSION:

1. Place the REEL size switch to the LARGE position.
2. Block the shut-off arm in the "ON" position.
3. Install an empty 7" reel (TEAC RE-702) on the left reel table.
4. Rotate the reel and wind several turns of string counter-clockwise around the hub. Attach spring scale to string.
5. Place the unit in the (▶) play mode.
6. Pull the scale away from the reel against the motor torque with a steady smooth motion.
7. Note the scale reading while it is in steady motion.  
(The string must not rub the reel flanges.)
8. Adjust R-155 as needed to obtain tension of  $450 \pm 20$  (g-cm).  
(calculated value using  $T = R \times W$ )
9. Repeat all the above for the REEL-SMALL position.  
Reading should be 300 (g-cm).

### TAKE-UP TORQUE:

1. Place the REEL size switch to the LARGE position, with empty reel and attached spring scale on the right reel table.
2. Place the unit in the (▶) play mode.
3. Allow the rotation of the reel to slowly draw the scale toward the hub.
4. Hold the spring scale with enough force to allow a steady reading.
5. It should be approx.  $550 \pm 20$  (g-cm).  
If adjustment is necessary, slide the band on R-154. (The same resistor is also used for SMALL REELS).

### NOTE

To measure torque when using a reel with a hub radius of other than 3.0cm refer to following table;

### FORMULA FOR TORQUE CALCULATION:

$$T \text{ (g-cm)} = R \times W$$

R: radius of hub (cm)  
W: gram

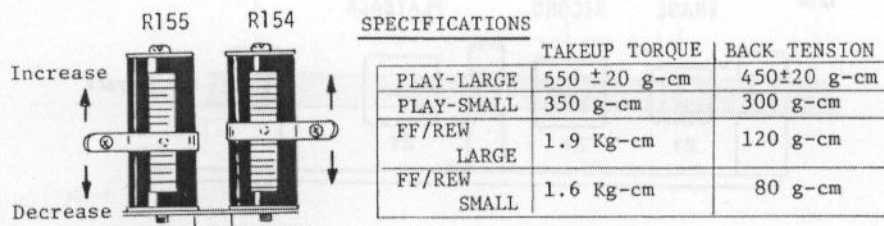

Fig. 8 Torque Adj. Location

# HEAD ALIGNMENT

HEAD ASSEMBLY (head cluster) is adjusted to very close tolerance at the factory and normally requires only minor alignments or adjustments after replacement on the deck. Complete readjustment of the HEAD ASSEMBLY will be necessary when an individual head is replaced.

## HEIGHT ADJUSTMENT (4 track)

**RECORD HEAD:** The record head pole should be above the edge of a threaded tape by the width of a thin pencil line.

**PLAYBACK HEAD:** The forward playback head pole should be even with the top of a threaded tape.

**PLAYBACK HEAD:** The pole of the reverse head should be even with the bottom of a threaded tape.

**ERASE HEAD:** Erase section should be a heavy pencil line above.

### NOTE

A-7300 2 track RECORD and ERASE heads are centered on the tape. PLAYBACK head forward section is a heavy pencil line above the edge. Refer to the illustration below.

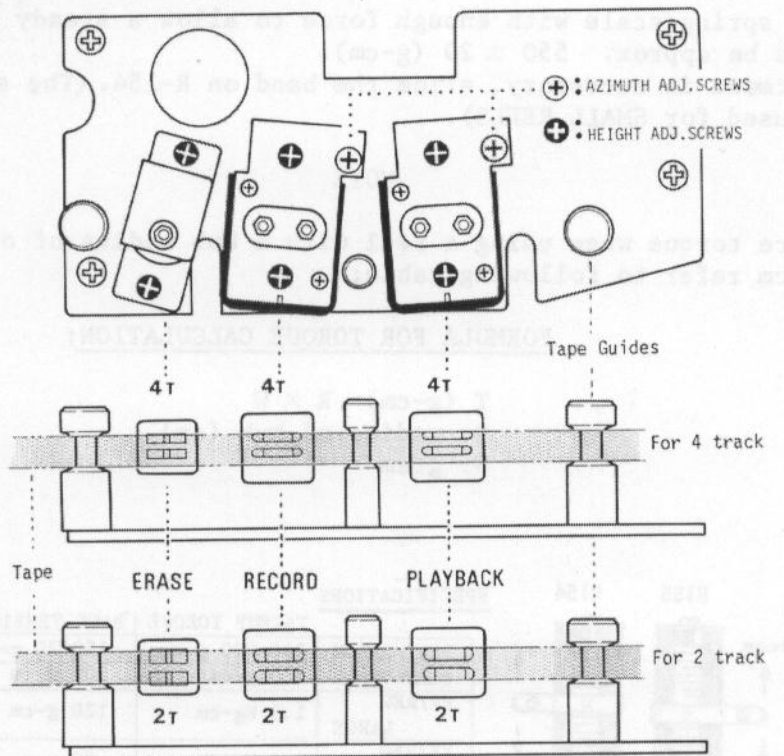

Fig. 9 Head Configuration and Alignment Screws



## HEAD ASSEMBLY REMOVAL AND REPLACEMENT

1. Remove power from the unit.
2. Move head assembly cover by removing 2 screws on the left and right end of the head cover and then gently move cover toward the top of the deck.
3. Remove 4 mounting screws from the head assembly.
4. Lift head assembly and remove the 2 pin jacks and the 9 pin connector mounted on the rear of the head housing.
5. Lift off head assembly.
6. Loosen 2 counter-sunk screws (A) from the rear plate of the head assembly and remove 2 small screws (B) from the top of the head. Then slide off the shield case (C).
7. To replace a single head, a nut driver is required. Remove the 2 nuts (D) on the defective head through the access hole provided. This releases the head from the mounting plate.

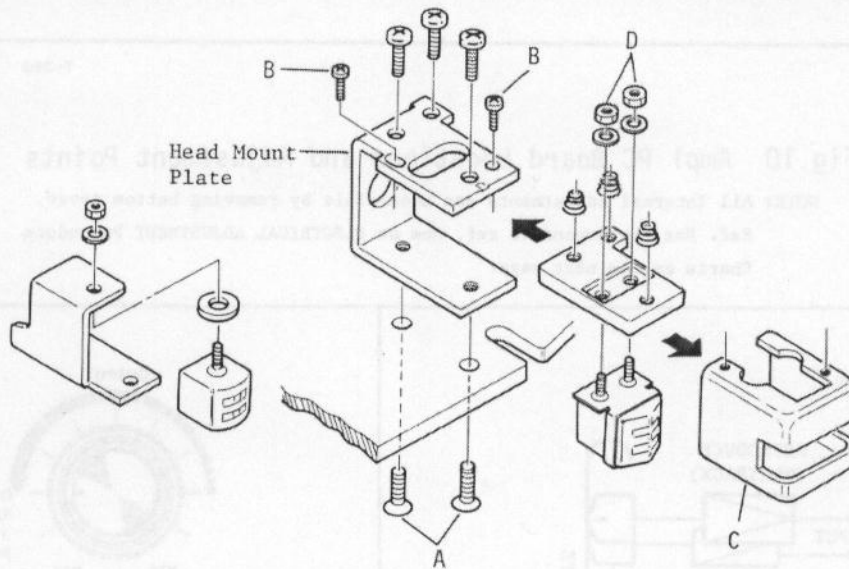

Fig. 10 Head Replacement

After the head is replaced be sure to replace the shield case and tighten the 2 counter-sunk screws on the rear of the head assembly plate. Also insure that the spring on the head assembly cover is properly set in the slot on the head cover bracket. (Ref. to Parts List).

### -FEATURE COMPARISON CHART-

	A-7300	A-7300 2T
Heads	4T 2 ch	2T 2ch
Speed	7-1/2, 3-3/4 ips	15, 7-1/2 ips
Special Features	Uniform Wind	Edit function
	Index counter	Linear Counter
	No memory Rewind	Memory Rewind

# ADJUSTMENT LOCATIONS

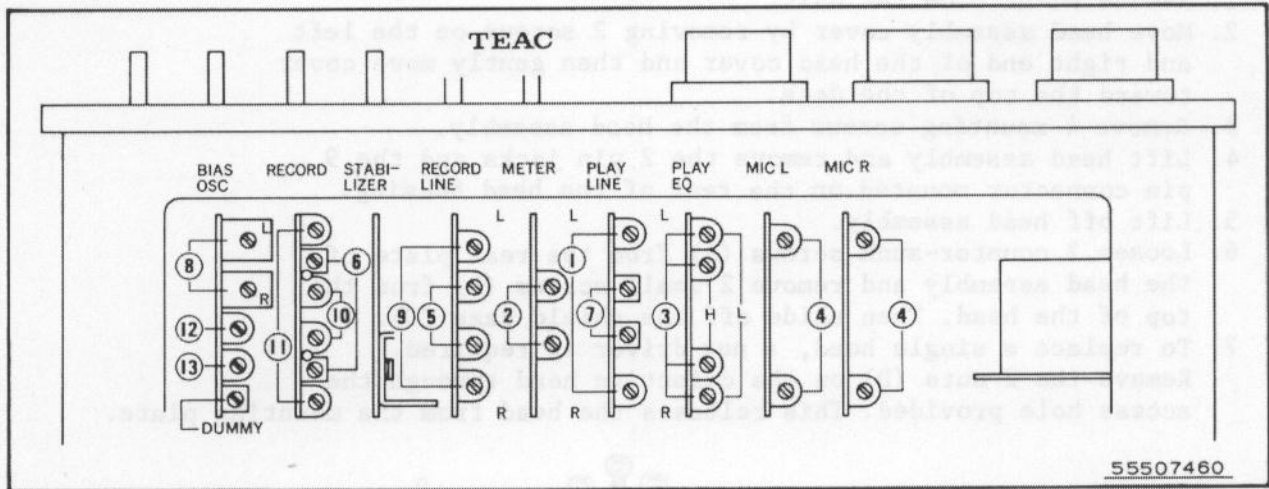

T-340

Fig.10 Ampl PC Board Locations and Adjustment Points

NOTE: All Internal adjustments are accessible by removing bottom cover.  
 Ref. Nos correspond to ref. Nos on ELECTRICAL ADJUSTMENT Procedure Charts on the next page.

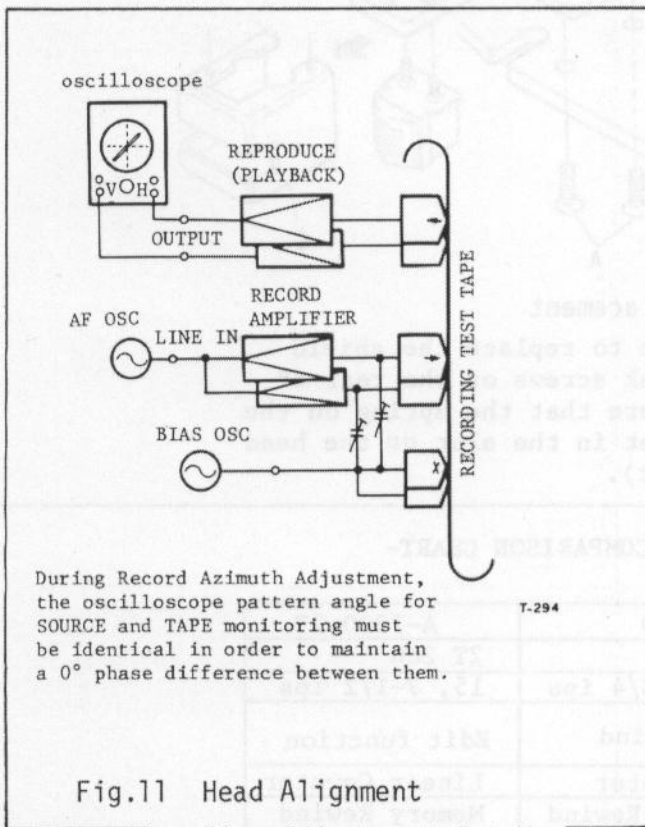

Fig.11 Head Alignment  
 Fine Adjustment Set-Up

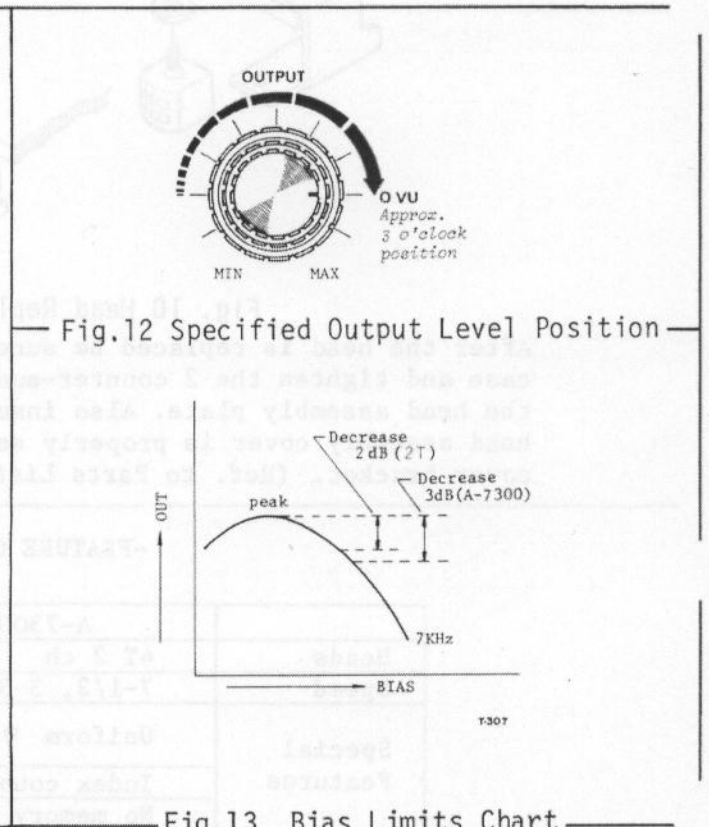

Fig.12 Specified Output Level Position

Fig.13 Bias Limits Chart

## ELECTRICAL ADJUSTMENTS

Ref. Nos.	ITEM	SIGNAL SOURCE	MEASUREMENT CONNECTION	MODE	ADJUSTING POINT (on P.C.B.)	INSTRUCTIONS
	Playback Head Adjustment	TEAC Test Tape YTT-1003 15KHz Test Tone	VTVM & Oscilloscope to OUTPUT jacks	TAPE (playback)	Play Azimuth Screw on Head Assy'	1. Tape SPEED at LOW. 2. Adjust for maximum indication. 3. Less than 45° out of phase at oscilloscope.
①	Specified Output Level Setting	400 Hz 0 dB Test Tone	VTVM to OUTPUT jack	TAPE	VR-251 VR-252 on Play Line	1. OUTPUT control at the 0 VU position 2. Adjust for 0 dB at OUTPUT jack. (This is the specified output level.)
②	VU meter Calibration				VR-301 VR-302 on Meter	1. METER switch to NORMAL for 0 VU, HIGH for $-3 \pm 0.5$ VU Reading on the VU meter lower scale.
③	Frequency Response	TEAC Test Tape YTT-1004 YTT-1003			VR-203 (HIGH) VR-204 on Play Eq  VR-201 (LOW) VR-202 on Play Eq	1. Compare the readings obtained on the VTVM with response Limits given in Fig. 14
④	Monitor Level Setting	400 Hz -18 dB (97mV)	AF Oscillator to LINE IN jacks	SOURCE	VR-401 VR-402 on Mic L, R	1. Adjust to obtain the specified output level of 0 dB at OUTPUT jacks. 2. input selector → LINE
⑤	VU meter Level Set	400 Hz 0 dB (775mV)			VR-451 VR-452 on Record Line	1. METER switch in NORMAL. 2. Adjust to obtain 0 VU on the VU meter.
	Record Head Azimuth Adjustment	AF Oscillator to the LINE IN jack 10KHz -28dB (31mV)	Oscilloscope to OUTPUT jack	SOURCE & TAPE	Record Azimuth Screw on Head Assy'	RECORD MODE → ON 1. Move the MONITOR switch to the TAPE position. 2. Adjust for maximum indication. 3. Both channels on the Oscilloscope to be in Phase.
⑥	Bias Trap Adjustment	No signal	VTVM or Oscilloscope across the Test Point & ground (on the REC P.C.B.)	SOURCE	L-503 L-504 on Record	1. Depress REC and "PAUSE" buttons. 2. Using TEAC Test Tape YTT-8013. 3. BIAS switch to #1 4. RECORD MODE → ON 5. Adjust for minimum.
⑦					L-251 L-252 on Play Line	5. Adjust L-251/252 for minimum bias leakage reading at OUTPUT jacks Spec. -45 dB or less.
⑧	Bias # 1 Adjustment	7 KHz -18 dB (97mV)	VTVM to OUTPUT jack	TAPE	VC-551 VC-552 on Bias Osc	1. Using TEAC Test Tape YTT-8013. 2. BIAS/EQ switch to #1. 3. Adjust clockwise a decrease 2 dB from the peak. See Fig.13
⑨	Record Level Set	400 Hz -8 dB (308mV)			VR-453 VR-454 on Record Line	1. Using TEAC Test Tape YTT-8013. 2. BIAS/EQ switch to #1. 3. Adjust for 0 dB at OUTPUT jack.
⑩	Overall Frequency Response	30 Hz to 28 KHz			VR-503 (HIGH) VR-504 on Record	1. BIAS/EQ switch to #1. 2. Using TEAC Test Tape YTT-8013. 3. Adjust for each channel
⑪	at -28dB (31mV)	40 Hz to 24 KHz			VR-502 (LOW) VR-501 on Record	1. Place the SPEED switch to LOW. 2. Adjust for each channel
⑫	Bias # 2 Adjustment	30 Hz to 24 KHz			VR-552 on Bias Osc	1. BIAS/EQ switch to #2. 2. Using TEAC Test Tape YTT-8003; Adjusts both channels together.
⑬	Bias # 3 Adjustment	30 Hz to 24 KHz			VR-551 on Bias Osc	1. BIAS/EQ switch to #3. 2. Using TEAC Test Tape YTT-8023; Adjusts both channels together. 3. Repeat Overall response check at LOW, both speeds refer to response Limits given in Fig. 15,16

If the TEAC YTT-series blank test tapes ( 8013,8003,8023 ) are not available use any of the tapes listed on page 12 that require the same EQ switch and BIAS switch settings.

# FREQUENCY RESPONSE CHART 2T.4T

## PLAYBACK PERFORMANCE (2T,4T)

1. Play Test Tape that matches the speed of your deck:

15 ips 2T.....YTT-1004  
 7-1/2 ips 2T, 4T...YTT-1003  
 3-3/4 ips 4T.....YTT-1002

2. Set output controls to specified level. Compare output reading to following charts.

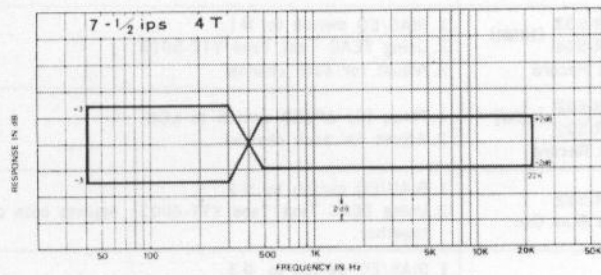
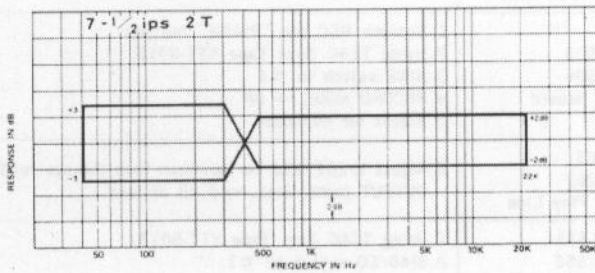
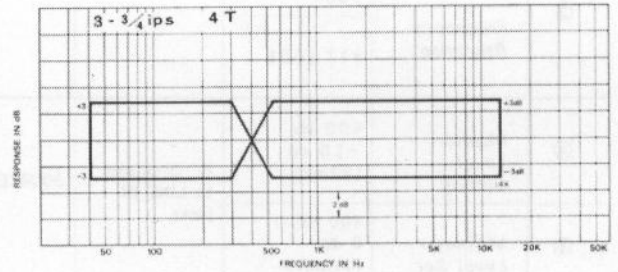
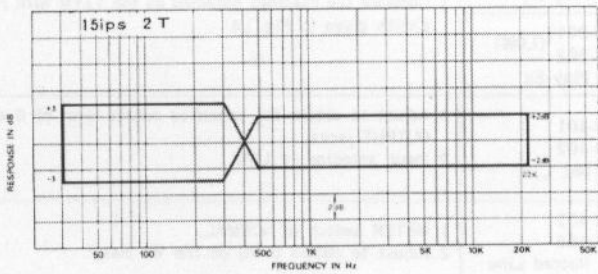

Fig.14 Frequency Response Limits  
 - Playback -

# FREQUENCY RESPONSE CHART 2T

## RECORD PERFORMANCE (2T,4T)

1. Measured with input 20 dB below the Specified input level.
2. Level should correspond to charts below (per Speed employed).
3. Set BIAS, EQ switches to match the Tape you are using per the chart below:

BIAS, EQ #1 YTT-8013  
 BIAS, EQ #2 YTT-8003  
 BIAS, EQ #3 YTT-8023

4. Repeat Frequency Response check for all speeds.

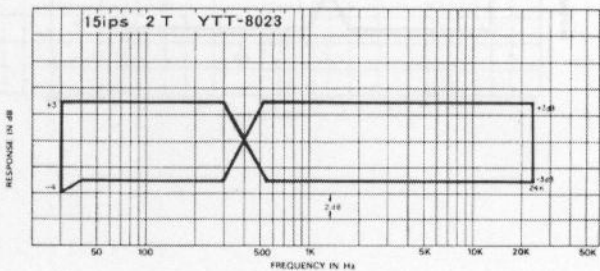
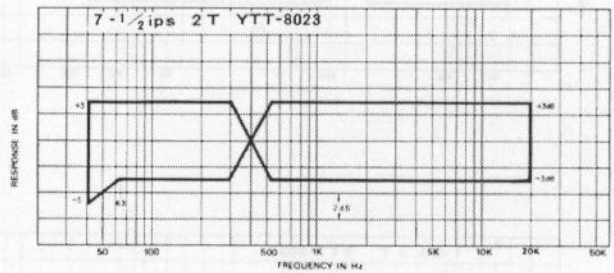
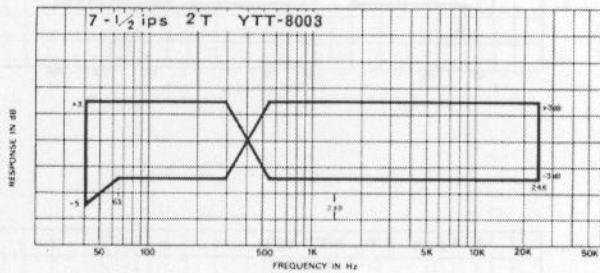
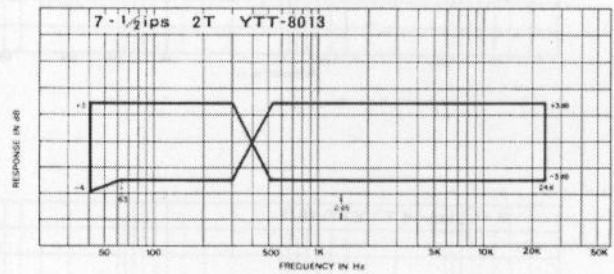
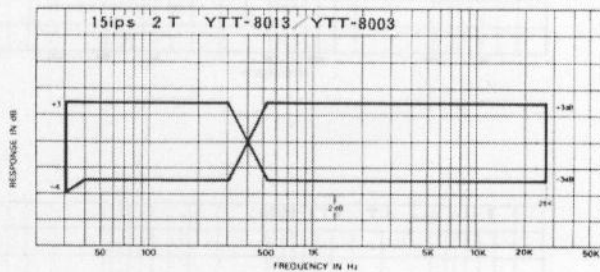

Fig.15 Frequency Response Limits  
 - Record -

Cont' on next page.....

### Recommended BIAS and EQ switch settings for various types of tape

1 mil base tape (recommended for 2-track or 4-track decks)				1-1/2 mil base tape (recommended for 2-track decks only)			
Brand	Type or model	BIAS	EQ	Brand	Type or model	BIAS	EQ
MAXELL	UD-35	1	1	MAXELL	UD-50	1	1
FUJI-FILM	FG-150	1	1	SONY	SHL-11-740B	1	1
SONY	SHL series	1	1	SCOTCH	211	1	1
TDK	AUDUA series	1	1	BASF	SPR-50LH	2	2
FUJI-FILM	FB-151	2	2	MEMOREX	1200	2	2
BASF	LRP or LP-35LH	2	2	FUJI FILM	FB-101	2	2
MEMOREX	1800	2	2	SCOTCH	111 or its Equivalent	3	3
FUJI-FILM	FM-150						
SCOTCH	150 or its equivalent	3	3				

# FREQUENCY RESPONSE CHART 4T

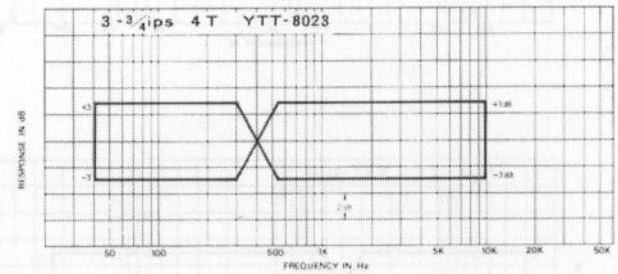
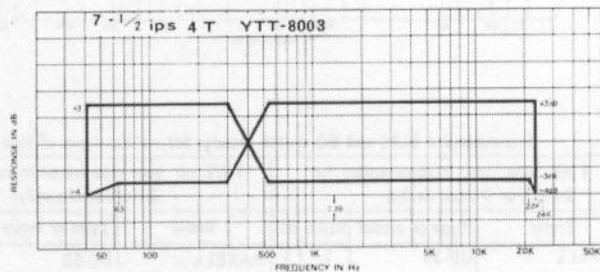
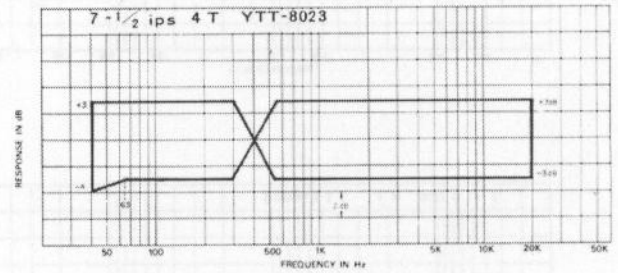
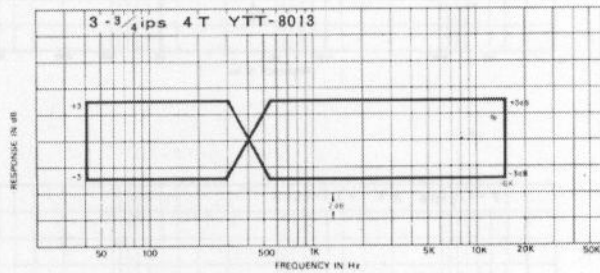
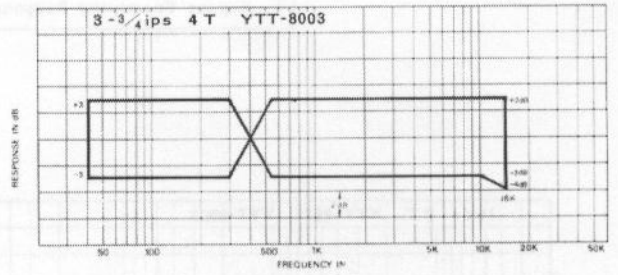
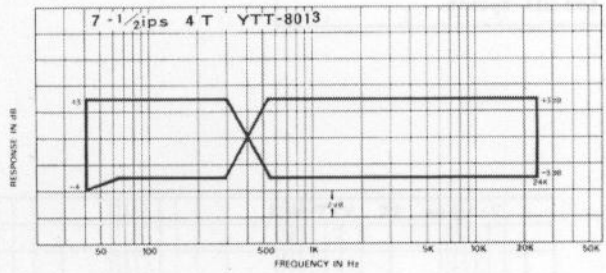

Fig. 16 Frequency Response Limits  
- Record -

## TROUBLESHOOTING

MALFUNCTION	POSSIBLE SOURCE OF TROUBLE
- Pilot Lamps (in VU Meters) do not illuminate when power is applied.....	Fuse F701 (2A) burned out
- Fuse burns out (blows) when power is applied.....	Defective Power transformer (T151)
- Capstan will not rotate.....	<ul style="list-style-type: none"> <li>Specified 24V DC present on the CAPSTAN MOTOR ASS'Y J152 Pins #1~7                             <ul style="list-style-type: none"> <li>└ Defective CAPSTAN ASS'Y</li> </ul> </li> <li>Specified 24V DC not present on the STABILIZER UNIT J21 Pins #11,#12                             <ul style="list-style-type: none"> <li>└ Defective STABILIZER UNIT ASS'Y or Connector loose</li> </ul> </li> <li>Specified 32V DC not present on the STABILIZER UNIT J21 Pins #13,#14                             <ul style="list-style-type: none"> <li>└ Defective D10~D13 or Power transformer (T151)</li> </ul> </li> </ul>
- Transport inoperative in Forward Playback.....	Faulty Safety switch (SW155)
- Pinch roller fails to engage completely.....	<ul style="list-style-type: none"> <li>Voltage present on the CAP SOL.1 terminals                             <ul style="list-style-type: none"> <li>└ CAP SOL.1 Disconnected</li> </ul> </li> <li>High-Level voltage (approx.3V) present on the SOLENOID DRIVE UNIT J121 Pin #3                             <ul style="list-style-type: none"> <li>└ Defective Q121 or Q122</li> </ul> </li> <li>High-Level output voltage not present on the CONTROL UNIT P41 Pin #1                             <ul style="list-style-type: none"> <li>└ Defective CONTROL UNIT</li> </ul> </li> </ul>
- Right Reel Motor does not rotate.....	<ul style="list-style-type: none"> <li>Fast Forward OK .....Defective Q71 or K72                             <ul style="list-style-type: none"> <li>└ High-Level output voltage not present on the CONTROL UNIT P41 Pins #1 or #2                                     <ul style="list-style-type: none"> <li>└ Defective CONTROL UNIT</li> </ul> </li> <li>└ High-Level output voltage present on the REEL MOTOR DRIVE UNIT at H terminal                                     <ul style="list-style-type: none"> <li>└ Defective Reel Motor</li> </ul> </li> </ul> </li> </ul>
- Neither Reel Motor rotates.....	<ul style="list-style-type: none"> <li>Brakes not dis-engaged                             <ul style="list-style-type: none"> <li>└ Disconnected brake Solenoid R or L, Defective Q125 or Q126</li> </ul> </li> <li>High-Level output voltage present on the SOLENOID DRIVE UNIT J21 Pin #8                             <ul style="list-style-type: none"> <li>└ Defective SOLENOID DRIVE UNIT</li> </ul> </li> <li>High-Level output voltage not present on the CONTROL UNIT P41 Pin #2                             <ul style="list-style-type: none"> <li>└ Defective CONTROL UNIT</li> </ul> </li> </ul>
- Fast Forward or Rewind modes inoperative (Playback is OK).....	<ul style="list-style-type: none"> <li>High-Level output voltage not present on the CONTROL UNIT P41 Pins #4,#7                             <ul style="list-style-type: none"> <li>└ Defective CONTROL UNIT</li> </ul> </li> <li>High-Level output voltage present on the CONTROL UNIT P41 Pin #2                             <ul style="list-style-type: none"> <li>└ Defective SOLENOID DRIVE UNIT (Q125,Q126)</li> </ul> </li> </ul>

# TROUBLESHOOTING

MALFUNCTION	POSSIBLE SOURCE OF TROUBLE
- Transport inoperative (Capstan only rotates).....	<ul style="list-style-type: none"> <li>Specified 8V DC present on the STABILIZER UNIT J21 Pins #5, #6                             <ul style="list-style-type: none"> <li>↳ Defective STABILIZER UNIT</li> </ul> </li> <li>Specified 8V DC not present on the STABILIZER UNIT J21 Pins #5, #6                             <ul style="list-style-type: none"> <li>↳ Faulty D14~D17 or fuse F2 (2A)</li> </ul> </li> </ul>
- Cannot select PAUSE.....	Defective CONTROL UNIT
- Amplifier inoperative.....	<ul style="list-style-type: none"> <li>Voltage not present on P151 at Pin #10 or #11 (To ampl. connector)                             <ul style="list-style-type: none"> <li>↳ Fuse F1 (2A), F4 (0.5A) burned out</li> </ul> </li> <li>Voltage present on P151 at Pins #10 or #11                             <ul style="list-style-type: none"> <li>↳ Defective Q601, Q602, Q603 (on AMPL. STABILIZER UNIT)</li> </ul> </li> </ul>
- Playback audio intermittent or absent	
a) Both channels inoperative..... (SOURCE OK)	Defective Q207, Q208, Q209 or associated parts
b) R-Ch or L-Ch inoperative.....	<ul style="list-style-type: none"> <li>SOURCE also inoperative                             <ul style="list-style-type: none"> <li>↳ Defective Q301 or associated parts</li> </ul> </li> <li>SOURCE Monitor function normal                             <ul style="list-style-type: none"> <li>↳ Defective Q201, Q203, Q205, Q207, Q251, Q253, Q255 or associated parts</li> </ul> </li> </ul>
- Playback sound is not clear.....	<ul style="list-style-type: none"> <li>High Freq. weak.....Dirty head, incorrect Adj. of VR201/203</li> <li>Sound distorted.....Defective Q201, 203, 205</li> </ul>
- VU Meter inoperative in TAPE Monitor mode..... (sound is normal)	Defective Q306 or associated parts, Faulty VU Meter ass'y
- Hum in playback signal.....	Defective Playback head
- Intermittent or absence of audio at PHONES jack.....	Defective Q303, Q305 Q307 or associated parts
- LINE IN signal is not applied to SOURCE..... (Playback normal)	Defective Q405, Q406, Q451, Q453...etc
- Will not Record.....	<ul style="list-style-type: none"> <li>No Erase.....Defective K551, Q551 ~ 554, T551</li> <li>Erase normal.....Sound normal at SOURCE                             <ul style="list-style-type: none"> <li>↳ Defective Q507, Q509, Dirty or defective record head</li> </ul> </li> </ul>
- Recorded sound not clear.....	Dirty record head, incorrect Bias Adj. or Defective Q505
- Inoperative MIC Recording (LINE IN signal normal).....	Defective Q401~Q404....etc
- Hum in Recording signal.....	Defective Record head or P702 connector loose or heads magnetized

Note: Explanation of abbreviations and circuit component designations.  
 F...Fuse D...Diode SW...Switch K...Relay T...Transformer  
 J...Pin jack (Female) Connector P...Pin plug (male) connector  
 High-Level output voltage -Logic true level approx. +3V.  
 Refer to the circuit diagram for further assistance in locating  
 possible defective circuit components.



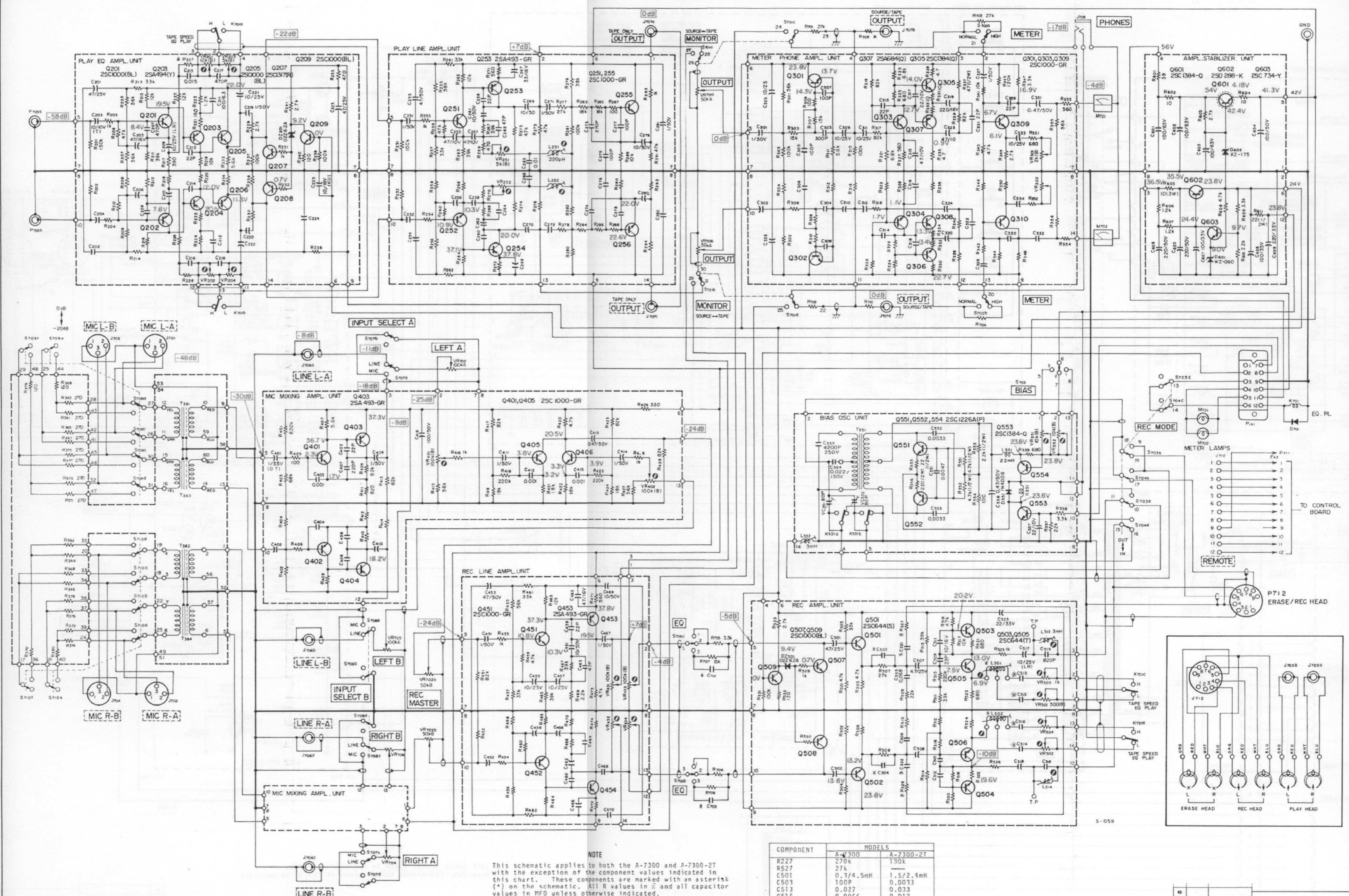

**NOTE**  
 This schematic applies to both the A-7300 and A-7300-2T with the exception of the component values indicated in this chart. These components are marked with an asterisk (\*) on the schematic. All R values in  $\Omega$  and all capacitor values in MFD unless otherwise indicated.  
 DC Voltages indicated were measured during PLAY mode. dB levels indicated were measured with input and output controls specified position.

COMPONENT	MODELS	
	A-7300	A-7300-2T
R227	270k	130k
R527	27k	
C501	0.3/4.5mH	1.5/2.4mH
C503	100P	0.0033
C513	0.027	0.033
C515	0.0056	0.012
C521	0.0015	
C701	470P	0.0033

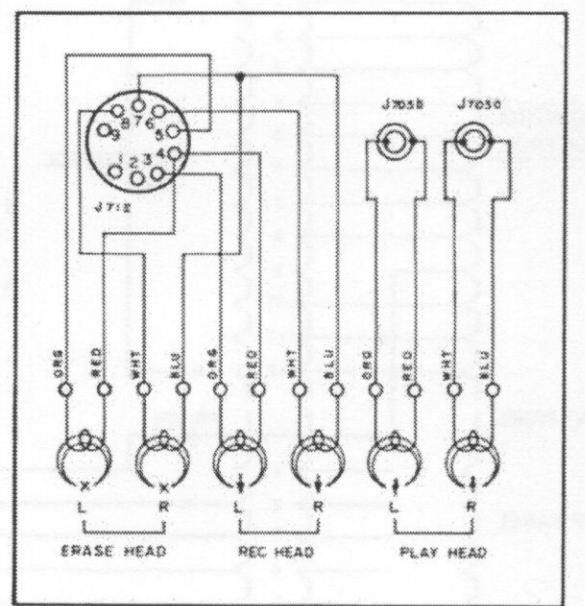

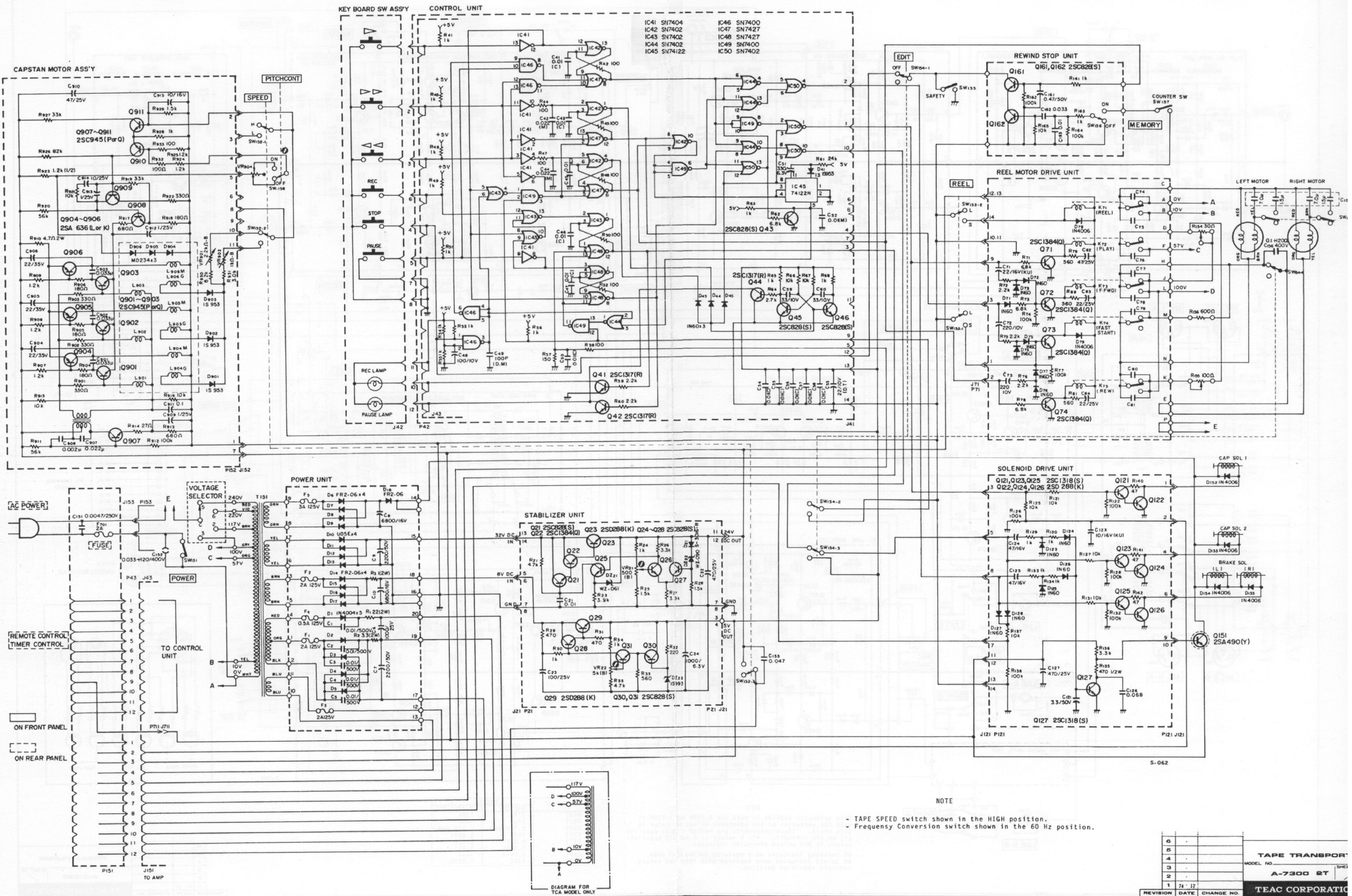

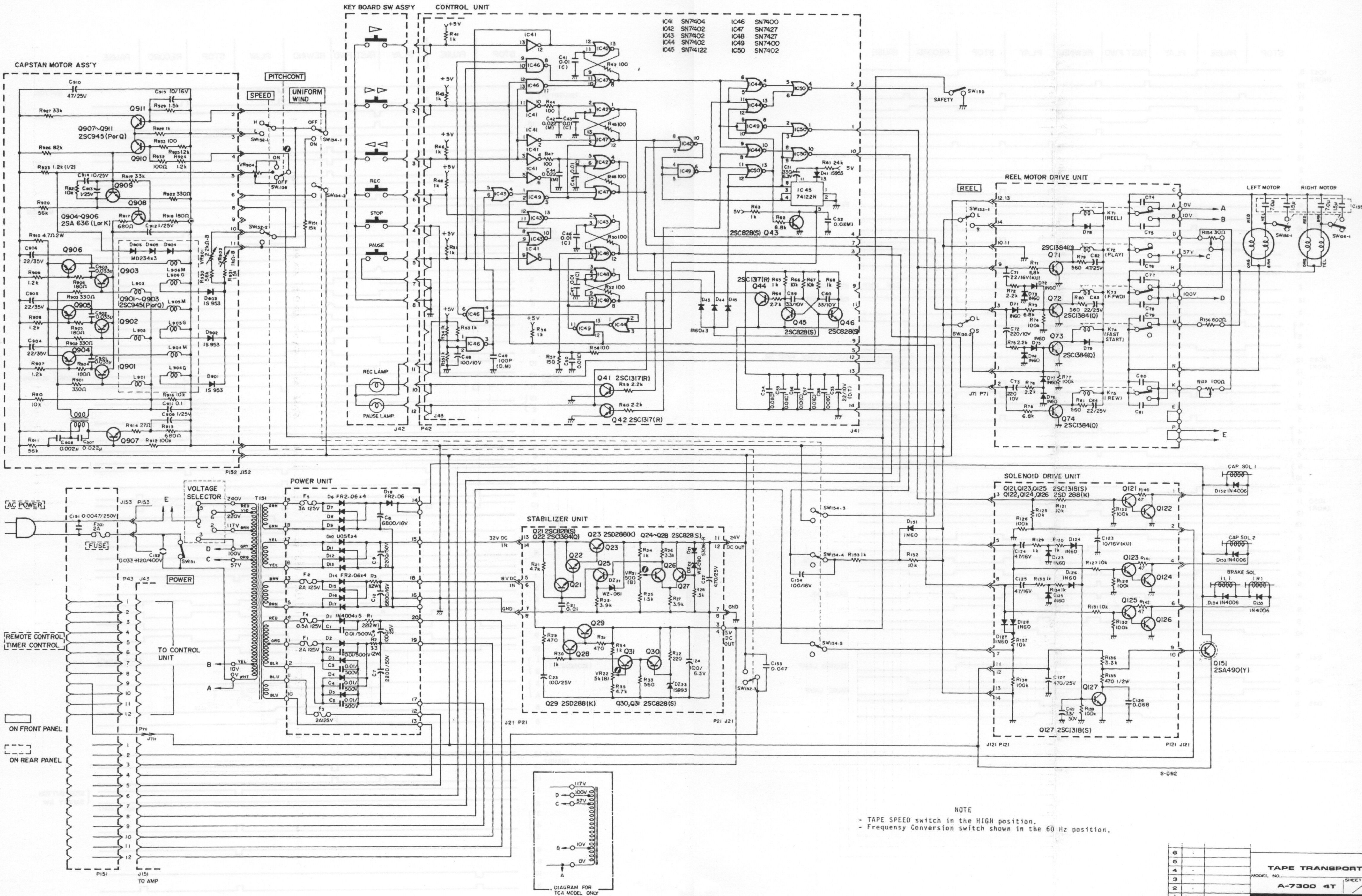

- IC41 SN7404
- IC42 SN7402
- IC43 SN7402
- IC44 SN7402
- IC45 SN74122
- IC46 SN7400
- IC47 SN7427
- IC48 SN7400
- IC49 SN7400
- IC50 SN7402

NOTE  
 - TAPE SPEED switch in the HIGH position.  
 - Frequency Conversion switch shown in the 60 Hz position.

6			
5			
4			
3			
2			
1	24	12	
REVISION	DATE	CHANGE NO.	



# SERVICE INFORMATION FROM TEAC

date: July, 1976  
Supplement 2  
#61

subj: A7300/A7300-2T INPUT SENSITIVITY MODIFICATION

The Microphone input sensitivity of this new model Tape Deck has been designed to match current manufactures of high quality Microphones, which have outputs of -57 dB up to -38 dB.

If other microphones with outputs in the -70 dB range are to be used, Mic record level gain of the deck may be found to be inadequate.

If customer insists on employing such lower output microphones, the deck's microphone input sensitivity would have to be modified. Note that this would be a custombuilding job, not covered by warranty.

The modification, not affecting other performance parameters of the deck, involves the change of value in one capacitor, the addition of another capacitor and a resistor in the first stage of the microphone preamp circuit. Modification data, shown for left channel, appears in the schematic below:

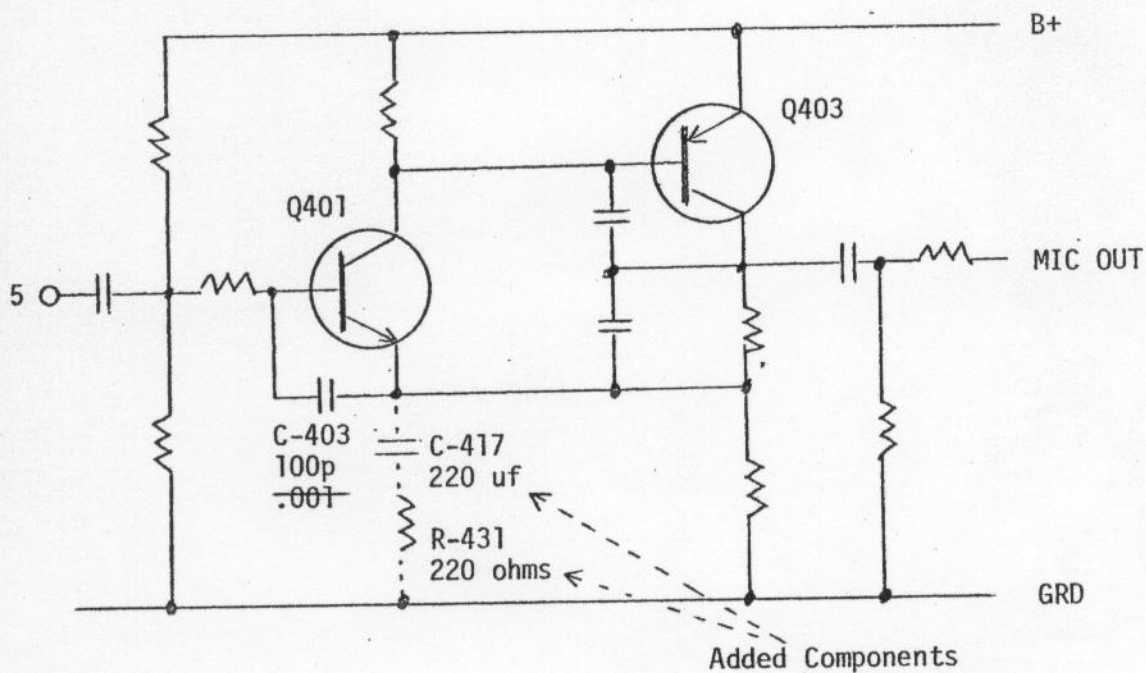

# SERVICE INFORMATION FROM TEAC

date: July, 1976  
Supplement 3  
Page 1 of 2  
#62

subj: A7300/A7300-2T BRAKE ADJUSTMENT

Inadvertently brake adjustment procedure was not included in the first printing of the Service Manual on this model.

For such procedure, please refer to Supplement 3-A on next page.

## BRAKE TORQUE

The brake torque is actuated mechanically. Pressure is set by the variable spring force. While making these measurements and adjustments, be careful not to bend the brake bands. As brake torque will change with cleaning, brake drums and brake shoes should be cleaned only when absolutely necessary. If cleaning is required, use TEAC cleaner TZ-261B. After cleaning operate the machine for a month of normal operation before performing the procedures below.

Brake adjustments are made with NO power connected to the equipment.

1. Place an empty 2" hub reel on the left reel table, and fasten one end of a 30" length of string to the reel anchor.
2. Wind several turns of string counterclockwise around the hub and attach a suitable spring scale to the free end of the string.
3. Take a reading only when the reel is in steady motion since the force required to overcome static friction will produce a false, excessively high initial reading.
4. The reading should be 1000 g-cm  $\pm$ 200 g-cm.
5. If adjustment is required, loosen the 2 screws shown and position the brake for optimum torque.
6. The adjustment of the right brake is the same, with the exception that rotations are clockwise. (Wind string **CLOCKWISE** around reel hub.)

NOTE: The difference in reading between the right and left brakes should be kept within 100 g-cm.

To measure torque when using a reel with a hub radius of other than 5.0cm refer to the following page.

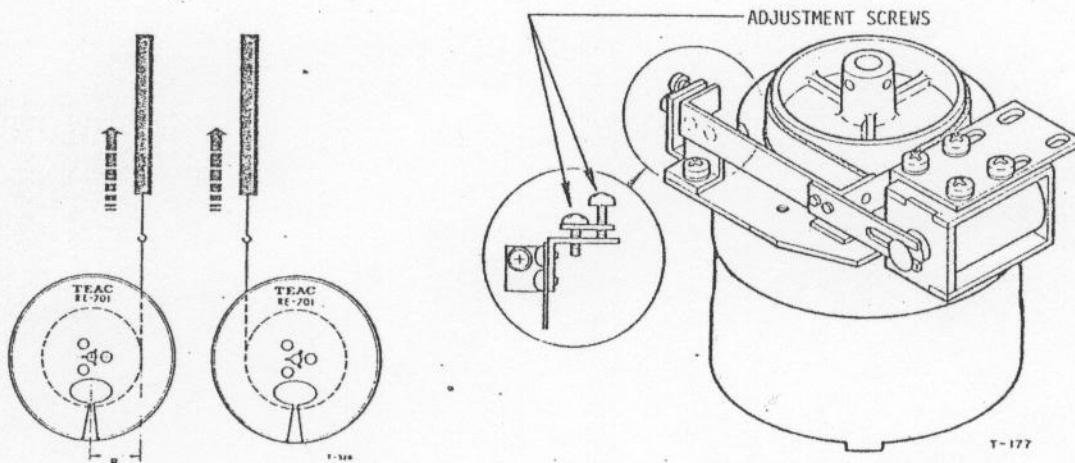

Torque Measurement and Brake Assy ADJ. Location

# SERVICE INFORMATION FROM TEAC

date: July, 1976  
Supplement #1  
#60

subj: A-7300/2T ELECTRICAL ADJUSTMENT CORRECTION

Refer to Page 10 of the Service Manual and make the following corrections:

REF. NOS.	ITEM	SIGNAL SOURCE	INSTRUCTIONS
4	Monitor Level Setting	400 Hz -18 dB (97 mV)	<ol style="list-style-type: none"><li>1. Set Line Input Level Control to maximum.</li><li>2. Adjust to obtain the specified output level of 0 dB at Output Jacks.</li><li>3. Input Selector - Line.</li></ol>
5	VU Meter Level Set	400 Hz -8 dB (308 mV)	<ol style="list-style-type: none"><li>1. Reduce Line Input Control to setting where level at Output Jacks is 0 dB.</li><li>2. Meter switch to Normal.</li><li>3. Adjust to obtain 0 VU on the VU Meter.</li></ol>



# SERVICE INFORMATION FROM TEAC

date: 1/15/80

#116

subj: NEW EDIT SWITCH FOR THE A-73002T

The Edit Switch on the A-73002T (only), part number 50444740 will be discontinued.

A substitute switch, part number 5134016000 will be made available in its place.

Since these two switches are physically and electrically different, refer to the diagram below for hookup.

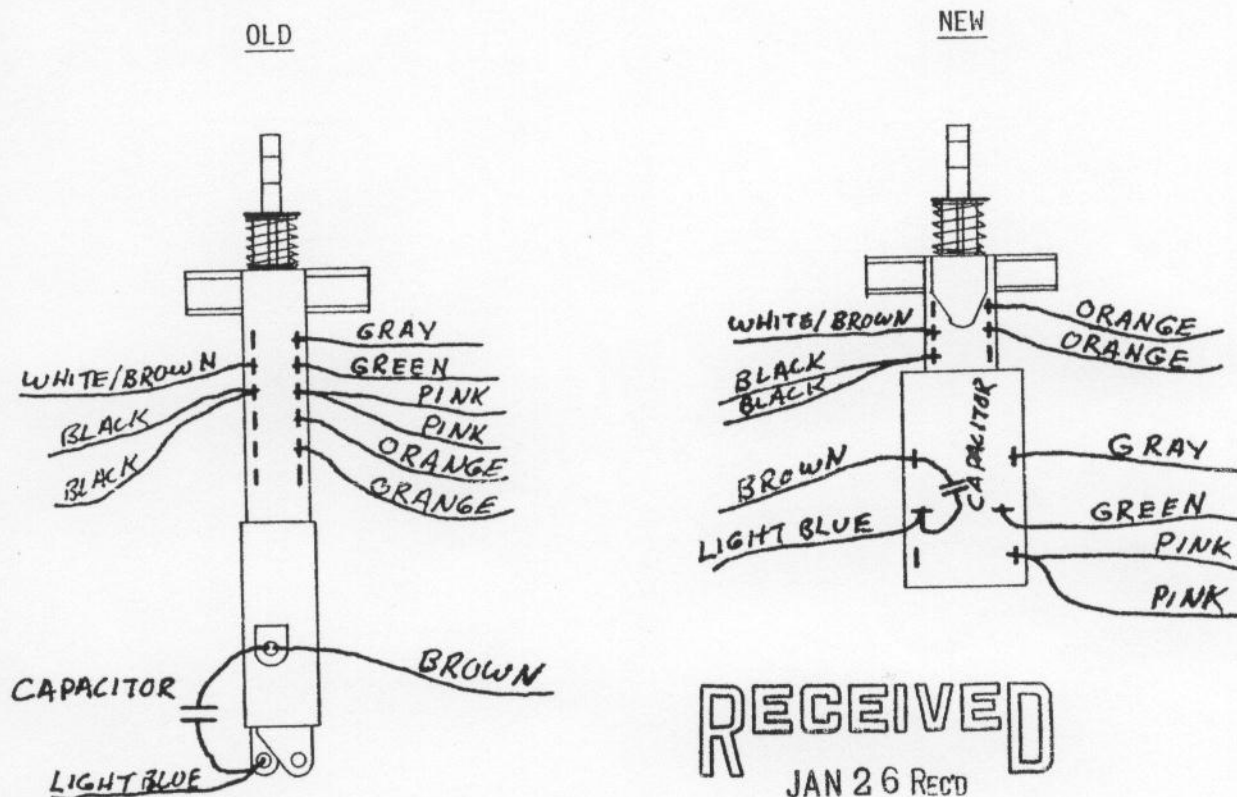

When wiring in the new switch, orient both the old and new switches as shown above, to facilitate re-wiring.

**TEAC** Corporation of America / 7733 Telegraph Road / Montebello, California 90640 / (213) 726-0303



**TEAC**

<b>TEAC CORPORATION</b>	3-7-3 NAKA-CHO, MUSASHINO, TOKYO	PHONE: (0422) 53-1111
<b>TEAC CORPORATION OF AMERICA</b>	2733 TELEGRAPH ROAD, MONTEBELLO, CALIFORNIA 90640	PHONE: (213) 726-0903
<b>TEAC TONBAND-ANLAGEN</b> VERTRIEBS GmbH	6200 WIESBADEN-ERBENHEIM, EGERSTRASSE 2, WEST GERMANY	PHONE: (06121) 74225 ~ 8
<b>TEAC HONGKONG LIMITED</b>	FLAT 78, PORTLAND HOUSE, 7TH FLOOR, BLOCK C, No. 41-D, MA TAU WEI ROAD, KOWLOON, HONG KONG.	PHONE: 3-659071

PRINTED IN JAPAN 0279211-2