

23

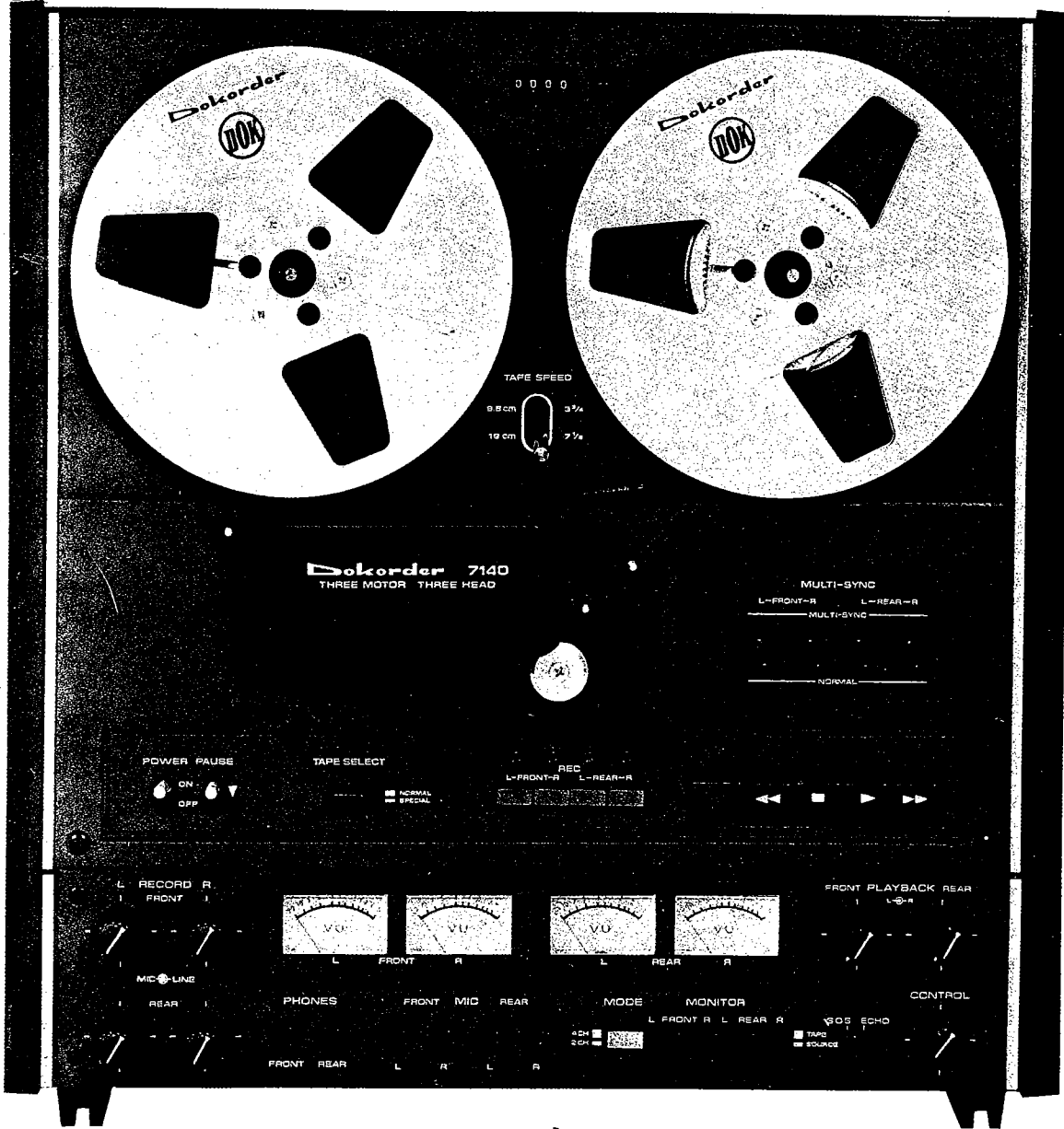

4-TRACK 4/2 CHANNEL STEREO/MONO TAPE DECK

Dokorder®
model 7140

DOKORDER 7140

SERVICE MANIA I

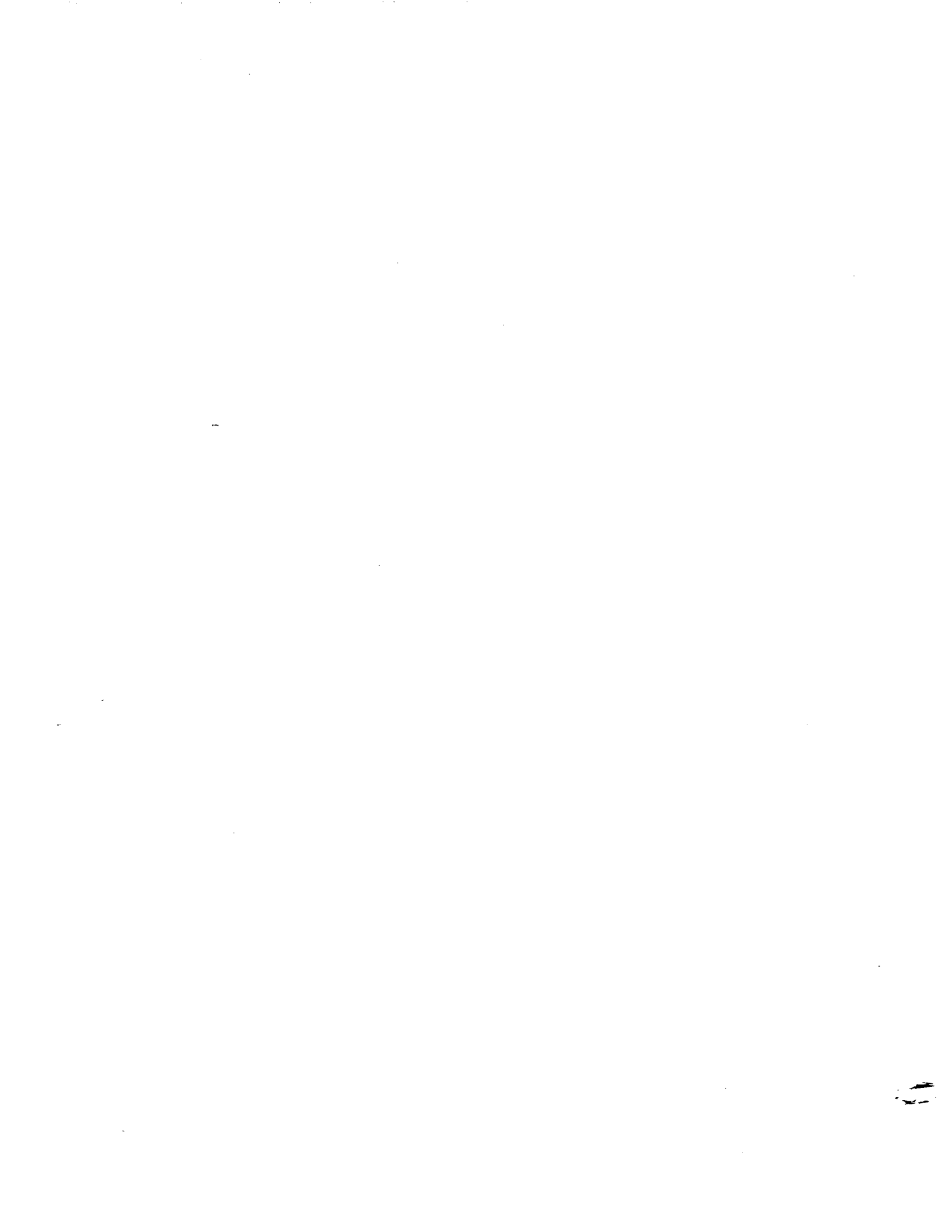

SERVICE MANUAL

TABLE OF CONTENTS

SERVICE MANUAL

SERVICE DATA
PARTS LOCATION
REMOVAL OF OUTER PARTS
REPLACEMENT OF WORN PARTS
HEAD ALIGNMENT – MECHANICAL –
MEASUREMENT, ADJUSTMENT AND CHECKING PROCEDURES
– MECHANICAL –
MEASUREMENT, ADJUSTMENT AND CHECKING PROCEDURES
– ELECTRICAL –
PACKAGING PROCEDURES
TROUBLE SHOOTING CHART
WARRANTY
EXPLODED VIEWS AND PARTS LISTS
SCHEMATIC DIAGRAM

SERVICE TIPS

CLEANING
DEMAGNETIZING
LUBRICATION
AVOID THESE PLACES TO PREVENT DAMAGE
COLOR-CODING CHART
HOW TO CHECK BROKEN TRANSISTORS AND DIODES

TECHNICAL TIPS

PRINCIPLES OF SPECIAL CIRCUITS
EXPLANATION ABOUT EASY-LOADING MECHANISM
DETAILED EXPLANATION OF REEL TABLE HEIGHT ADJUSTMENT
MECHANISM



SERVICE DATA

MECHANICAL

Recording/Playback System:	4-track 4-channel 4-track 2-channel recording and playback
Tape width:	Standard 1/4 inch tape
Reel capacity:	7" or smaller
Motor:	Three (one 4-pole synchronous for capstan drive) (two 6-pole eddy-current for reel drive)
Tape speeds:	7-1/2 ips (19 cm) and 3-3/4 ips (9.5 cm)
Monitoring:	Full tape/source
Level indication:	4 illuminated VU meters
Operation position:	Vertical
Fast winding time:	120 seconds for 7" reel (1800 feet/60 Hz)
Wow and flutter:	Playback (RMS) 0.15% for 7-1/2 ips (19 cm) 0.20% for 3-3/4 ips (9.5 cm)
Heads:	Three (1 erase, 1 record, 1 playback)
Power requirements:	U.S.A. type 117V (60 Hz) Universal type 110, 117, 125, 200, 220, or 240 V (50/60)
Power consumption:	120 W
Weight:	40.7 lbs. net
Dimensions:	17-3/4 inch (H) X 16-7/8 inch (W) X 6-3/4 inch (D)

ELECTRICAL

Transistors:	2SC-693 (G)..... 4	2SC-971 2
	2SD-313 (E) or (F)-3	2SC-693 (F) or (G)-12
	2SC-945 (P, Q) or (R)-2	2SC-536 (F) or (G)- 8
Diodes:	IS 2473 44	IS 188 10
	SIB 01-02..... 7	
Equalization:	NAB	
Bias frequency:	130 KHz \pm 10 KHz Push-pull oscillator	
Frequency response:	7-1/2 ips 50 Hz \sim 20KHz \pm 3 dB	
Signal to noise ratio:	Over all (RMS) 45 dB Playback (RMS) 48 dB 45 dB adjacent track at 1 KHz	
Channel separation:	40 dB channel to channel at 1 KHz	
Input, per channel:	Microphone sensitivity..... 0.775 mV impedance 15 K ohms Line sensitivity..... 77.5 mV impedance 150 K ohms	
Output, per channel:	Line sensitivity..... 0.775 mV impedance 20 K ohms Headphones output level 2.0 mW impedance 8 ohms	
Rec/PB connector:	DIN (German standard)	

Note: Specification are subject to change without notice for purpose of improvement.



PARTS LOCATION

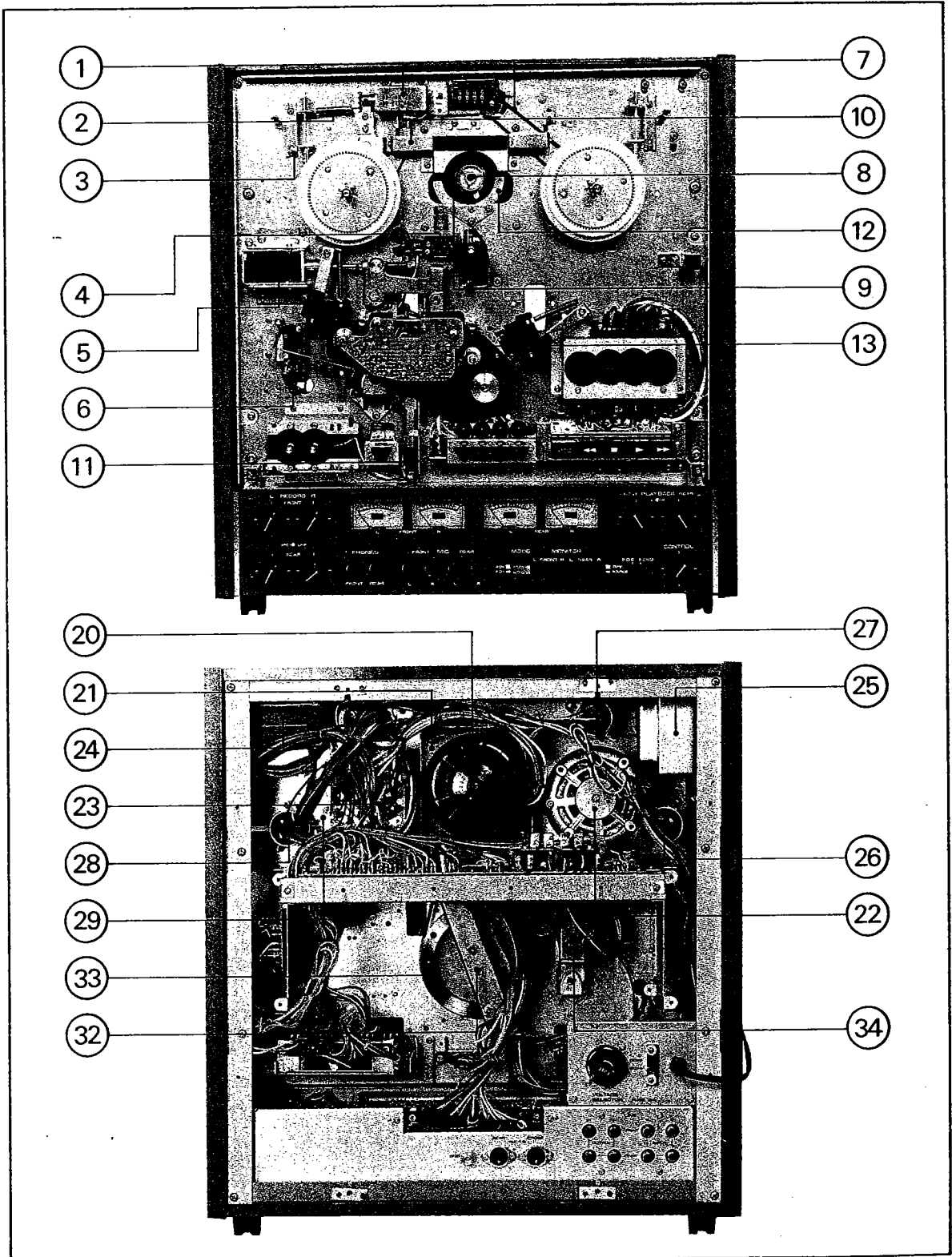



2

REMOVAL OF OUTER PARTS

CAUTIONS

1. Before attempting to remove the outer parts, be sure to unplug the power cable.
2. Do not try to separate each assembly into its elements.
3. Do not try to separate each part into its elements; the replacement and repair parts are integral by themselves as the parts illustrations show.
4. Whenever a screw or some part accidentally drops inside the tape deck, be sure to remove it; if it is not, damage may occur due to short circuits, etc., when the power is turned on.

1. REMOVAL OF FRONT PANEL FOR MECHANICAL ASSEMBLY

1. Pull the HEAD COVER (6) toward you.
2. When the HEAD COVER is removed, turn all the lever switches upward (TAPE SPEED SWITCH (4), four MULTI-SYNC SWITCHES (35) (36) (37) (38), PAUSE SWITCH (9) and POWER SWITCH (8)).
3. Remove the two banana plugs that hold the HEAD COVER by turning them counterclockwise with pliers or a box driver.
4. When the banana plugs are removed, loosen the screws ($\oplus M 4 \times 8 \times 4$ and $\oplus M 3 \times 20 \times 2$) that fasten the FRONT PANEL FOR AMPLIFIER ASSEMBLY, and remove the screws ($\oplus M 4 \times 8 \times 4$) that fasten the FRONT PANEL FOR MECHANICAL ASSEMBLY by turning them counterclockwise with a cross-headed screwdriver.
5. When the screws are removed, remove the FRONT PANEL FOR MECHANICAL ASSEMBLY.

2. REMOVAL OF FRONT PANEL FOR AMPLIFIER ASSEMBLY

1. Remove the knobs on the controls (four MIC RECORD LEVEL CONTROLS (17) (18) (21) (22), four LINE RECORD LEVEL CONTROLS (19) (20) (23) (24), four PLAYBACK LEVEL CONTROLS (50) (51) (52) (53) and SOUND-ON-SOUND/ECHO RECORD LEVEL CONTROL (60)).
2. When the knobs are removed, remove the front panel-fastening screws ($\oplus M 4 \times 8 \times 4$ and $\oplus M 3 \times 20 \times 2$) by turning them counterclockwise with a cross-headed screwdriver.

3. REMOVAL OF TOP AND BOTTOM BOARDS

1. Remove the top board-fastening screws ($\oplus M 3 \times 6 \times 6$) with a cross-headed screwdriver.
2. Remove the bottom board-fastening screws ($\oplus M 3 \times 18 \times 4$) with a cross-headed screwdriver.
3. When two legs are detached, remove the bottom board-fastening screws ($\oplus M 3 \times 6 \times 2$) at the center of the board with a cross-headed screwdriver.

NOTE

The top board-fastening screws are plated black, while the bottom board-fastening screws are not.

4. REMOVAL OF REAR PANEL

1. Set the protruding bar of the flywheel-locking screw in line with the slot in the rear panel.
2. Remove the rear panel-fastening screws ($\oplus M 3 \times 10 \times 8$) with a cross-headed screwdriver.
3. Before removing the rear panel, pull out the power cable through the hole in the rear panel.



NOTE

There are washers below the screws (\oplus M 3 \times 10 \times 8) to protect the panel; be careful not to lose them.

5. REMOVAL OF SIDE BOARDS

Twelve tapping screws (\oplus 4 \times 12) fasten both side boards; two are located on the upper and lower side of each of the boards, and four more on each of the front and rear panels. To remove them, turn the tapping screws counterclockwise.

NOTE

The tapping screws are fastened more strongly than other screws. So, in trying to remove the side boards while the front and rear panels and the top and bottom boards are in place, be careful not to damage the heads of the screws by undue force.



REPLACEMENT OF WORN PARTS

TABLE OF CONTENTS

- 1. REPLACEMENT OF HEADS**
 - 1-1. REPLACEMENT OF HEAD ASSEMBLY
 - 1-2. REPLACEMENT OF HEADS
REPLACEMENT OF ERASE HEAD
REPLACEMENT OF RECORD HEAD
REPLACEMENT OF PLAY HEAD
 - 2. REPLACEMENT OF CAPSTAN SLEEVE AND PINCH ROLLER**
 - 2-1. REPLACEMENT OF CAPSTAN SLEEVE
 - 2-2. REPLACEMENT OF PINCH ROLLER
 - 3. REPLACEMENT OF MOTORS**
 - 3-1. REPLACEMENT OF CAPSTAN MOTOR
 - 3-2. REPLACEMENT OF REEL MOTORS
 - 4. REPLACEMENT OF BELTS**
 - 4-1. REPLACEMENT OF COUNTER BELT
 - 4-2. REPLACEMENT OF CAPSTAN BELT
 - 5. REPLACEMENT OF BRAKE BANDS**
-



1. REPLACEMENT OF HEADS

CAUTION

Before attempting to replace the head assembly or one of the heads of the tape deck with a new one, be sure to set the POWER SWITCH (8) to the off position or unplug the power cable from the AC outlet. And before installing the replacement part, make notes of the color coding and connections of the leads that run from the heads to the connectors.

When the replacement procedure is finished, it is imperative to demagnetize the heads.

1-1. REPLACEMENT OF HEAD ASSEMBLY

1. Remove the HEAD COVER (6) on the front panel, then the head assembly can be seen.
2. Remove the two head assembly-fastening screws (+ M 4 X 8) by turning them counterclockwise, and pull out the head assembly in the direction of the arrow in Figure 1-1.

NOTE: When removing the head assembly, hold the hexagonal bar on the head base with a spanner or pliers. Also be careful to select the screwdriver that securely fits the cross heads of the screws, otherwise the heads may be permanently damaged.

3. Mount the new head assembly on the head base and retighten the screws holding the hexagonal bar with a spanner or pliers.
4. When the replacement procedure is finished, paint-lock the heads of the head assembly-fastening screws.
5. Load a tape on the tape deck and set the tape deck to the play mode; examine the position of the heads and tape guides in relation to the running tape, reel flanges, etc.

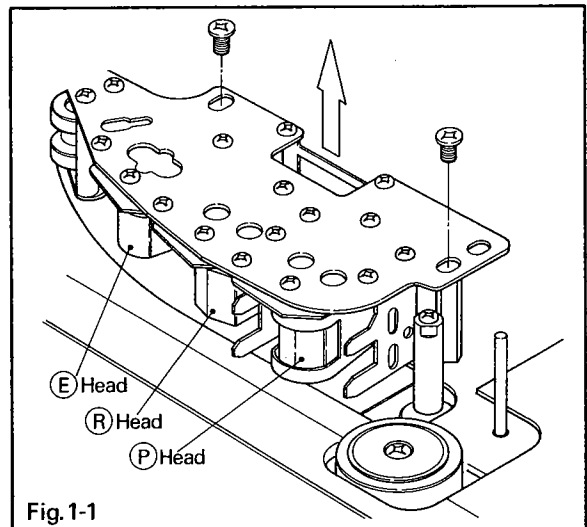

When the above-mentioned procedures are completed

1. Adjust the height of the heads and their horizontal and vertical angles to the tape. For adjustment, refer to "HEAD ALIGNMENT PROCEDURE."
2. Adjust the levels by turning the pre-set potentiometers. For adjustment refer to "ELECTRICAL ADJUSTMENT CHART."

1-2. REPLACEMENT OF HEADS

For equipment necessary for replacement of heads, refer to the section "EQUIPMENT NECESSARY FOR ADJUSTMENT AND REPLACEMENT."

For replacement of a head a 2mm box driver, a 2mm cross-headed driver and a 2mm minus-headed driver are necessary.

First pull off the head assembly from the head base before attempting to replace the head. The heads are located as the Figure 1-1 shows.



—REPLACEMENT OF ERASE HEAD—

1. The erase head is located to the left in the head assembly.
2. To remove the erase head, insert the 2mm box driver through a hole on the left side of the head base and remove the 2mm nut by turning it counterclockwise.
3. The removal procedure is as described in the Figure 1-2 (A).
4. When the erase head is removed, disconnect the leads on the opposite side of the head mount by a soldering iron. **NOTE:** Don't apply the soldering iron to the leads too long, as the leads insulation may be damaged.
5. Connect the leads to the new erase head by the soldering iron. Mount the erase head referring to the Figure 1-2 (A). Be careful not to mistake the top of the head spacer ring for its bottom. (Don't forget to check the soldered parts and connections.)
6. Insert the erase head into the head holder hole (E). Fit the washer and the 2mm nut, and then tighten it by turning the 2mm box driver clockwise.

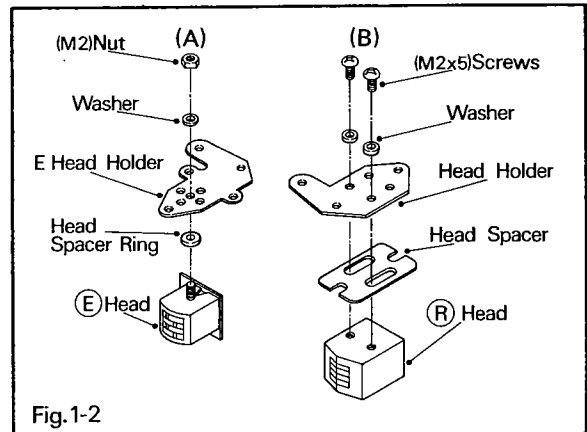

—NOTE—

Since the screw protruding from the erase head is thin, be careful not to strip the thread when tightening the nut with the box driver.

7. When the replacement is finished follow step 5 of the preceding section 1-1. "REPLACEMENT OF HEAD ASSEMBLY" for adjustment.
8. When the above-mentioned procedures are completed, paint-lock the heads of the 2mm nut.

—REPLACEMENT OF RECORD HEAD—

1. The record head is located at the center of the head assembly.
2. To remove the record head, insert the 2mm cross-headed driver through a round hole at the center of the head base, and remove the head-fixing screws (\oplus M 2 X 5) by turning them counterclockwise.
3. When the head-fixing screws have been removed, the head spacer board will come off; be sure not to lose it.
4. The removal sequence is as shown in the Figure 1-2 (B).
5. When the record head is removed, follow step 4 in the preceding paragraph "REPLACEMENT OF ERASE HEAD."
6. Mount the new record head and connect the leads by the soldering iron. (Don't forget to check the soldered part and connections.)
7. Then mount the record head on the head assembly referring to the Figure 1-2 (B); insert the screws through the head holder hole and turn them clockwise by the 2mm cross-headed driver.
8. Mount the head assembly on the head base. When the replacement is finished, follow step 5 of the preceding section 1-1. "REPLACEMENT OF HEAD ASSEMBLY" for adjustment.



—REPLACEMENT OF PLAY HEAD—

1. The play head is located to the right in the head assembly.
2. To remove the play head, insert the 2mm minus-headed driver through a round hole on the right side of the head base, and remove the head-fixing screws (\ominus M 1.7 \times 4) by turning them counterclockwise.
3. The removal sequence is as shown in the Figure 1-3. When the head-fixing screws have been removed, the head holder and the head swing free. Then remove the head by turning the screws (\oplus M 2 \times 4), which hold the head shield and the head, counterclockwise by the 2mm cross-headed driver.
4. Follow steps 5 and 6 in the preceding paragraph "REPLACEMENT OF RECORD HEAD" for disconnecting and connecting the leads.
5. Re-mount the head on the head assembly referring to the Figure 1-3. Follow the specified sequence in the order given.
6. When the replacement is finished, follow step 5 of the preceding section 1-1. "REPLACEMENT OF HEAD ASSEMBLY" for adjustment.

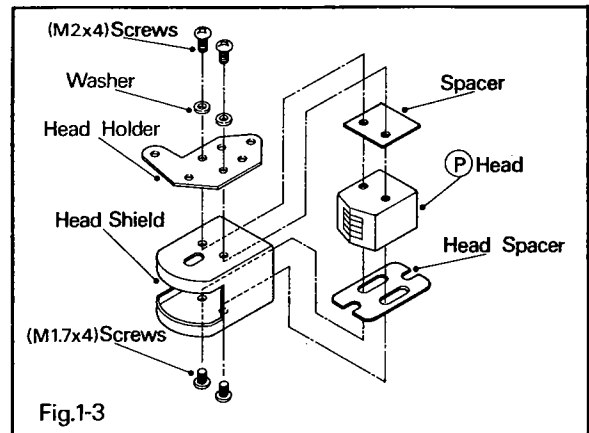



2. REPLACEMENT OF CAPSTAN SLEEVE AND PINCH ROLLER

CAUTION

Before attempting to replace the capstan sleeve or pinch roller of the tape deck with a new one, be sure to set the POWER SWITCH (8) to the off position or unplug the power cable from the AC outlet.

2-1. REPLACEMENT OF CAPSTAN SLEEVE

1. Remove the HEAD COVER (6) on the front panel by pulling it toward you.
2. Remove the capstan sleeve-fixing screws (⊕ M 3 × 12) by turning them counter-clockwise with a cross-headed driver.
NOTE: If the capstan sleeve turns with the screw when loosened with the driver, the fixing screws are tightened too strongly; pinch the upper flat part of the capstan sleeve with radio pliers as Figure 2-1 shows. Then the screws can be removed easily.

3. Take out the screws (⊕ M 4 × 15) that are necessary for removal of the capstan sleeve. With a tape recorder of the Universal Type, the screws are supplied as accessories for cycle change; remove them from the vinyl bag.

4. Insert the screws (⊕ M 4 × 15) into the hole on the upper end of the capstan sleeve. When the cross-headed driver is turned clockwise while the upper flat part of the capstan sleeve is pinched by radio pliers, the capstan sleeve moves up.
5. When the capstan sleeve is freed from the capstan shaft, set the POWER SWITCH (8) to the ON position or plug the power cable into the AC outlet. When the capstan shaft begins to rotate, set the TAPE SPEED SWITCH (4) to the 9.5cm (3¾ips) position.
6. Insert the new capstan sleeve into the rotating capstan shaft and push it gently with your finger until the capstan sleeve begins to rotate together with the capstan shaft. Then the contact of the capstan sleeve with the capstan shaft is appropriate.
7. Then set the POWER SWITCH (8) to the off position, remount the screws (⊕ M 3 × 12) that were removed previously, and tighten them by turning them clockwise, while holding the upper flat part of the capstan sleeve with radio pliers.
8. Load the test tape*, depress the PLAY BUTTON and let the test tape run.

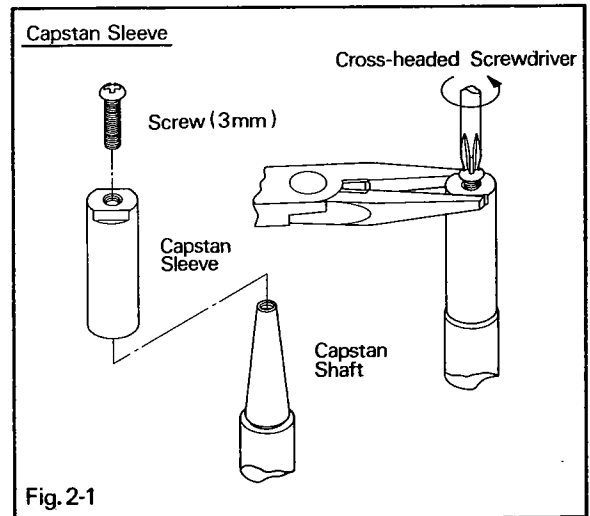

When the above-mentioned procedures are completed

Perform wow/flutter and speed variation measurements with the loaded test tape* for the respective measurements. For the detailed procedure, refer to the section "WOW/FLUTTER AND SPEED VARIATION MEASUREMENT."



—2-2. REPLACEMENT OF PINCH ROLLER

1. Remove the pinch roller-fixing screws (⊕ M 4 X 8) by turning them counter-clockwise with a cross-headed driver.
2. Remove the dressing plate and nylon washer, extract the pinch roller and fit a new pinch roller from the pinch roller shaft.

NOTE: The pinch roller, when extracted, may be tainted with oil from the nylon washer below the pinch roller. Therefore, when the pinch roller is extracted, remove the nylon washer from it and fit it onto the pinch roller shaft before fitting the new pinch roller. (See Figure 2-2.)

3. After the new pinch roller is fitted, apply a drop of oil to the pinch roller shaft. Then mount the upper nylon washer and dressing plate, then remount the pinch roller-fixing screws and turn them clockwise until they are securely tightened.
4. When the replacement procedure is completed, follow step 8 in the preceding paragraph "REPLACEMENT OF CAPSTAN SLEEVE".

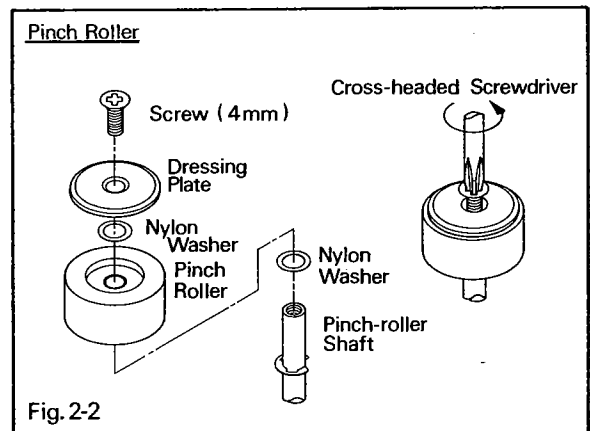



3. REPLACEMENT OF MOTORS

When about to replace a motor, first remove the FRONT and REAR PANELS, referring to the section "REMOVAL OF OUTER PARTS." Also be sure to unplug the power cable from the AC outlet.

For equipment necessary for replacement of the capstan motor and the reel motors, refer to the section "EQUIPMENT NECESSARY FOR ADJUSTMENT AND REPLACEMENT."

—3-1. REPLACEMENT OF CAPSTAN MOTOR—

1. Remove motor pulley (8) hooked belt (9) through a hole located at the center of the front deck chassis.
2. Reverse the tape deck so that the front faces to the rear. Remove the four motor chassis (21) fastening screws (⊕ M 4 × 8), then the motor assembly will be detached in the manner as shown in Figure 3-1.
3. Remove the capstan motor (20) fastening screws (⊕ M 4 × 8) of the motor assembly by turning them counterclockwise, and remove the capstan motor from the motor chassis.
4. Remove the motor pulley from the capstan motor shaft by turning the Allen driver counterclockwise.
5. Mount the motor pulley on the new capstan motor shaft. And trying to maintain the distance, noted in step 4 above, tighten the motor pulley-fastening screws by the Allen driver.
6. When the motor pulley is mounted, mount the new capstan motor on the motor chassis by the capstan motor-fastening screws, and screw-lock the heads of these screws.
7. When the above procedures are finished, the motor chassis looks as shown in Figure 3-1. Remount the motor assembly at its original location, and screw-lock the heads of the screws. Then turn the deck forward to face the front, and hook the belt onto the motor pulley.
8. The figure 3-2 shows the sequence in which the capstan motor should be separated into its elements.

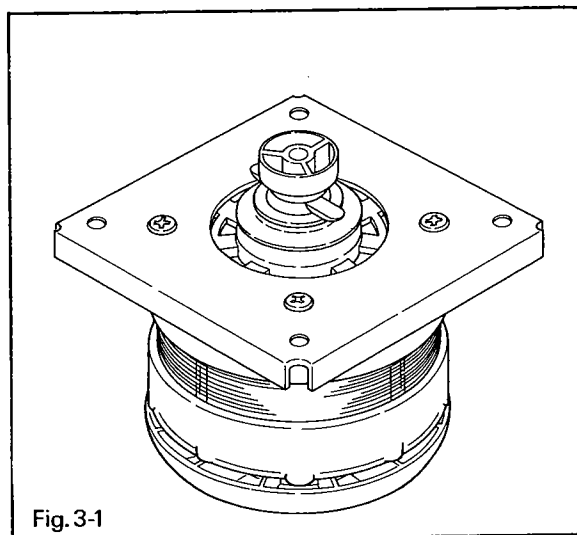

Fig. 3-1

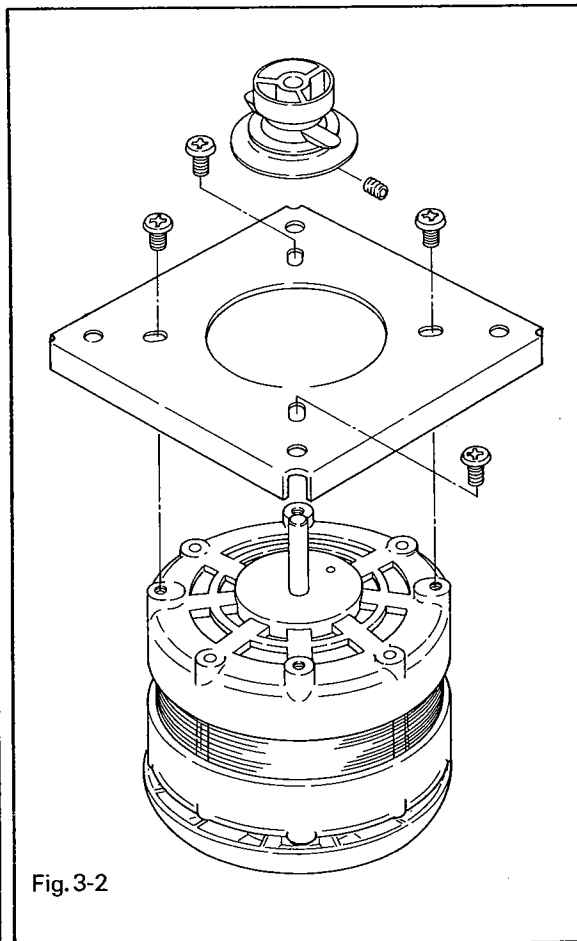

Fig. 3-2



When the above-mentioned procedures are completed

Perform the wow/flutter and speed variation measurements. For the detailed procedures, refer to the appropriate section.

3-2. REPLACEMENT OF REEL MOTORS

Two reel motors can be seen on the left and right of the tape deck when the panels are removed. The following steps show how to replace the right reel motor (viewed from front).

1. Remove the top board referring to the section "REMOVAL OF OUTER PARTS."
2. Turn the deck backwards to face the rear, and remove PC board (23), mounted on the reel motor.
3. When the PC board is removed, remove the four screws (\oplus M 4 X 8) that secure PC board holder (29), and remove the PC board holder from the reel motor.
4. Turn the deck forward to face the front and remove the reel table, mounted on the right reel motor. For removal of the reel table, refer to the section "REMOVAL OF COUNTER BELT."
5. When the reel table is removed, the heads of four screws (\oplus M 4 X 8) securing the reel motor can be seen.
6. Remove the reel motor-fixing screws and pull out the reel motor by hand. To remount the reel motor, perform the reverse procedure given above.

When the replacement procedure is finished

1. Adjust the reel table height. Refer to the section "ADJUSTMENT OF TAPE TRAVEL PATH."
2. When the reel table height is adjusted, perform the wow/flutter and speed variation measurements. For detailed procedures, refer to the appropriate section.



4. REPLACEMENT OF BELTS

When about to replace belts, first remove the FRONT and REAR PANELS, referring to the section "REMOVAL OF OUTER PARTS." For equipment necessary for replacement of the counter belt and capstan belt, refer to the section "EQUIPMENT NECESSARY FOR ADJUSTMENT AND REPLACEMENT."

—4.1. REPLACEMENT OF COUNTER BELT—

1. Remove one end of the belt that is hooked to the counter pulley (indicated ① in the Figure 4-1).
2. When the belt is unhooked, it unstretches to its original size. Then pass that end of the belt below the brake connector board and the brake connector board guide.
3. Pull out the belt by passing it between the brake band ④ and the brake drum ⑤.
4. Pass the new counter belt between the brake band and the brake band guide, and hook it into the belt slot on the reel table.

NOTE: To prevent damage to the belt, take care not to scrape the belt against any possible rough edges of the brake band and/or brake band guide.

5. Holding the end of the belt hooked on the belt slot on the reel table, pass the other end under the brake connector board ② and the brake connector board guide ③.
6. Hook that end onto the counter pulley ①.
7. When both ends of the belt are hooked, turn the reel table slowly counterclockwise and check that the digits in the counter move from lower to higher numbers.

- During the above procedure, when the distance between the brake band and brake band guide is too small to allow the belt to pass through, remove the reel table first. To do so, follow the steps indicated as follows.

1. Remove the top board referring to the section "REMOVAL OF OUTER PARTS".
2. Insert the Allen driver through the hole on the deck chassis, turn the reel table-fastening screws counterclockwise and detach the reel table from the motor shaft. (See Figure 4-2.)
3. Hook one end of the new belt on the counter pulley first, then pass the other end below the brake connector board and brake connector board guide, and hook it into the belt slot on the reel

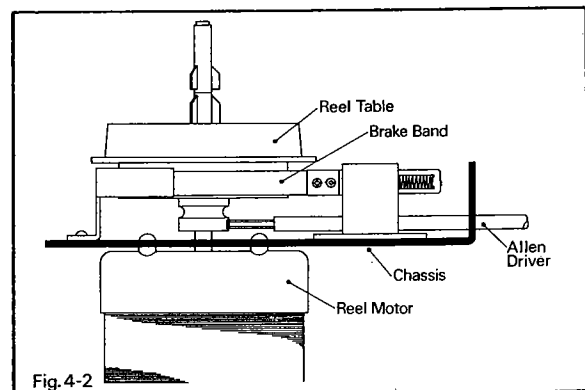
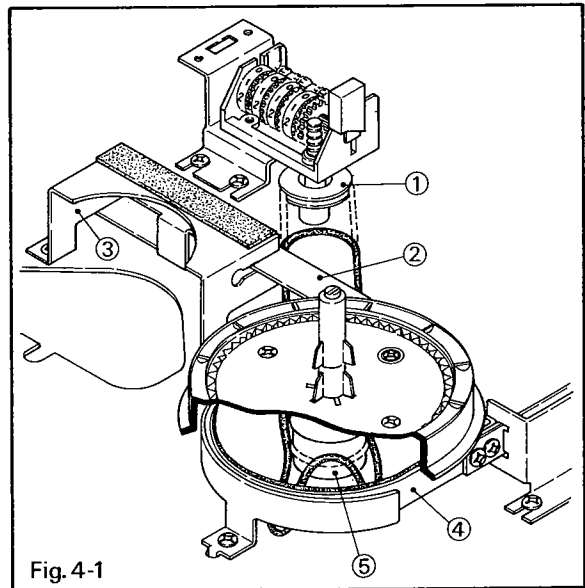



- table. Taking care not to let the hooked end of the belt loose, insert the reel table on the motor shaft and fasten the screws that secure the reel table.
- When both ends of the belts are hooked in position, turn the reel table slowly counterclockwise and check that the digits in the counter move from high to lower number.

—When the replacement procedure is finished—

- Adjust the reel table height. Refer to the section "ADJUSTMENT OF TAPE TRAVEL PATH".
- When the reel table height is adjusted, perform the wow/flutter and speed variation measurements. For the detailed procedures, refer to the appropriate section.

—4.2. REPLACEMENT OF CAPSTAN BELT—

- Remove the four screws (\oplus 3 X 10) that secure the punched shield board (30)*, located on the control PC board, by turning them counterclockwise with the cross-headed screwdriver, and then remove the shield board (30).
- Remove the two screws (\oplus M 3 X 6) that secure the control PC board and turn the board upward as shown in Figure 4-3. Fix the control PC board there with adhesive tape not to let it drop down.
- Unhook one end of the belt, hooked to the motor pulley, through the hole at the center of the front deck chassis and pass it below the fork-shaped fitting.
- Now turn the tape deck to face the rear.
- Disconnect the 4-p connector, plugged to the equalizer change-over PC board (31), and lift the belt.
- Remove two screws (\oplus M 4 X 8) that secure the flywheel-fastening holder (32), and pull out the belt.
- Pass the new belt through the hole at the center of the deck chassis and hook one of its ends round the motor pulley, and pass it between the fork-shaped fitting.
- Pass the belt over the equalizer PC board, then connect the 4-p connector to the equalizer change-over PC board. Stretch the other end of the belt slowly toward the flywheel and hook it round the flywheel.
- When the belt is hooked round the flywheel, mount the flywheel holder and fasten it by turning the screws clockwise. Then paint-lock the heads of the two screws.
- When the belt is mounted, turn the capstan fan and check that both the capstan sleeve and the flywheel turn accordingly. Also check that the belt is not in contact with the fork-shaped fitting.

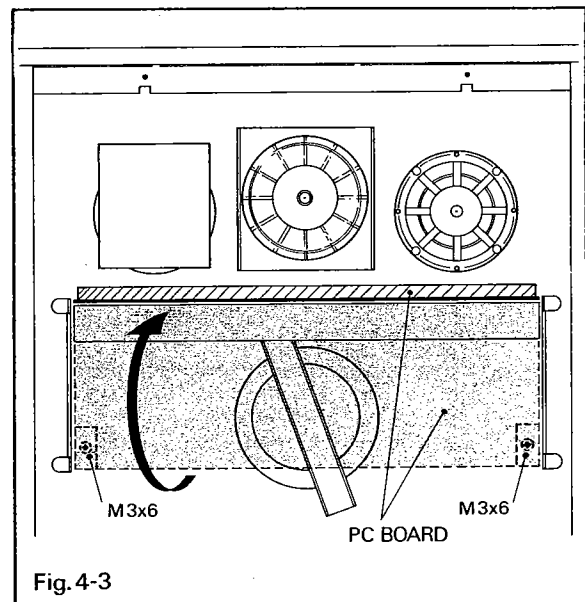

Fig. 4-3

—When the replacement procedure is finished—

- Change the tape speeds and check that the speed of the belt changes accordingly. There are cases where the speed does not change properly due, for example, to excessive vibrations of the belt itself.
- Perform the wow/flutter and speed variation measurements. For the detailed procedures, refer to the appropriate section.



5. REPLACEMENT OF BRAKE BANDS

1. First remove the top board referring to the section "REMOVAL OF OUTER PARTS."
2. For equipment necessary for replacement of the brake bands, refer to the section "EQUIPMENT NECESSARY FOR ADJUSTMENT AND REPLACEMENT."
3. Insert the Allen driver through the hole on the deck chassis and turn the screw on the reel table counterclockwise, then separate the reel table from the motor shaft.
4. Remove screw ① on the brake connector board by turning it counterclockwise (see Figure 5-1), and remove screw ② that secures the brake band holder. Then the brake band comes free of the brake band assembly.
5. When screw ③, that secures the brake band of the removed brake band assembly, is unscrewed, the brake band comes off. Then replace it by the new brake band, mount the new brake band between the brake control board and the brake band stopper, and tighten screw ③ to mount the brake band assembly.
6. To mount the brake band assembly on the deck chassis, first tighten screw ② and then ①.
NOTE: 1. To mount the brake band holder on the deck chassis, first push up the brake band holder in the direction of the arrow in the Figure 5-2 and then tighten screw ②.
2. When about to tighten the screw ①, do not forget to mount the 3mm washer first.
7. Following step 3 above, mount the reel table by turning the reel table-securing screw clockwise.

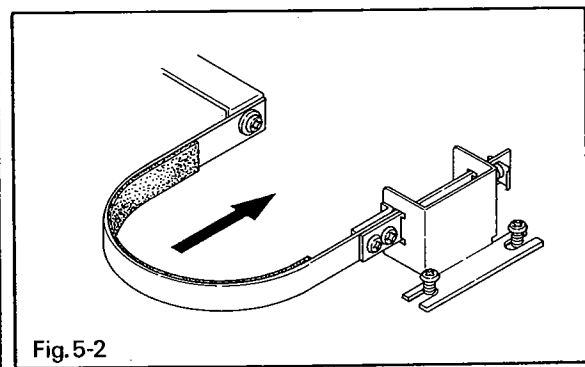
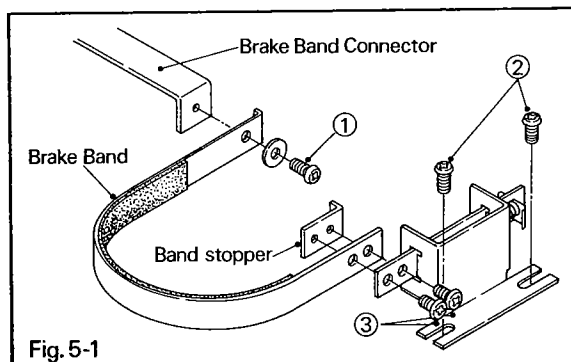

—When the replacement procedure is finished—

1. Adjust the reel table height. Refer to the section "ADJUSTMENT OF TAPE TRAVEL PATH."
2. Adjust the braking mechanism. Refer to the section "ADJUSTMENT OF BRAKE MECHANISM."



HEAD ALIGNMENT — MECHANICAL —

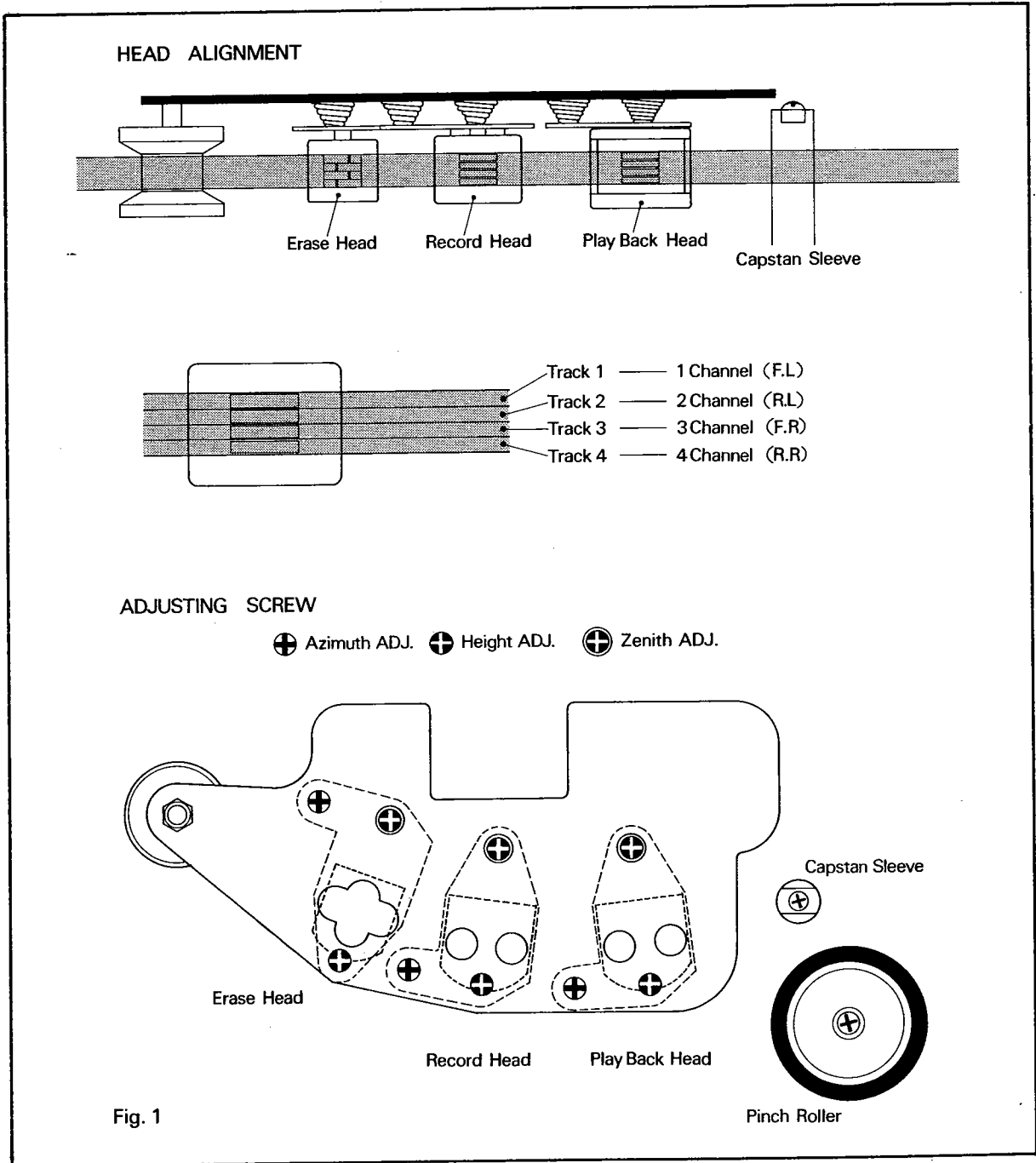



MEASUREMENT, ADJUSTMENT AND CHECKING PROCEDURES — MECHANICAL —

TABLE OF CONTENTS

- 1. ADJUSTMENT OF AUTO SHUT-OFF SWITCH**
 - 2. ADJUSTMENT OF PINCH ROLLER MECHANISM**
 - 2-1. ADJUSTMENT OF PINCH PRESSURE SOLENOID STROKE
 - 2-2. ADJUSTMENT OF PINCH ROLLER PRESSURE
 - 2-3. ADJUSTMENT OF PRESSURE SWITCH
 - 2-4. ADJUSTMENT OF PINCH ROLLER PUSH-UP SOLENOID
 - 2-5. ADJUSTMENT OF PUSH-UP SWITCH
 - 3. ADJUSTMENT OF BACK-TENSION VOLTAGE AND BACK-TENSION FORCE**
 - 3-1. ADJUSTMENT IN PLAY OPERATION
 - 3-2. ADJUSTMENT IN FAST FORWARD OPERATION
 - 4. ADJUSTMENT OF BRAKE MECHANISM**
 - 4-1. ADJUSTMENT OF BRAKE BAND GUIDE
 - 4-2. ADJUSTMENT OF BRAKE SOLENOID
 - 4-3. ADJUSTMENT OF BRAKE BAND CONNECTOR STOPPERS
 - 4-4. ADJUSTMENT OF BRAKING TIME
 - 4-5. ADJUSTMENT OF BRAKING TORQUE
 - 5. ADJUSTMENT OF TAPE TRAVEL PATH**
 - 5-1. ADJUSTMENT OF REEL TABLE HEIGHT
 - 5-2. ADJUSTMENT OF TENSION ARMS
 - 6. WOW/FLUTTER AND SPEED VARIATION MEASUREMENT**
 - 6-1. WOW/FLUTTER MEASUREMENT
 - 6-2. SPEED VARIATION MEASUREMENT
-



1. ADJUSTMENT OF AUTO SHUT-OFF SWITCH

1. Remove the front panel. (For the procedure, refer to the section "Removal of Outer Outfits.")
2. With the front panel removed, you will see the auto shut-off mechanism near the LEFT TENSION ARM (5). (See Figure 1-1.)
3. Check that the TAPE CONTACT BAR (7) of the AUTO SHUT-OFF ARM (2), when pushed upward by a finger, stays between the OUTER TAPE GUIDE (4) and the ERASE HEAD (5).
4. Push the AUTO SHUT-OFF ARM upward by a finger again and release it to check the point where the auto shut-off mechanism is activated. You will hear a click sound when the mechanism is activated. See that the point is 5 to 7mm away from the AUTO SHUT-OFF ARM STOPPER (3). (See Figure 1-2.) If the position is not within the specified tolerance, loosen the AUTO SHUT-OFF SWITCH SCREWS (1) and adjust the AUTO SHUT-OFF SWITCH and AUTO SHUT-OFF ARM accordingly. When the adjustment is finished, push the AUTO SHUT-OFF ARM upward again and see that the ARM does not touch the OUTER TAPE GUIDE or the ERASE HEAD MOUNT.
5. Push the AUTO SHUT-OFF ARM upward again and check that the auto shut-off mechanism is activated when the TAPE CONTACT BAR is outside the TAPE PATH. (See Figure 1-3.) When you hear a click sound, the mechanism is activated.
6. The AUTO SHUT-OFF ARM does not go further when the AUTO SHUT-OFF ARM KNEE (6) hits the AUTO SHUT-OFF SWITCH or when the AUTO SHUT-OFF ARM hits the AUTO SHUT-OFF ARM STOPPER. (See Figure 1-4.) See that the TAPE CONTACT BAR of the AUTO SHUT-OFF ARM is inside the TAPE PATH before the AUTO SHUT-OFF ARM KNEE hits the AUTO SHUT-OFF SWITCH. If not, loosen the AUTO SHUT-OFF SWITCH SCREWS and adjust the AUTO SHUT-OFF SWITCH and AUTO SHUT-OFF ARM again, or bend the AUTO SHUT-OFF ARM,

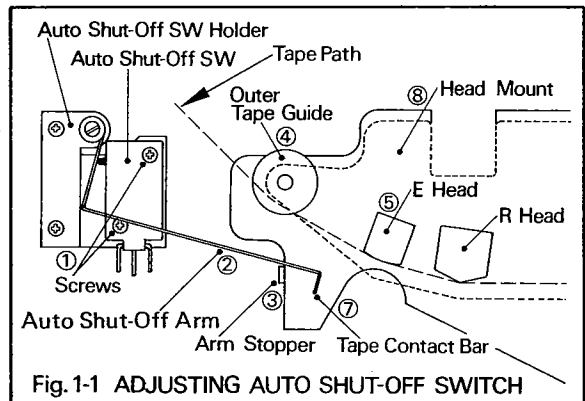

Fig. 1-1 ADJUSTING AUTO SHUT-OFF SWITCH

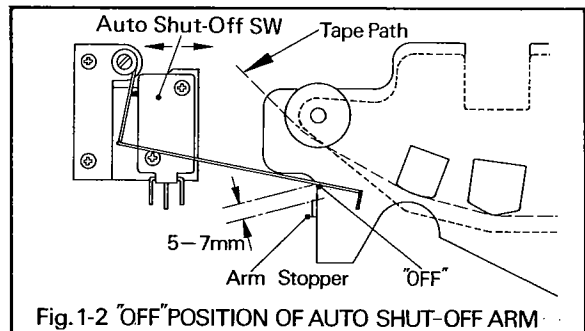

Fig. 1-2 "OFF" POSITION OF AUTO SHUT-OFF ARM

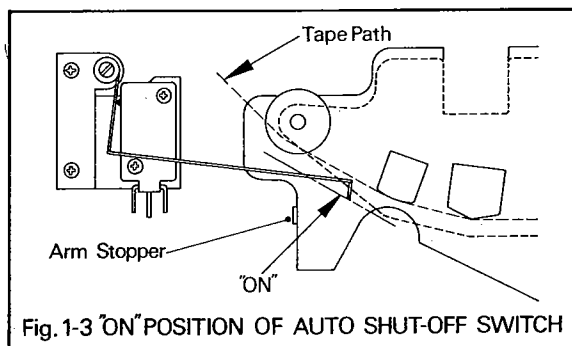

Fig. 1-3 "ON" POSITION OF AUTO SHUT-OFF SWITCH

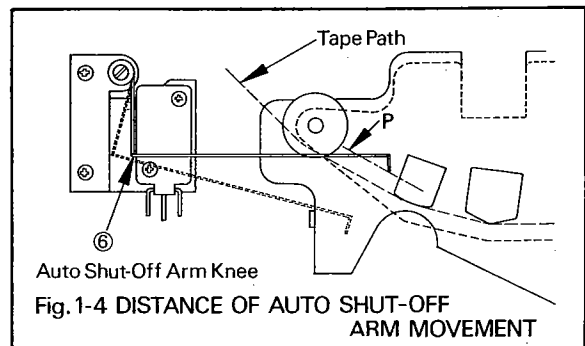
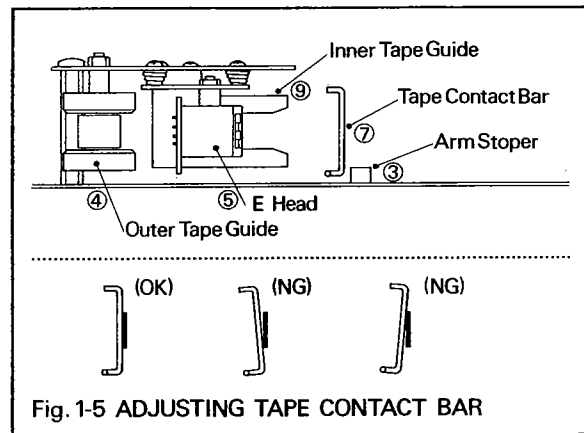

Fig. 1-4 DISTANCE OF AUTO SHUT-OFF ARM MOVEMENT



- then repeat the above-mentioned steps 4 and 5.
7. When the above-mentioned adjustments are finished, check that the AUTO SHUT-OFF ARM does not touch the chassis or head mount, or override the AUTO SHUT-OFF ARM STOPPER; when it contacts the AUTO SHUT-OFF ARM STOPPER, it must be approximately at the middle point of the AUTO SHUT-OFF ARM height. If not, bend the AUTO SHUT-OFF ARM and adjust accordingly.
 8. Now mount the front panel. Check that, by pushing the AUTO SHUT-OFF ARM upward, the TAPE CONTACT BAR, now seen through the hole, does not touch or strike the front panel.
 9. Mount a tape-loaded reel on the LEFT REEL TABLE (3) and an empty reel on the RIGHT REEL TABLE (32), fasten the clamps and thread the tape. Be sure there is no tape slack, and make sure that the TAPE CONTACT BAR touches the tape surface with uniform pressure. (See Figure 1-5.)
 10. Depress the POWER SWITCH (8) and then the PLAY BUTTON (46). Check that the tape runs safely, that the TAPE CONTACT BAR touches the tape surface with uniform pressure, and that the AUTO SHUT-OFF ARM does not touch the chassis or head mount. Then depress the FAST FORWARD BUTTON (47) and make the same examinations. However, if one or both of the operations are not activated, the position where the auto shut-off mechanism is activated is adjusted wrong. If this happens, repeat the above-mentioned steps.
 11. Push the FAST FORWARD BUTTON again. When the tape is completely wound on the reel on the RIGHT REEL TABLE, the AUTO SHUT-OFF ARM will come down to activate the auto shut-off mechanism.





2. ADJUSTMENT OF PINCH ROLLER MECHANISM

PREPARATIONS

1. Remove the front panel and the rear panel. (For the procedure, refer to the section "Removal of Outer Outfits.")
2. Push the AUTO SHUT-OFF ARM upward until a click sound is heard and fix it on the chassis with adhesive tape.

2-1. ADJUSTMENT OF PINCH ROLLER STROKE

1. Depress the PLAY BUTTON (46).
2. Set the PAUSE SWITCH (9) into the ON position. Push the PINCH ROLLER upward, making it touch the CAPSTAN, and mark with a pencil on the PINCH PRESSURE SOLENOID PLUNGER. (See Figure 2-1.)
3. Set the PAUSE SWITCH into the OFF position, engaging the tape transport in the PLAY operation. Mark again on the PINCH PRESSURE SOLENOID PLUNGER. Then check that the distance (stroke) between the two pencil marks is between 0.5mm and 1.0mm. If the distance is larger than the specified tolerance, turn the ADJUSTING NUT (A) clockwise. If it is smaller, turn it counterclockwise.
4. When the adjustment is finished, turn the LOCKING NUT (B) clockwise to fix the ADJUSTING NUT.

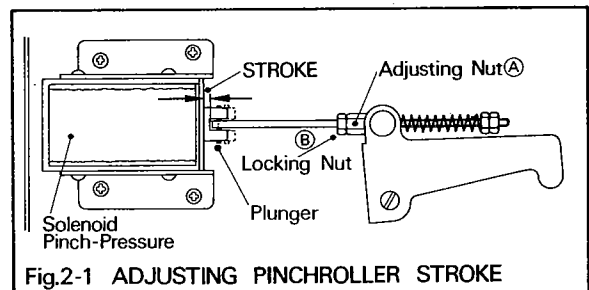

2-2. ADJUSTMENT OF PINCH ROLLER PRESSURE

Necessary equipment: A spring scale that can measure up to 2.0kg.

1. Depress the PLAY BUTTON (46).
2. Hook the scale on the PINCH ROLLER DRIVE ARM and pull the scale in the opposite direction until the PINCH ROLLER loses contact with the CAPSTAN. (See Figure 2-2.) The reading (pressure) on the scale at that moment should be about 1.5kg.
3. If the actual reading is not within a reasonable tolerance, adjust the pressure by turning the ADJUSTING NUT (A) clockwise or counterclockwise.
4. When the adjustment is over, fix the ADJUSTING NUT by the LOCKING NUT (B).

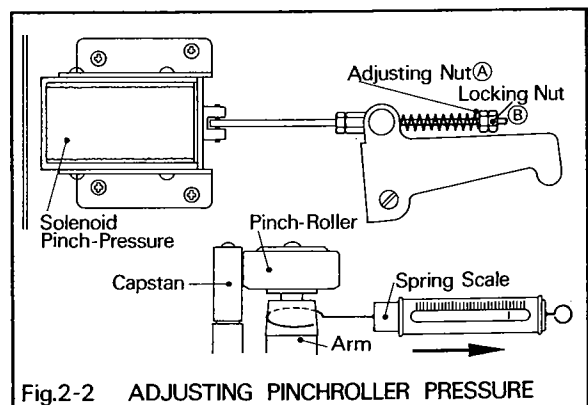



—2-3. ADJUSTMENT OF PRESSURE SWITCH

1. Depress the PLAY BUTTON (46) and the STOP BUTTON (45) repeatedly, and check that the PRESSURE SWITCH ACTUATOR ARM on the PINCH ROLLER ARM moves up and down properly.
2. Loosen the PRESSURE SWITCH SCREWS and adjust the position of the PRESSURE SWITCH, so that the PRESSURE SWITCH ACTUATOR ARM, when pushed upward in the PLAY operation, is parallel to the PRESSURE SWITCH. (See Figures 2-3 (A), (B) & (C).)
3. When the adjustment is over, first confirm that the tape transport is in the STOP operation and then push the PINCH ROLLER ARM upward slowly until a click sound is heard; the sound should be not too hard or too light, but just right. Then by pushing up and down the PINCH ROLLER ARM repeatedly, check that the PRESSURE SWITCH ACTUATOR ARM touches the PRESSURE SWITCH with soft clicks and with appropriate pressure.

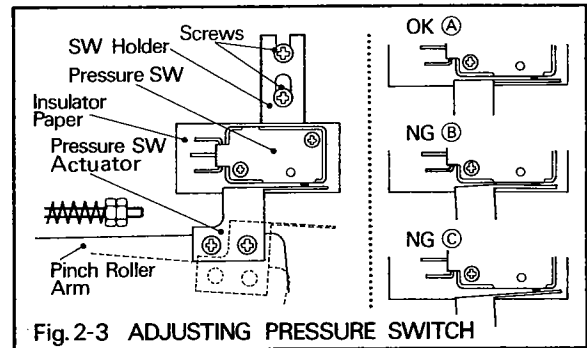

—2-4. ADJUSTMENT OF PINCH ROLLER PUSH-UP SOLENOID

1. Reprress the PLAY BUTTON (46) and the STOP BUTTON (45) repeatedly, and check that the PINCH ROLLER moves up and down properly.
2. When the PUSH-UP SOLENOID is activated, the PINCH ROLLER rises. (Indicated (A) in Figure 2-4.) When it is released, the PINCH ROLLER goes down. (Indicated (B) in Figure 2-4.) The distance that the PINCH ROLLER ARM travels is shown as (C) in Figure 2-4. If the pinch roller drive mechanism should hit the head mount, loosen the PUSH-UP SOLENOID SCREWS and move the PUSH-UP SOLENOID to the left to shorten the excursion. (See Figure 2-6.) If the pinch roller drive mechanism should strike the PINCH ROLLER GUIDE, move the PUSH-UP SOLENOID to the right to lengthen the excursion. (See Figure 2-5.)
3. When the adjustment is over, reduce the primary source voltage by 10%, and check that the PINCH ROLLER moves up and down smoothly when the PLAY BUTTON and STOP BUTTON are depressed repeatedly.

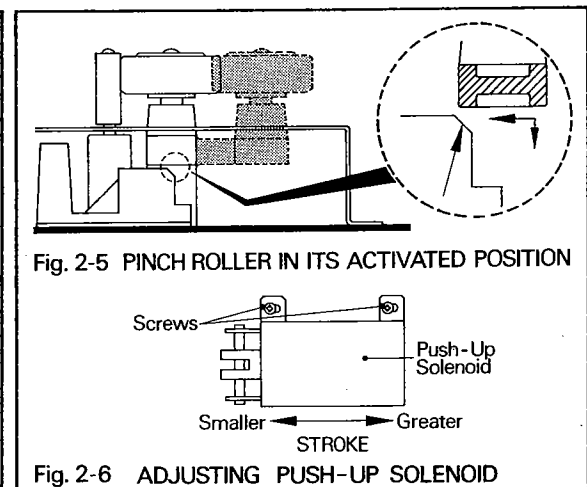
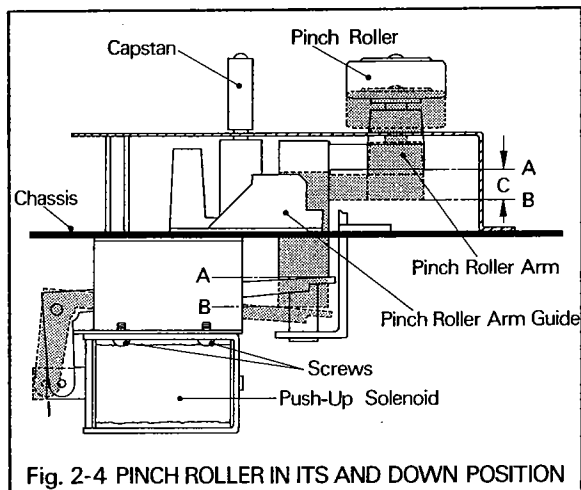



—2-5. ADJUSTMENT OF PUSH-UP SWITCH—

1. Depress the PLAY BUTTON (46) and the STOP BUTTON (45) repeatedly, and check that the PUSH-UP SWITCH ACTUATOR moves the PINCH ROLLER up and down properly, activating and de-activating the PINCH ROLLER SOLENOID. (See Figure 2-7.)
2. If the PUSH-UP SWITCH ACTUATOR contacts the PINCH ROLLER with too much pressure or touches the head mount, adjust it by bending the PUSH-SWITCH ACTUATOR.
3. When the adjustment is finished, first confirm that the mechanism is in the STOP operation and then push the PUSH-UP SWITCH ACTUATOR slowly until a click sound is heard; the sound should be not too hard or too light, but just right. Check that the PUSH-UP SWITCH ACTUATOR touches the PUSH-UP SWITCH with soft clicks and with appropriate pressure.

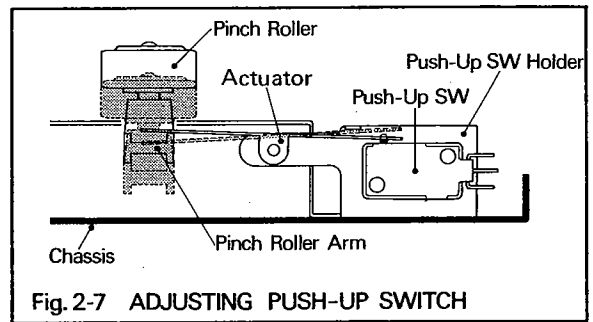

Fig. 2-7 ADJUSTING PUSH-UP SWITCH



3. ADJUSTMENT OF BACK-TENSION VOLTAGE AND BACK-TENSION FORCE

PREPARATIONS

1. Adjust the power supply voltage with the voltage regulator so that it is as specified for the tape deck.
2. Remove the rear panel. (For the procedure, refer to the section "Removal of Outer Outfits.")
3. Push the AUTO SHUT-OFF ARM upward until a click sound is heard and fix it on the chassis with adhesive tape.

Necessary equipment: Voltage regulator, tester, spring scale, 7-inch empty reel with small hub.

—3-1. ADJUSTMENT FOR PLAY OPERATION—

1. Depress the PLAY BUTTON (46).
2. Loosen the SLIDER LOCKING NUT on the green-coded cable (indicated (A) in Figure 3-1) and move the RESISTOR SLIDER back and forth on the 1200-ohm, 20-watt wirewound RESISTOR, mounted on the chassis, until the back-tension voltage, when measured by the tester between two points of the supply reel motor (PCM-219: between 2, 3 or 9, and 17, 18, 19 or 32), equals 47V (AC).
3. When the adjustment of the back-tension voltage is finished, depress the STOP BUTTON (45), mount the empty reel on the LEFT REEL TABLE (2), clamp it, hook the spring scale on the reel, and measure the back-tension force. (See Figure 3-2.) The tension force should be between 200g-cm and 250g-cm. If the measured force is not within the specified tolerance, repeat the above-mentioned steps 1 and 2. In this case, the back-tension voltage may not necessarily be 47V (AC) as shown in Fig. 3-1.
4. When the adjustment of the back-tension force is finished, tighten the SLIDER LOCKING NUT.

—3-2. ADJUSTMENT FOR FAST FORWARD OPERATION—

1. Depress the FAST FORWARD BUTTON (47).
2. Loosen the SLIDER LOCKING NUT on the white-coded cable (indicated (B) in Figure 3-1) and move the RESISTOR SLIDER back and forth on the 1200-ohm, 20-watt wirewound RESISTOR, mounted on the chassis, until the back-tension voltage, when measured by the tester between two points of the supply reel motor (PCM-219: between 2, 3 or 9, and 17, 18, 19 or 32), equals 20V (AC).
3. When the adjustment of the back-tension voltage is finished, depress the STOP BUTTON (45), mount the empty reel on the LEFT REEL TABLE (2), clamp it, hook the spring scale on the reel, and measure the back-tension force. (See Figure 3-2.) The tension force should be between 100g-cm and 130g-cm. If the measured force is not within the specified tolerance, repeat the above-mentioned steps 1 and 2. In this case, the back-tension voltage may not necessarily be 20V (AC) as shown in Fig. 3-1.
4. When the adjustment of the back-tension force is finished, tighten the SLIDER LOCKING NUT.

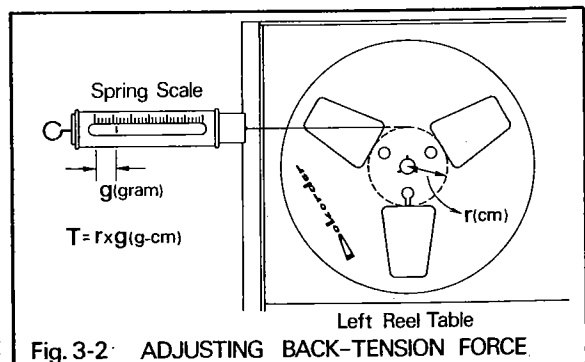
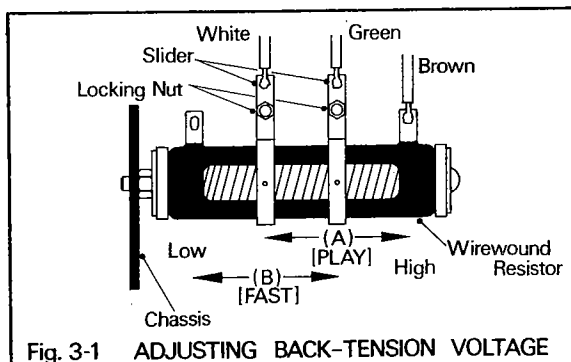



4. ADJUSTMENT OF BRAKE MECHANISM

PREPARATIONS

1. Adjust the power supply voltage with the voltage regulator so that it is as specified for the tape deck.
2. Remove the front panel. (For the procedure, refer to the section "Removal of Outer Outfits.")
3. Push the AUTO SHUT-OFF ARM upward until a click sound is heard and fix it on the chassis with adhesive tape.

Necessary equipment: Slide calipers, voltage regulator, tester, tape-loaded 7-inch reel with small hub, 7-inch empty reel with small hub.

4-1. ADJUSTMENT OF BRAKE BAND GUIDE

1. Depress the PLAY BUTTON (46) and the STOP BUTTON (45) repeatedly, and check that the BRAKE BAND moves properly between the BRAKE DRUM and the BRAKE BAND GUIDE.
2. Loosen the BAND GUIDE SCREW and adjust the BAND GUIDE so that the distance between the BRAKE BAND and the BRAKE BAND GUIDE (indicated (A) in Figure 4-1) is about 1mm when the BRAKE BAND is pressed to the BRAKE DRUM in the STOP operation. Depress the PLAY BUTTON, and check that the BRAKE SHOE does not scrape the BRAKE DRUM when the BRAKE BAND is pressed away from the BRAKE DRUM toward the BRAKE BAND GUIDE in the PLAY operation.

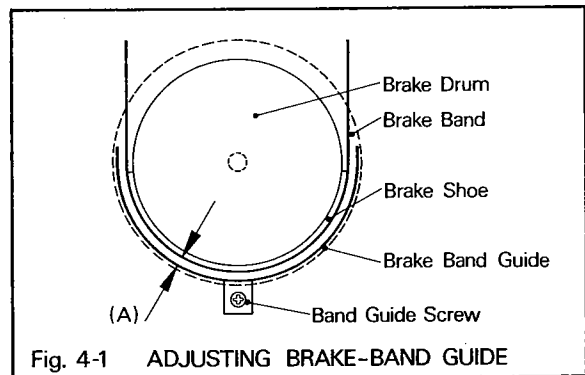

Fig. 4-1 ADJUSTING BRAKE-BAND GUIDE

the BRAKE DRUM toward the BRAKE BAND GUIDE in the PLAY operation.

4-2. ADJUSTMENT OF BRAKE SOLENOID

1. Depress the PLAY BUTTON (46) and the STOP BUTTON (45) repeatedly, and check that the BRAKE SOLENOID is activated and de-activated properly.
2. Mark with a pencil on the BRAKE SOLENOID PLUNGER when the tape transport is in the STOP operation, i.e. when the BRAKE SOLENOID is not activated. Then push the PLAY BUTTON, i.e. activate the BRAKE SOLENOID, and mark again on the BRAKE SOLENOID PLUNGER. Measure the distance between two pencil marks (Indicated (A) in Figure 4-2) with the slider calipers, and check that it is about 1mm. If the measurement is not within a reasonable tolerance from the specified figure, loosen the BRAKE SOLENOID SCREWS and adjust the position of the BRAKE SOLENOID; when it is

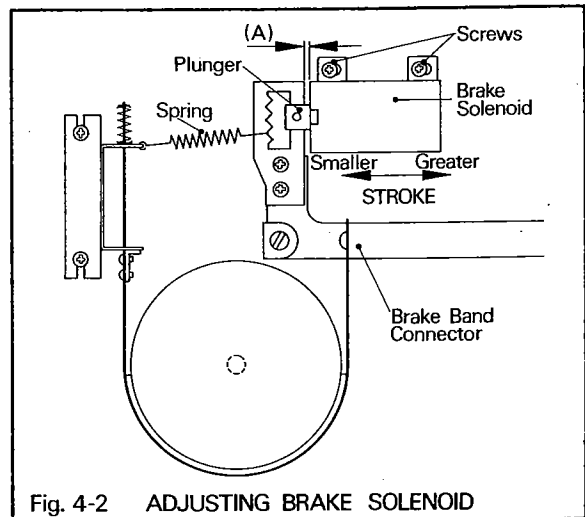

Fig. 4-2 ADJUSTING BRAKE SOLENOID



moved to the left, the distance will be smaller, and, when moved to the right, it will be greater. Be sure that the BRAKE BAND CONNECTOR does not contact or scrape the BRAKE BAND CONNECTOR GUIDE.

- When the adjustment is completed, reduce the primary source voltage by 10%, and check that the BRAKE SOLENOID is activated and de-activated smoothly even at the reduced voltage.

—4-3. ADJUSTMENT OF BRAKE BAND CONNECTOR STOPPERS—

- Depress the PLAY BUTTON (46) and the STOP BUTTON (45) repeatedly, and check that the BRAKE BAND CONNECTOR moves up and down properly.
- Check that the BRAKE BAND CONNECTOR is about 1mm away from the BRAKE BAND CONNECTOR STOPPERS (indicated (A) and (B) in Figure 4-3) when the tape transport is in the STOP operation. When the measurement is beyond a reasonable tolerance from the specified figure, loosen the BRAKE BAND CONNECTOR STOPPER SCREWS and adjust the position of the BRAKE BAND STOPPERS.
- When the adjustment is completed, check the distance between the BRAKE BAND CONNECTOR and the BRAKE BAND CONNECTOR STOPPERS by depressing the PLAY BUTTON and the STOP BUTTON repeatedly.

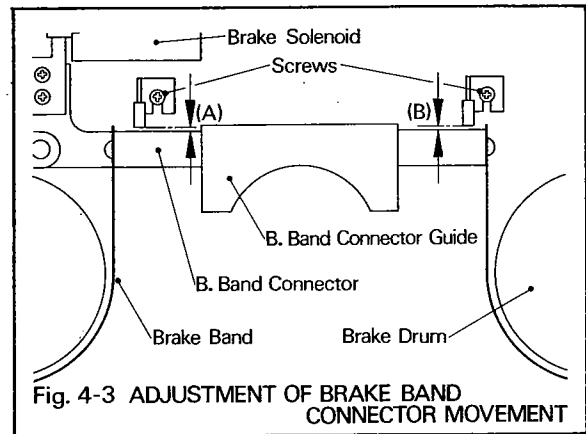

Fig. 4-3 ADJUSTMENT OF BRAKE BAND CONNECTOR MOVEMENT

—4-4. ADJUSTMENT OF BRAKING TIME—

Necessary equipment: tape-loaded 7-inch reel with small hub, 7-inch empty reel with small hub, stop watch.

- Remove the adhesive tape used to fix the AUTO SHUT-OFF ARM on the chassis.
- Mount the tape-loaded reel on the LEFT REEL TABLE (2) and the empty reel on the RIGHT REEL TABLE (32), fasten the clamps and thread the tape.
- Depress the FAST FORWARD BUTTON (47).
- Let the tape on the LEFT REEL TABLE unwind until the tape left on the reel is about 80mm across, then depress the STOP BUTTON (45). (See Figure 4-4 "FORWARD".) Check that the LEFT REEL TABLE and the RIGHT REEL TABLE stop synchronously 0.5 to 1.0 second after the STOP BUTTON is depressed. (Use the stop watch.) If the LEFT REEL TABLE stops after the RIGHT REEL TABLE, or vice versa, or if there is excessive tape slack or tension while the TABLES are coming to a halt or when the TABLES finally stop, repeat the above-mentioned adjustments of the BRAKE BAND GUIDE, BRAKE SOLENOID and BRAKE BAND CONNECTOR STOPPERS. Further, if the TABLES do not stop between 0.5 and 1.0 second after the STOP BUTTON is depressed, adjust the braking torque referring to the following section "ADJUSTMENT OF BRAKING TORQUE."

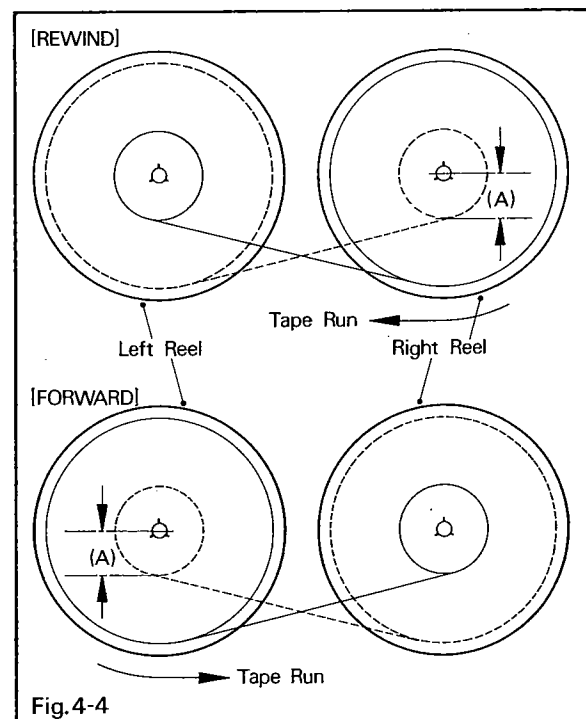

Fig. 4-4

Further, if the TABLES do not stop between 0.5 and 1.0 second after the STOP BUTTON is depressed, adjust the braking torque referring to the following section "ADJUSTMENT OF BRAKING TORQUE."



5. When the adjustment of the braking time in the FAST FORWARD operation is completed, depress the REWIND BUTTON (44).
6. Let the tape on the RIGHT REEL TABLE unwind until the tape left on the reel is about 80mm across, then depress the STOP BUTTON (45). (See Figure 4-4 "REWIND".) Check that the LEFT REEL TABLE and the RIGHT REEL TABLE stop synchronously 0.5 to 1.0 second after the STOP BUTTON is depressed. (Use the stop watch.) If the LEFT REEL TABLE stops after the RIGHT REEL TABLE, or vice versa, or if there is excessive tape slack or tension while the TABLES are coming to a halt or when the TABLES finally stop, repeat the above-mentioned adjustments of the BRAKE GUIDE, BRAKE SOLENOID and BRAKE BAND CONNECTOR STOPPERS. Further, if the TABLES do not stop between 0.5 and 1.0 second after the depression of the STOP BUTTON, adjust the braking torque referring to the following section "ADJUSTMENT OF BRAKING TORQUE."

—4.5. ADJUSTMENT OF BRAKING TORQUE—

Necessary equipment: tape-loaded 7-inch reel with small hub, 7-inch empty reel with small hub, spring scale that can measure up to 5kg.

1. Depress the STOP BUTTON (45) to make sure that the tape transport mechanism is in the STOP operation.
2. Mount the empty reel on the LEFT REEL TABLE (2) and clamp it.
3. Hook the spring scale on the reel and pull it upward until the LEFT REEL TABLE starts to turn. (See Figure 4-5.) The reading (braking torque) on the scale at that moment should be between 2.0 and 2.5kg-cm. If the actual reading is not within a reasonable tolerance; adjust the braking torque by re-positioning the BRAKE SPRING. (See Figure 4-6.) When the BRAKE SPRING is re-positioned from its original tooth to one of the upper teeth, the torque will be greater; when it is re-positioned to one of the lower teeth, the torque will be smaller.
4. Then proceed to the adjustment of the braking torque of the RIGHT REEL TABLE (32) referring to the above-mentioned steps 2 and 3. (See Figure 4-5.)
5. If an unreasonably wide difference is found between the torques for the LEFT REEL TABLE and the RIGHT REEL TABLE, adjust the BRAKE BAND GUIDE so that identical forces may be applied to the LEFT and RIGHT REEL DRUMS.
6. Remove the adhesive tape fixing the AUTO SHUT-OFF ARM on the chassis. Mount the tape-loaded reel on the LEFT REEL TABLE and the empty reel on the RIGHT REEL TABLE, fasten the clamps and thread the tape.
7. Depress the FAST FORWARD BUTTON (47) and the STOP BUTTON repeatedly, and check that the LEFT and RIGHT REEL TABLES stop synchronously in the STOP operation. If they do not stop within a reasonable delay after the depression of the STOP BUTTON, the braking torque is weak; re-position the BRAKE SPRING into one of the upper teeth.
8. Depress the REWIND BUTTON (44) and the STOP BUTTON repeatedly, and then proceed to the adjustment of the braking torque in the REWIND operation referring to the above-mentioned step 7.

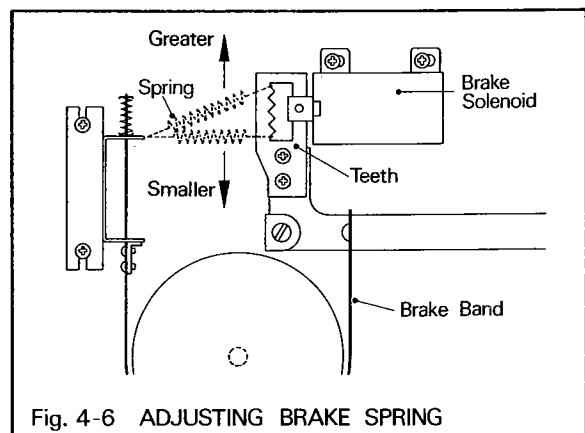
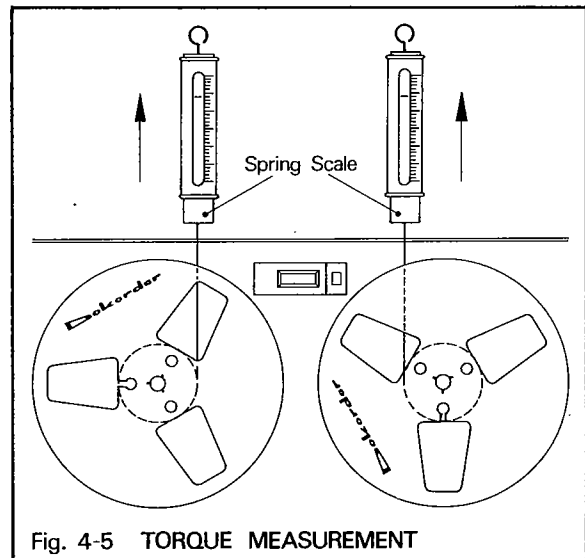



5. ADJUSTMENT OF TAPE TRAVEL PATH

PREPARATIONS

Remove the front panel. (For the procedure, refer to the section "Removal of Outer Outfits.")

Necessary equipment: Scotch Test Tape #212, 7-inch empty reel with small hub.

5-1. ADJUSTMENT OF REEL TABLE HEIGHT

1. Mount the Scotch Test Tape #212 on the LEFT REEL TABLE (2) and the empty reel on the RIGHT REEL TABLE (32), fasten the clamps and thread the tape.
2. Depress the PLAY BUTTON (46).
3. Check that the tape does not scrape the upper or lower flange of either reel.
4. If the tape scrapes the flange of either or both of the reels, depress the STOP BUTTON (45), loosen the clamps of the LEFT and RIGHT REEL TABLES and remove both reels. Then remove the LOCKING SCREW (indicated ① in Figure 5-1) of the REEL TABLE in question with a cross-headed screwdriver.
5. With the LOCKING SCREW removed, you will see the minus head of the PINION GEAR-COUPLED SCREW ②. (Since the SCREW is made of fragile material, be sure to use the screwdriver that best fits the screw-head.) If the tape has scraped the upper flange of the reel, the REEL TABLE height must be raised. Holding the CLAMP FIN ⑥, turn the PINION GEAR-COUPLED SCREW counterclockwise. On the contrary, if the tape has scraped the lower flange of the reel, the REEL TABLE height must be lowered. Turn the PINION GEAR-COUPLED SCREW clockwise. (For further details, refer to the section "CONSTRUCTION AND ADJUSTMENT OF THE REEL TABLES.")
6. When the adjustment of the REEL TABLE heights is over, fasten the PINION GEAR-COUPLED SCREW with the LOCKING SCREW again.
7. Repeat the above-mentioned step 1. Depress the PLAY BUTTON and check that the tape does not scrape the upper or lower flange of either reel now. Repeat the procedure until the appropriate REEL TABLE height is found. Should the REEL TABLE height be found unadjustable by turning the PINION GEAR-COUPLED SCREW, the tape deck must be brought to the nearest AUTHORIZED DOKORDER SERVICE DEPOT.

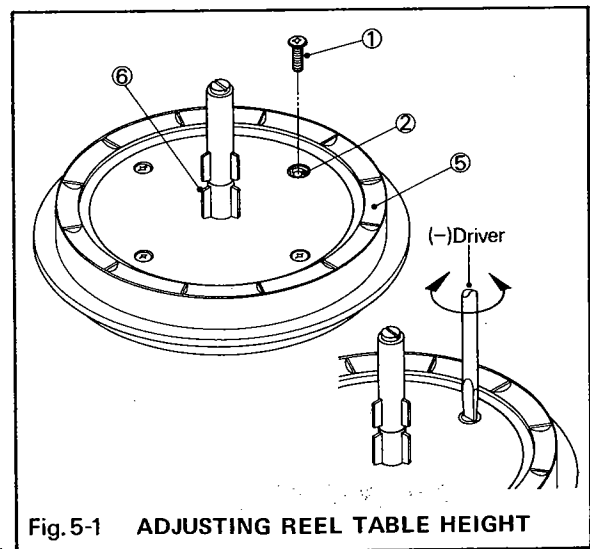

Fig. 5-1 ADJUSTING REEL TABLE HEIGHT

5-2. ADJUSTMENT OF TENSION ARMS

Necessary equipment: slide calipers.

1. Measure with the slide calipers the distance between the chassis and the head of the LEFT TENSION ARM (indicated (A) in Figure 5-2). If the distance is more than 51mm, bend the LEFT TENSION ARM so that it will be less than 50mm. Take extra care not to break it. After the adjustment, check that it does not scrape the HEAD MOUNT (8) and that its TAPE CONTACT BAR (7) indicated in Fig. 1-1 is vertical to the chassis.



2. Then Mount the Scotch Test Tape #212 on the LEFT REEL TABLE (2) and the empty reel on the RIGHT REEL TABLE (32), fasten the clamps and thread the tape.
3. Depress the PLAY BUTTON (46) and see if the tape is running at the proper height across the INNER TAPE GUIDE (9) and if the tape is not scraping either flange of the reel on the RIGHT REEL TABLE (32). If not, bend the RIGHT TENSION ARM (indicated (B) in Figure 5-2) and adjust. The difference in height between the heads of the LEFT TENSION ARM and the RIGHT TENSION ARM must not be greater than 1mm.

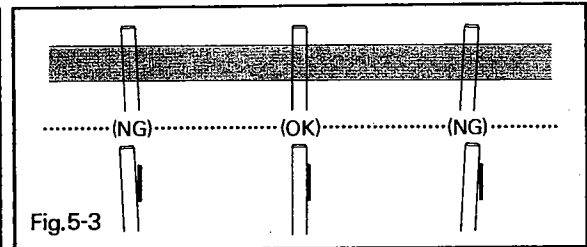
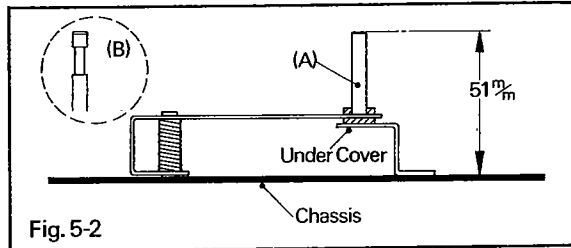



6. WOW/FLUTTER AND SPEED VARIATION MEASUREMENT

NOTE

The measurement should be made according to the NAB curve. Therefore, it is possible that the measured figures are different from the figures quoted below if the measurements are made according to a non-NAB curve or on a different wow/flutter meter. (Factory measurements are made on a Meguro MK-668A with a built-in frequency counter.)

Necessary equipment: Ampex Test Tapes 01-31336-01 for 3-3/4 ips and 01-31326-01 for 7-1/2 ips, 7-inch empty reel with small hub, wow/flutter meter, frequency counter.

6-1. WOW/FLUTTER MEASUREMENT

1. Connect the wow/flutter meter to the outputs of the tape deck. (See Figure 6-1.)
2. Turn the switch of the wow/flutter meter to the effective position and set the measurable range to 0.3%.
3. Mount the Ampex Test Tape 01-31336-01 on the LEFT REEL TABLE (2) and the empty reel on the RIGHT REEL TABLE (32), fasten the clamps, thread the tape, and set the TAPE SPEED SWITCH (4) to the 3-3/4 ips (9.5cm/sec.) position.
4. Depress the PLAY BUTTON (46).
5. Measure the wow/flutter figure at the beginning of the winding and at the end of the winding. The measured effective wow/flutter should be less than 0.20%.
6. When the measurement is completed, rewind the tape completely. Then remove the Ampex Test Tape 01-31336-01 from the LEFT REEL TABLE, loading it with the Ampex Test Tape 01-31326-01 this time. Now set the TAPE SPEED SWITCH to the 7-1/2 ips (19cm/sec.) position.
7. Repeat the above-mentioned steps 3 and 5. The measured effective wow/flutter should be less than 0.15%.

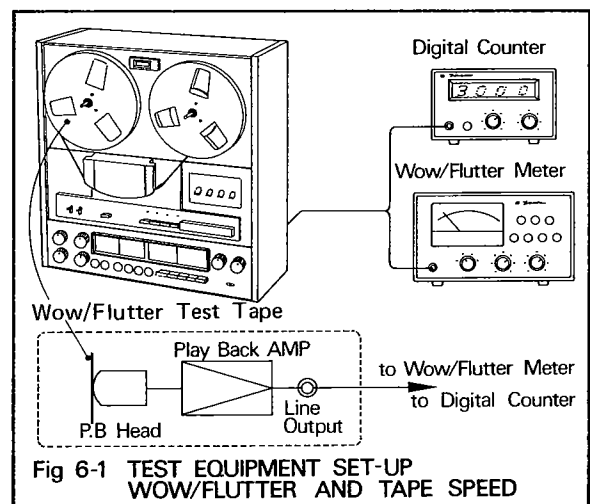

6-2. SPEED VARIATION MEASUREMENT

1. Connect the frequency counter to the outputs of the tape deck. (See Figure 6-1.)
2. Follow the above-mentioned steps 3 through 7. Measure the speed variation this time. The variation at 3-3/4 ips should be +2.5% or -2.0% at 3,000Hz; at 7-1/2 ips, it should be $\pm 2.0\%$ at 3,000Hz.



MEASUREMENT, ADJUSTMENT AND CHECKING PROCEDURES — ELECTRICAL —

TABLE OF CONTENTS

1. ADJUSTMENT AND CHECKING OF SOURCE GAIN
 - 1-1. ADJUSTMENT OF SOURCE GAIN
 - 1-2. CHECKING OF SOURCE FREQUENCY RESPONSE
 - 1-3. CHECKING OF MIC GAIN
 - 1-4. CHECKING OF MIC NOISE LEVEL
 - 1-5. ADJUSTMENT OF LEVEL METERS
 - 1-6. CHECKING OF HEADPHONE OUTPUT

 2. ADJUSTMENT AND CHECKING OF TAPE MONITOR CIRCUITS
 - 2-1. ADJUSTMENT OF PLAYBACK OUTPUT LEVEL
 - 2-2. ADJUSTMENT OF PLAYBACK FREQUENCY RESPONSE (7½ips)
 - 2-3. ADJUSTMENT OF PLAYBACK FREQUENCY RESPONSE (3¾ips)
 - 2-4. CHECKING OF LOW-FREQUENCY RESPONSE
 - 2-5. CHECKING OF PLAYBACK SIGNAL-TO-NOISE RATIO

 3. ADJUSTMENT AND CHECKING OF RECORDING CIRCUITS
 - 3-1. ADJUSTMENT OF BIAS OSCILLATOR FREQUENCY
 - 3-2. ADJUSTMENT OF RECORDING AMPLIFIER BIAS TRAP
 - 3-3. ADJUSTMENT OF AMPLIFIER BIAS TRAP
 - 3-4. ADJUSTMENT OF DUMMY COILS
 - 3-5. ADJUSTMENT OF RECORDING BIAS
 - 3-6. ADJUSTMENT OF RECORDING GAIN
 - 3-7. ADJUSTMENT RECORD/PLAYBACK FREQUENCY RESPONSE
(7½ips and 3¾ips)
 - 3-8. CHECKING OF LOW-FREQUENCY RESPONSE IN RECORD/PLAYBACK
OPERATION
 - 3-9. CHECKING OF RECORD/PLAYBACK SIGNAL-TO-NOISE RATIO

 4. ELECTRICAL ADJUSTMENT CHART
-



— LOCATION OF MEASURING PRESET POTENTIOMETERS AND COILS —

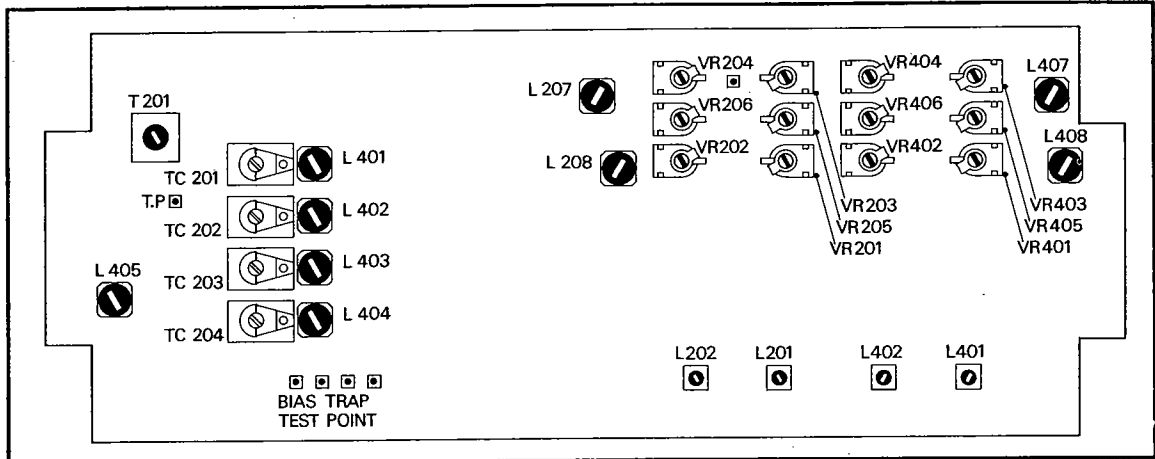

PCM-202C YG-461F (CONTROL PC BOARD)

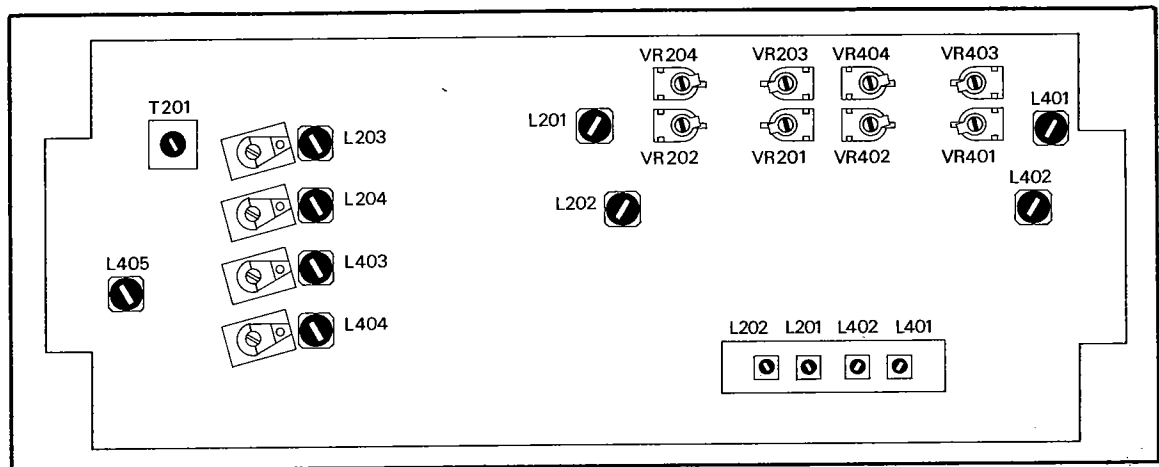

PCM-202B YG-461F (CONTROL PC BOARD)

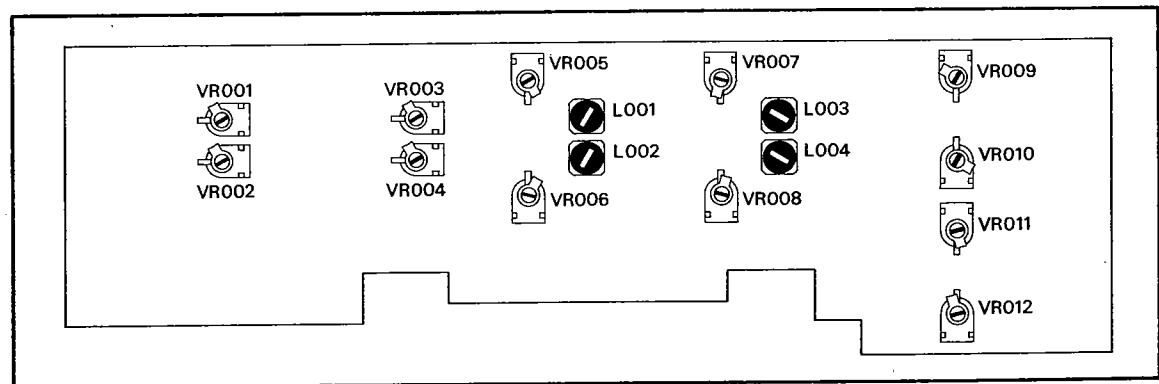

PCM-201B (AMP PC BOARD)

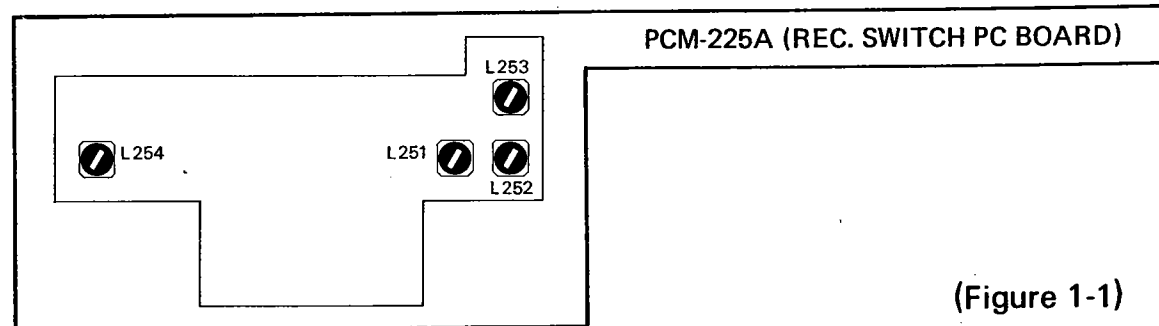

(Figure 1-1)



1. ADJUSTMENT AND CHECKING OF SOURCE GAIN

PRECAUTIONS

- Before attempting the adjustment of the electrical circuits of the tape deck, set the power voltage and frequency of the tape deck to the respective power voltage and frequency of your area. To change the voltage and/or frequency, refer to the section "VOLTAGE AND FREQUENCY CHANGE-OVER PROCEDURE". Take note that the change-over is possible only with the decks of the Universal Type that are equipped with the change-over sockets.
- When the power voltage and frequency of the tape deck are adjusted, first clean and demagnetize the heads. For the cleaning and demagnetizing procedures, refer to the sections "CLEANING" and "DEMAGNETIZING".
- Necessary equipment for adjustment and measurement (test tape, measuring apparatus, etc.) must be the type specified in each section or equivalent to the specified apparatus.

1-1. ADJUSTMENT OF SOURCE GAIN

1. Before attempting to adjust the source gain of the tape deck, set its switches and control buttons to the positions as instructed below.
 - Turn all four MIC RECORD LEVEL CONTROLS (17) (18) (21) (22) fully counter-clockwise.
 - Turn the SOUND-ON-SOUND/ECHO RECORD LEVEL CONTROL (60) fully counter-clockwise.
 - Set the MODE SWITCH (54) to the 4-channel position.
 - Set all four MONITOR SWITCHES (55) (56) (57) (58) to the source position.
 - Turn all four PLAYBACK LEVEL CONTROLS (50) (51) (52) (53) fully clockwise.
 - Turn all four LINE RECORD LEVEL CONTROLS (19) (20) (23) (24) fully clockwise.
2. Connect the measuring apparatus to the input and output jacks of the tape deck, as Figure 1-2 shows. The connections must be made first to the FRONT LEFT CHANNEL LINE INPUT JACK (72) and to the FRONT LEFT CHANNEL LINE OUTPUT JACK (68).
3. First set the frequency of the audio signal generator to 700Hz. Then observing the VTVM (Vacuum Tube Voltmeter) (1), set the attenuator so that it will indicate -20dB. Watching the VTVM (2), adjust the preset potentiometer for the front left channel VR-001 on the amplifier PC board so that it will indicate 0dB (0.775V).
4. When the adjustment of the source gain for the front left channel is completed, proceed to the adjustment of the source gain for the front right, rear left and rear right channels, following steps 2 and 3 above. Figure 1-1 shows the relationship of the preset potentiometers that need adjustment.

1-2. CHECKING OF SOURCE FREQUENCY RESPONSE

1. Follow step 1 in the preceding section "ADJUSTMENT OF SOURCE GAIN".
2. Follow step 2 in the preceding section "ADJUSTMENT OF SOURCE GAIN".
3. When the connections are finished, set the frequency of the audio signal generator to 100Hz. Observing the VTVM (1), set the attenuator so that it will indicate -20dB. Then check the VTVM (2) and see if its indication is 0dB \pm 1dB. Then set the frequency of the audio signal generator to 20kHz. Observing the VTVM (1), set the attenuator so that it will indicate -20dB. Then check the VTVM (2) and see if its indication is 0dB \pm 0.0dB.
4. When the checking of the source frequency response for the front left channel is completed, proceed to the checking of the source frequency response for the front right, rear left and rear right channels, following steps 2 and 3 above.



—1-3. CHECKING OF MIC GAIN—

1. Before attempting to check the mic gain of the tape deck, set its switches and control buttons to the positions as instructed below.
 - Turn all four MIC RECORD LEVEL CONTROLS (17) (18) (21) (22) fully clockwise.
 - Turn the SOUND-ON-SOUND/ECHO RECORD LEVEL CONTROL (60) fully counter-clockwise.
 - Set the MODE SWITCH (54) to the 4-channel position.
 - Set all four MONITOR SWITCHES (55) (56) (57) (58) to the source position.
 - Turn all four PLAYBACK LEVEL CONTROLS (50) (51) (52) (53) fully clockwise.
 - Turn all four LINE RECORD LEVEL CONTROLS (19) (20) (23) (24) fully counter-clockwise.
2. Connect the measuring apparatus to the input and output jacks of the tape deck. The connections must be made first to the FRONT LEFT CHANNEL MIC JACK (27) and to the FRONT LEFT CHANNEL LINE OUTPUT JACK (68).
3. When the connections are completed, set the frequency of the audio signal generator to 700Hz. Observing the VTVM (1), set the attenuator so that it will indicate -60dB . Then check the VTVM (2) and see if its indication is $0\text{dB} \pm 2\text{dB}$.
4. When the checking of the mic gain for the front left channel is completed, proceed to the checking of the mic gain for the front right, rear left and rear right channels, following steps 2 and 3 above.

—1-4. CHECKING OF MIC NOISE LEVEL—

1. Follow steps 1 through 3 of the preceding section "CHECKING OF MIC GAIN."
2. Pull out the plug, inserted in the FRONT LEFT CHANNEL MIC JACK. Set the measuring range of the VTVM (2) to the range of $-60\text{dB}/-50\text{dB}$. Check that the mic noise level is below -55dB .

—1-5. ADJUSTMENT OF LEVEL METERS—

1. Set all the switches and control buttons of the tape deck to the positions, following step 1 of the preceding section "ADJUSTMENT OF SOURCE GAIN."
2. When the source gain for the front left channel is completed, feed a 700Hz signal with the level of -20dB to the FRONT LEFT CHANNEL LINE INPUT JACK (72). Adjust the preset potentiometer VR-009 on the amplifier PC board, so that the level meter for the front left channel will indicate 0dB when the signal at the front left line output is measured at 0dB .
3. Then check the VTVM (2) and see if it is indicating 0dB . If not, adjust the preset potentiometer VR-001 so that the VTVM will indicate 0dB . Repeat the procedure until both the vacuum tube voltmeter and the level meter indicate 0dB .
4. When the adjustment of the level meter for the front left channel is completed, proceed to the adjustment of the level meters for the front right, rear left and rear right channels, following steps 2 and 3 above.
5. Refer to Figure 1-1 for the adjustments, related with the preset potentiometers.

—1-6. CHECKING OF HEADPHONE OUTPUT—

1. Set all the switches and control buttons of the tape deck to the positions, following step 1 of the preceding section "ADJUSTMENT OF SOURCE GAIN."
 2. First set the frequency of the audio signal generator to 700Hz. Then observing the VTVM (1), set the attenuator so that it will indicate -20dB . Feed the signal to the FRONT LEFT CHANNEL INPUT JACK (72). Check that the VTVM (2), connected to the FRONT LEFT CHANNEL LINE OUTPUT JACK (68), is indicating 0dB . Insert the plug into the FRONT CHANNEL HEADPHONE JACK (25) and check that the headphone output is $2\text{mW} \pm 0.5\text{mW}$.
-



2. ADJUSTMENT AND CHECKING OF TAPE MONITOR CIRCUITS

—2-1. ADJUSTMENT OF PLAYBACK OUTPUT LEVEL—

1. Before attempting to adjust the playback output level of the tape deck, set its switches and control buttons to the positions as instructed below.
 - Turn all four MIC RECORD LEVEL CONTROLS (17) (18) (21) (22) fully counter-clockwise.
 - Turn the SOUND-ON-SOUND/ECHO RECORD LEVEL CONTROL (60) fully counter-clockwise.
 - Set the MODE SWITCH (54) to the 4-channel position.
 - Set all four MONITOR SWITCHES (55) (56) (57) (58) to the tape position.
 - Turn all four PLAYBACK LEVEL CONTROLS (50) (51) (52) (53) fully clockwise.
 - Turn all four LINE RECORD LEVEL CONTROLS (19) (20) (23) (24) fully counter-clockwise.
2. Connect the measuring apparatus to an output jack of the tape deck.
The connection must be made first to the FRONT LEFT CHANNEL LINE OUTPUT JACK (68).
3. When the connection of the measuring apparatus is completed, load the alignment test tape (01-31321-01) on which the 700Hz signal is recorded for 15 seconds at the level of -10dB. Depress the PLAY BUTTON and set the TAPE SPEED SWITCH (4) to the 7½ips (19cm) position.
4. Adjust the preset potentiometer VR-203 on the control PC board so that the playback output level will be within 2dB above or below the -10dB level.
5. When the adjustment of the playback output level for the front left channel is completed, proceed to the adjustment of the playback output level for the front right, rear left and rear right channels, following the preceding steps 2 through 4.

—2-2. ADJUSTMENT OF PLAYBACK FREQUENCY RESPONSE (7½ips)—

1. Follow steps 1 and 2 in the preceding section "ADJUSTMENT OF PALYBACK OUTPUT LEVEL".
2. With the TAPE SELECT SWITCH still at the 7½ips (19cm) position, load the alignment tape on which the 15kHz signal is recorded at the level of -10dB.
3. Depress the PLAY BUTTON, and adjust the angle of the head so that the output of each channel is maximum when measured. The maximum tolerance of the output levels between the channels due to the azimuth difference is 2dB.
4. When the angle of the head is adjusted, adjust the preset potentiometer VR-202 so that the playback output level will be indicated within 3dB above or below the -10dB level.
5. When the adjustment of the playback frequency response for the front left channel is completed, proceed to the adjustment of the playback frequency response for the front right, rear left and rear right channels, following the preceding step 4.

—2-3. ADJUSTMENT OF PLAYBACK FREQUENCY RESPONSE (3¾ips)—

1. Follow steps 1 and 2 in the preceding section "ADJUSTMENT OF PLAYBACK OUTPUT LEVEL."
2. Load the alignment tape on which the 500Hz signal is recorded at the level of -10dB,



depress the PLAY BUTTON and set the TAPE SPEED SELECT SWITCH to the 3 $\frac{3}{4}$ ips (9.5cm) position, then read the level (standard signal level). Then load another alignment tape on which the 7.5kHz signal is recorded at the level of -10dB. Adjust preset potentiometer VR-205 so that the difference between the standard signal level and the level at 7.5kHz is within 3dB above or below the -10dB level.

3. When the playback frequency response for the front left channel is completed, proceed to the adjustment of the playback frequency response for the front right, rear left and rear right channels, following the preceding step 2.

—2.4. CHECKING OF LOW-FREQUENCY RESPONSE—

1. CHECKING OF LOW-FREQUENCY RESPONSE (7 $\frac{1}{2}$ ips or 19cm)

- Follow steps 1 and 2 in the preceding section "ADJUSTMENT OF PLAYBACK OUTPUT LEVEL."
- Load the alignment tape on which the 700Hz signal is recorded at the level of -10dB, and set the TAPE SPEED SELECT SWITCH to the 7 $\frac{1}{2}$ ips (19cm) position, then read the level (standard signal level). Then load another alignment tape on which the 50Hz signal is recorded at the level of -10dB. Check that the level at 50Hz is within +5dB above or -4dB below the standard signal level of -10dB.

2. CHECKING OF LOW-FREQUENCY RESPONSE (3 $\frac{3}{4}$ ips or 9.5cm)

- Follow steps 1 and 2 in the preceding section "ADJUSTMENT OF PLAYBACK OUTPUT LEVEL."
- Load the alignment tape on which the 500Hz signal is recorded at the level of -10dB, and set the TAPE SPEED SELECT SWITCH to the 3 $\frac{3}{4}$ ips (9.5cm) position, then read the level (standard signal level). Then load another alignment tape on which the 50Hz signal is recorded at the level of -10dB. Check that the level at 50Hz is within +5dB above or -4dB below the standard signal level of -10dB.

—2.5. CHECKING OF PLAYBACK SIGNAL-TO-NOISE RATIO—

1. Follow steps 1 and 2 in the preceding section "ADJUSTMENT OF PLAYBACK OUTPUT LEVEL."
 2. Load a blank (unrecorded) Scotch tape #212 and depress the PLAY BUTTON. Check that the signal-to-noise ratio in the PLAY mode is better than 48dB at the standard output level of 700Hz.
 3. Then proceed to the checking of the signal-to-noise ratio in the PLAY mode for the front right, rear left and rear right channels.
-



3. ADJUSTMENT AND CHECKING OF RECORDING CIRCUITS

—3-1. ADJUSTMENT OF BIAS OSCILLATOR FREQUENCY—

1. To adjust the bias oscillator frequency of the tape deck, set its switches and control buttons to the positions as instructed below.
 - Depress all four RECORD SWITCHES (13) (14) (41) (42).
 - Set the MODE SWITCH (54) to the 4-channel position.
 - Push the AUTO SHUT-OFF SWITCH (7) upward and fix it to the chassis by adhesive tape.
 - Depress the RECORD BUTTON (43) and PLAY BUTTON (46) at the same time to set the tape deck into the RECORD mode.
 - Depress the PAUSE SWITCH (9) to set the tape deck in the PAUSE mode.
2. Connect the measuring apparatus such as synchroscope to the control PC boards for adjustment as follows.
 - With the control PC board PCM-202C YG-461F, apply the probes to the test point and ground, and adjust the oscillator coil T-201 so that the bias oscillator frequency will be 130kHz \pm 5kHz.
 - With the control PC board PCM-202B YG461F, apply the probes to the pin 47 and 46 on the board and adjust the oscillator coil T-201 so that the bias oscillator frequency will be 130kHz \pm 5kHz.

—3-2. ADJUSTMENT OF RECORDING AMPLIFIER BIAS TRAP—

1. Follow step 1 in the preceding paragraph "ADJUSTMENT OF BIAS OSCILLATOR FREQUENCY."
2. Connect the measuring apparatus such as synchroscope to the control PC boards for adjustment as follows.
 - With the control PC board PCM-202C YG-461F, apply the probes to the bias trap test points and ground, and adjust each of the trap coils L-203, L-204, L-403 and L-404 so that the bias leakage at the test points may be minimum. Relationship between the test points and the bias trap coils is as follows.

TEST POINT	BIAS TRAP	
1	L-203	(FRONT LEFT)
3	L-204	(FRONT RIGHT)
2	L-403	(REAR LEFT)
4	L-404	(REAR RIGHT)

- With the control PC board PCM-202B YG-461F, apply the probes to the pin 38 and 43, 40 and 43, 42 and 43, and 44 and 43, and adjust each of the trap coils L-203, L-204, L-403 and L-404 so that the bias leakage at the pins may be minimum. Relationship between the pins and the bias trap coils is as follows.

TEST POINT	BIAS TRAP	
(38 and 43)	L-203	(FRONT LEFT)
(40 and 43)	L-204	(FRONT RIGHT)
(42 and 43)	L-403	(REAR LEFT)
(44 and 43)	L-404	(REAR RIGHT)



—3.3. ADJUSTMENT OF AMPLIFIER BIAS TRAP—

1. Follow step 1 in the preceding section "ADJUSTMENT OF BIAS OSCILLATOR FREQUENCY."
2. Connect the measuring apparatus (vacuum tube voltmeter VTVM) to the line output terminals.
3. Adjust the bias trap coils on the control PC boards PCM-202C YG-461F and PCM-202B YG-461F so that the bias leakage of each line output may be -32dB or better. The adjustment must be conducted for each channel. Relationship between the channels and the bias trap coils is as follows.

CHANNEL	BIAS TRAP ①	BIAS TRAP ②	LINE OUT	
1st channel	L-201	L-207	FRONT LEFT (68)	First Adj.
3rd channel	L-202	L-208	FRONT RIGHT (67)	Second Adj.
2nd channel	L-401	L-407	REAR LEFT (70)	Third Adj.
4th channel	L-402	L-408	REAR RIGHT (71)	Fourth Adj.

—3.4. ADJUSTMENT OF DUMMY COILS—

1. Follow step 1 in the preceding section ADJUSTMENT OF BIAS OSCILLATOR FREQUENCY.
2. Connect the measuring apparatus such as synchroscope to the control PC boards for adjustment as follows.
 - With the control PC board PCM-202C YG-461F, apply the probes to the test points and ground and adjust the dummy coils L-251, L-252, L-253 and L-254 on the record switch PC board PCM-225A by observing the oscillator frequency at the test points so that the oscillator frequency may not be affected when the RECORD SWITCHES (13) (14) (41) (42) are depressed one by one.
 - With the control PC board PCM-202B YG-461F, apply the probes to the pin 59 and 61 on the control PC board, and adjust the dummy coils L-251, L-252, L-253 and L-254 on the record switch PC board PCM-225A by observing the oscillator frequency at the pin 59 and 61 so that the oscillator frequency may not be affected when the RECORD SWITCHES (13) (14) (41) (42) are depressed one by one. Relationship between the channels and the dummy coils is as follows.

CHANNEL	DUMMY COIL	(PCM-202C YG-461F)	(PCM-202B YG-461F)
1st channel (FRONT LEFT)	L-251		
3rd channel (FRONT RIGHT)	L-252	TEST POINTS	Pins 59 and 61
2nd channel (REAR ELFT)	L-253		
4th channel (REAR RIGHT)	L-254		

3. Adjust the dummy coil L-405 on the control PC boards PCM-202C YG-461F and PCM-202B YG-461F so that the oscillator frequency may not be affected when the MODE SWITCH (54) is switched from the 2-channel position to the 4-channel and then from the 2-channel to the 4-channel.

—3.5. ADJUSTMENT OF RECORDING BIAS—

1. To adjust the recording bias of the tape deck, set its switches and control buttons to the positions as instructed below.



- Turn all four LINE RECORD LEVEL CONTROLS (19) (20) (23) (24) fully clockwise.
 - Depress all four RECORD SWITCHES (13) (14) (41) (42).
 - Turn all four PLAYBACK LEVEL CONTROLS (50) (51) (52) (53) fully clockwise.
 - Turn all four MIC RECORD LEVEL CONTROLS (17) (18) (21) (22) and the SOUND-ON-SOUND/ECHO RECORD LEVEL CONTROL (60) fully counterclockwise.
 - Set the MODE SWITCH (54) to the 4-channel position, and set all four MONITOR SWITCHES (55) (56) (57) (58) to the TAPE position.
2. Connect the measuring apparatus to the line input and output jacks and load the Scotch tape #212.
 3. Depress the RECORD BUTTON (43) and the PLAY BUTTON (46) at the same time to set the tape deck in the RECORD mode. Then set the TAPE SPEED SWITCH (3) to the 7½ips (19cm) position.
 4. Feed a 700Hz signal through the line input and adjust the trimmer capacitors on the control PC boards (PCM-202C YG-461F: TC-201, TC-202, TC-401, TC-402 and PCM-202B YG-461F: VR-205, VR-206, VR-405, VR-406) so that the line output level will be 0.2dB to 0.5dB below the maximum output. (The bias will be overbiased.)

—3-6- ADJUSTMENT OF RECORDING GAIN—

1. Follow steps 1 through 3 in the preceding paragraph "ADJUSTMENT OF RECORDING BIAS."
2. Feed a 700Hz signal at the level of -20dB to the line input and adjust the preset potentiometers VR-005, VR-006, VR-007 and VR-008 on the amplifier PC board PCM-201B so that the line output becomes 0dB.
3. Then set the TAPE SPEED SWITCH (3) to the 3¾ips (9.5cm) position, feed a 500Hz signal at the level of -20dB to the line input and check that the line output level is 0dB ±2dB. Also check that the difference between the levels of the four channels is less than 2dB.

—3-7. ADJUSTMENT OF RECORD/PLAYBACK FREQUENCY RESPONSE—

(7½ips and 3¾ips)

1. Follow steps 1 through 3 in the preceding section "ADJUSTMENT OF RECORDING BIAS."
2. Feed a 700Hz signal from the line input and set the line output level at -20dB.
3. Adjust the peaking coils L-001, L-002, L-003 and L-004 on the amplifier PC board PCM-201B so that the frequency response becomes flat. Do not forget to fine-adjust the recording bias then. The highest frequency of the recorded signal must be 20kHz ±3dB.
4. Set the TAPE SPEED SWITCH (3) to the 3¾ips (9.5cm) position, feed a 500Hz signal and set the line output level at -20dB. Check that the line output level is ±3dB at 10kHz.

—3-8. CHECKING OF LOW-FREQUENCY RESPONSE IN RECORD/PLAYBACK OPERATION—

Follow steps 1 through 4 in the preceding paragraph "ADJUSTMENT OF RECORD/PLAYBACK FREQUENCY RESPONSE (7½ips and 3¾ips)". Check that the frequency response between 50Hz and 250Hz is 0dB ±½dB.

—3-9. CHECKING OF RECORD/PLAYBACK SIGNAL-TO-NOISE RATIO—

Run the tape in the Record mode without recording a signal on the tape at the speeds of 7½ips and 3¾ips and play it back. Check that the signal-to-noise ratio is better than -46dB when the bias leakage noise is not taken into consideration.

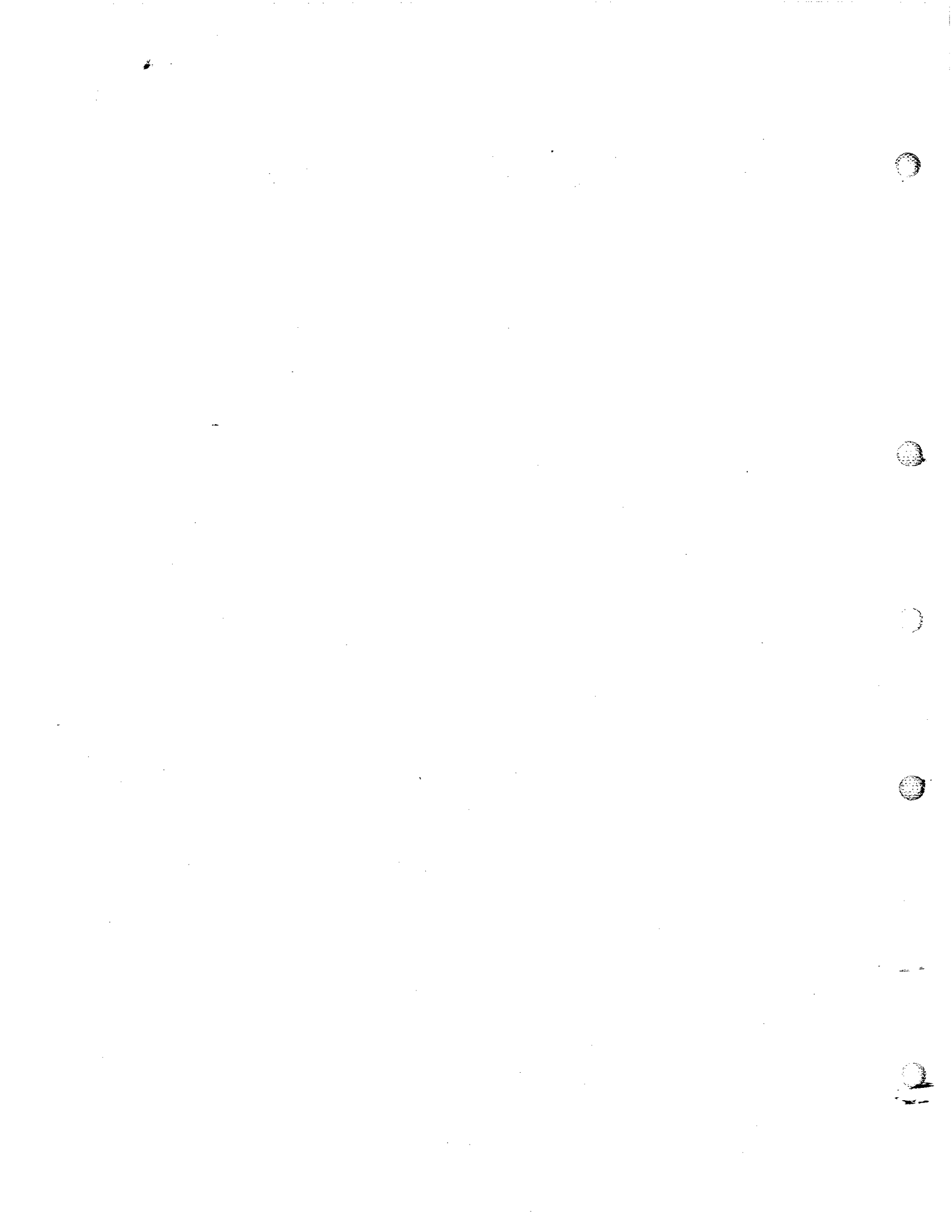

ELECTRICAL ADJUSTMENT CHART (1)

Item	Signal Source	Mode	Output Connection	Adjust	Remarks
1. Source Gain Adjustment	700Hz, -20dB to the LINE INPUT	SOURCE	VTVM to the LINE OUTPUT (FRONT CH-1, CH-3) (REAR CH-2, CH-4)	F.L CH-1 VR-001 F.R CH-3 VR-002 R.L CH-2 VR-003 R.R CH-4 VR-004 See Fig. 1-1	1. Set the LINE VR and PLAY LEVEL VR maximum, MIC VR minimum, ECHO/SOS VR minimum and MONITOR SW to SOURCE position. 2. Set the MODE SW to 4-CHANNEL position and Multi-Sync SW to NORMAL position. 3. Adjust the VR-001, VR-002, VR-003 and VR-004 to read 0dB on VTVM.
2. Meter Level Adjustment	700Hz, -20dB to the LINE INPUT	SOURCE	VTVM to the LINE OUTPUT (FRONT CH-1, CH-3) (REAR CH-2, CH-4)	F.L CH-1 VR-009 F.R CH-3 VR-010 R.L CH-2 VR-011 R.R CH-4 VR-012 See Fig. 1-1	Adjust the VR-009, VR-010, VR-011 and VR-012 so that VU meter indicators OVU.
3. Playback Head Height and Azimuth Adjustment	15KHz, AMPEX standard test tape, 01-313321-01	PLAYBACK (7½ips)	VTVM to the LINE OUTPUT (FRONT CH-1, CH-3) (REAR CH-2, CH-4)	Playback head height and azimuth adjusting screws. See Fig. 1-1	1. Set the PLAY LEVEL VR maximum, ECHO/SOS VR minimum, MIC VR minimum, LINE VR minimum and MONITOR SW to TAPE position. 2. Adjust the screws to obtain maximum reading on VTVM.
4. Playback Level Adjustment	700Hz, -10dB AMPEX standard test tape 01-313321-01	PLAYBACK (7½ips)	VTVM to the LINE OUTPUT (FRONT CH-1, CH-3) (REAR CH-2, CH-4)	F.L CH-1 VR-203 F.R CH-3 VR-204 R.L CH-2 VR-303 R.R CH-4 VR-304 See Fig. 1-1	Adjust the VR-203, VR-204, VR-403 and VR-404 to read -10dB on VTVM.
5. Playback Amplifier EQ. Adjustment	15KHz, -10dB AMPEX standard test tape 01-313321-01	PLAYBACK (7½ips)	VTVM to the LINE OUTPUT (FRONT CH-1, CH-3) (REAR CH-2, CH-4)	F.L CH-1 VR-201 F.R CH-3 VR-202 R.L CH-2 VR-401 R.R CH-4 VR-402 See Fig. 1-1	Adjust the VR-201, VR-202, VR-401 and VR-402 to read -10dB ±3dB on VTVM.
6. Playback Amplifier EQ. Adjustment	7.5KHz, -10dB AMPEX standard test tape 01-313331-01	PLAYBACK (3¾ips)	VTVM to the LINE OUTPUT (FRONT CH-1, CH-3) (REAR CH-2, CH-4)	F.L CH-1 VR-205 F.R CH-3 VR-206 R.L CH-2 VR-405 R.R CH-4 VR-406 See Fig. 1-1	Adjust the VR-205, VR-206, VR-405 and VR-406 to read -10dB ±3dB on VTVM. (Control PC Board PCM-202C only)
1. Bias OSC Frequency Adjustment		RECORD (7½ips)	Frequency Counter to the PCM-202(C) TEST POINT PCM-202(B) (47.46)	T-201 See Fig. 1-1	Adjust the T-201 so that the Frequency Counter indicates 130KHz ±5KHz.
2. Recording Amplifier Bias Trap Adjustment		RECORD (7½ips)	VTVM to the PCM-202(C)(B) (C) (B) F.L CH-1 Tp-1 (38.43) F.R CH-3 Tp-3 (40.43) R.L CH-2 Tp-2 (42.43) R.R CH-4 Tp-4 (44.43) See Fig. 1-1	F.L CH-1 L-203 F.R CH-3 L-204 R.L CH-2 L-403 R.R CH-4 L-404 See Fig. 1-1	Adjust the L-203, L-204, L-403 and L-404 to obtain minimum reading on VTVM.
3. Record Head Height and Azimuth Adjustment	15KHz, -20dB to the LINE INPUT	RECORD (7½ips)	VTVM with Lowpass Filter (cf=30KHz) to the LINE OUTPUT	Record head height and azimuth adjusting screws. See Fig. 1-1	Adjust screws to obtain maximum reading on VTVM.
4. Amplifier Bias Trap Adjustment		RECORD (7½ips)	VTVM to the LINE OUTPUT	(1) F.L CH-1 L-201 L-207 F.R CH-3 L-202 L-208 R.L CH-2 L-401 L-407 R.R CH-4 L-402 L-408 See Fig. 1-1	Adjust to obtain minimum -35dB on VTVM.
5. Dummy Coils Adjustment		RECORD (7½ips)	Frequency Counter to the PCM-202(C) TEST POINT PCM-2-2(B) (59.61)	F.L CH-1 L-251 F.R CH-3 L-252 R.L CH-2 L-253 R.R CH-4 L-254 See Fig. 1-1	Adjust the dummy coil to keep constant bias oscillator frequency when record switches are depressed one by one.

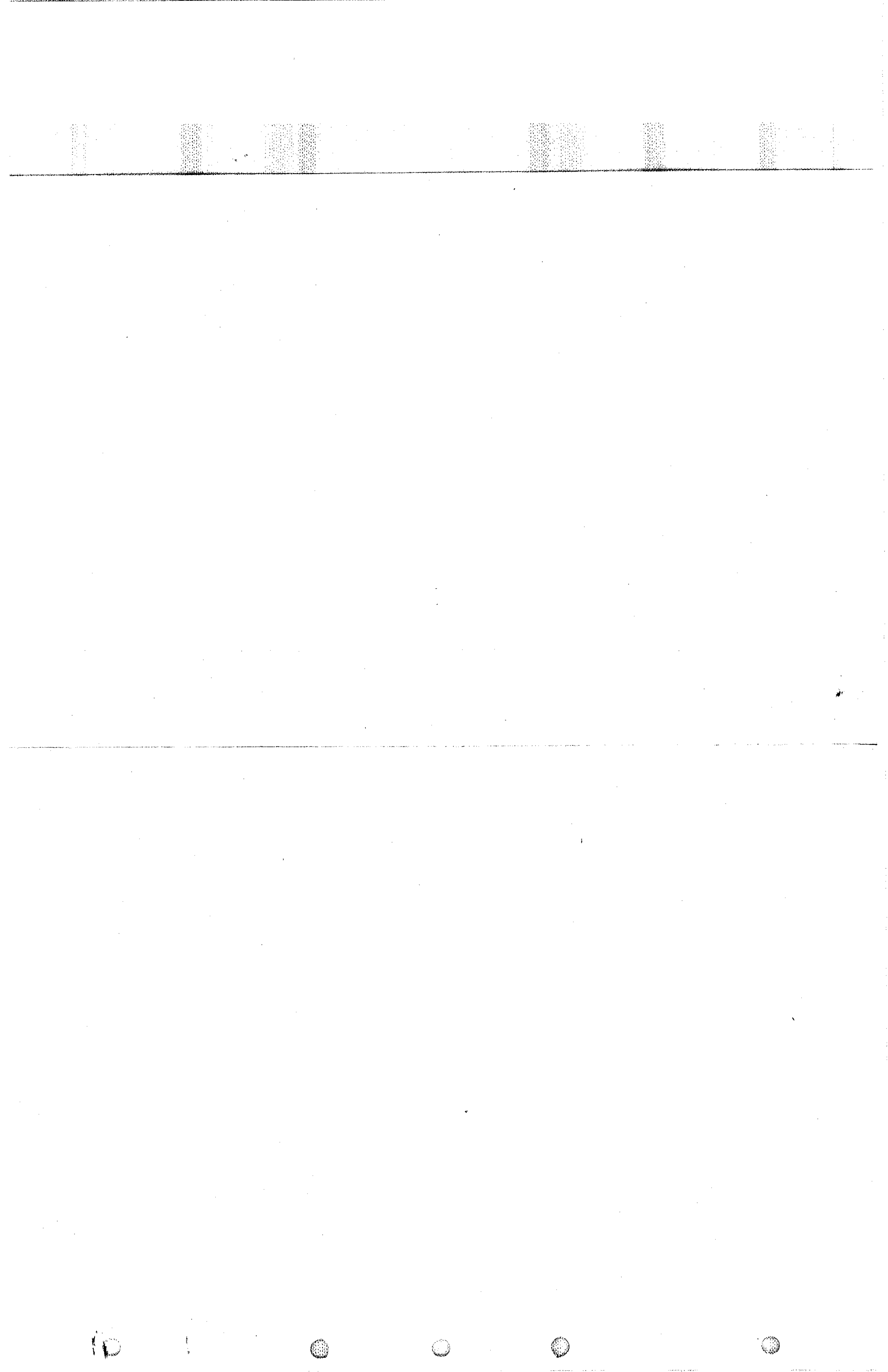

ELECTRICAL ADJUSTMENT CHART (2)

Item	Signal Source	Mode	Output Connection	Adjust	Remarks
6. Recording Bias Adjustment	700Hz, -20dB to the LINE INPUT	RECORD (7½ips)	VTVM with Lowpass Filter (cf=30KHz) to the LINE OUTPUT	(C) F.L CH-1 TC-201 F.R CH-3 TC-202 R.L CH-2 TC-401 R.R CH-4 TC-402 See Fig. 1-1 (B) VR-205 VR-206 VR-405 VR-406	1. Set the LINE VR and PLAY LEVEL VR maximum, MIC VR minimum, ECHO/SOS VR minimum and MONITOR SW to TAPE position. 2. Record 700Hz, -20dB on blank tape (SCOTCH #212 at normal and MAXELL #UD35 at special position of Tape Selector SW). 3. Adjust and set at about 0.2dB ~ 0.5dB down pass the peak reading on VTVM.
7. Recording Gain Adjustment	700Hz, -20dB to the LINE INPUT	RECORD (7½ips)	VTVM with Lowpass Filter (cf=30KHz) to the LINE OUTPUT	F.L CH-1 VR-005 F.R CH-3 VR-006 R.L CH-2 VR-007 R.R CH-4 VR-008 See Fig. 1-1	1. Record 700Hz, -20dB on blank tape (SCOTCH #212). 2. Adjust the VR-005, VR-006, VR-007 and VR-008 to read 0dB on VTVM.
8. Record Equalizer Adjustment	20KHz, -40dB to the LINE INPUT	RECORD (7½ips)	VTVM with Lowpass Filter (cf=30KHz) to the LINE OUTPUT	F.L CH-1 L-001 F.R CH-3 L-002 R.L CH-2 L-003 R.R CH-4 L-003 See Fig. 1-1	1. Record 20KHz, -40dB and adjust so that VTVM reading is same as of 700Hz signal at 7½ips (-20dB). 2. If unable to obtain flat response at high frequency (-20dB±3dB) readjust recording bias. But make sure the bias adjustment at 700Hz is set at peak or pass the peak reading on VTVM (never set bias before reaching peak point on VTVM).



PACKAGING PROCEDURES

SHIPPING INSTRUCTIONS

If the unit is to be sent back to the DOKORDER, INC. (service department) for repair, carefully pack as shown below.

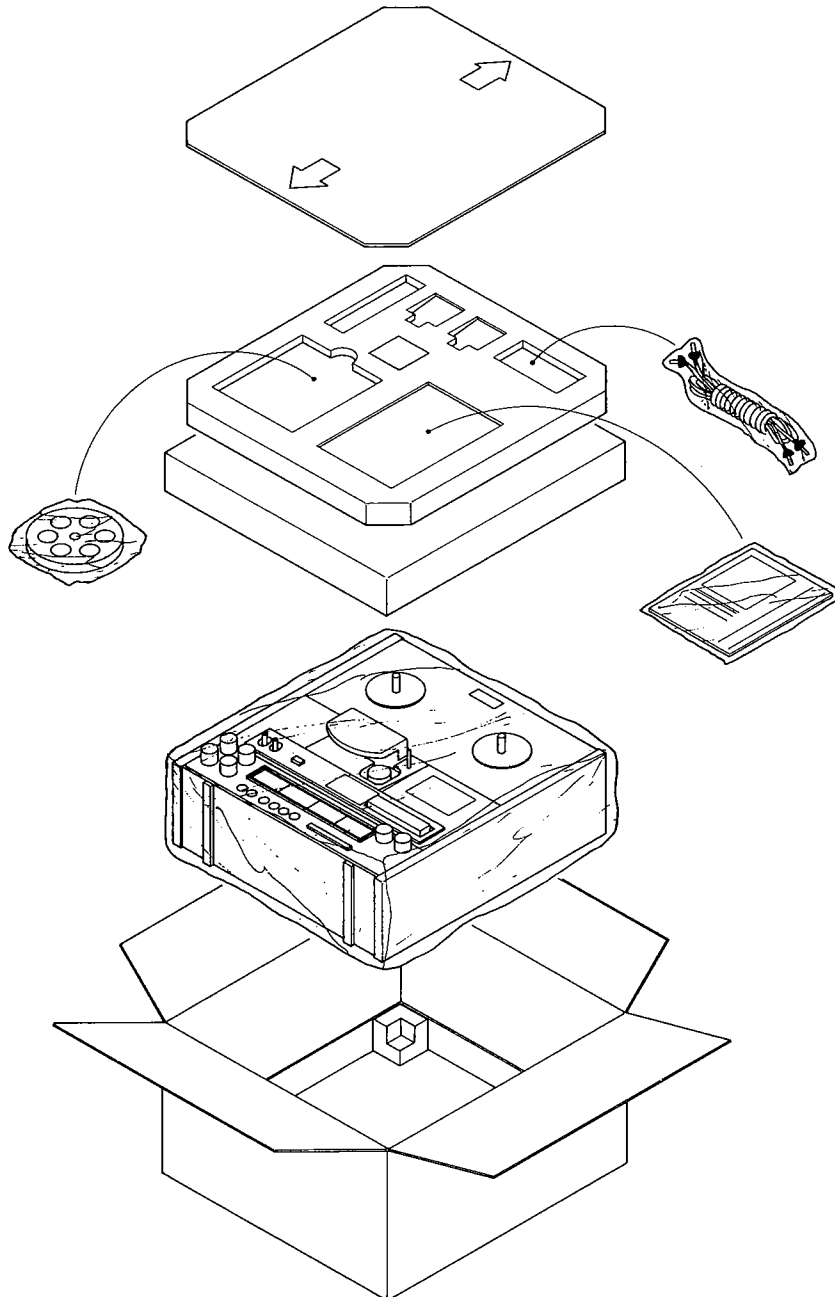



TROUBLE SHOOTING CHART

—THESE CONDITIONS DO NOT MEAN A BREAKDOWN—

CONDITION	CAUSE	REMEDY
Tape does not run.	Power cord is loose or out of AC outlet. Power fuse has blown. Pause switch is on. Auto shut-off switch is not disengaged by tape.	Insert the power cord into AC outlet firmly. Find out the cause of blow-out, and replace with a new 3A fuse. Raise pause switch, and release it. Re-thread tape properly to disengage auto shut-off switch.
Sound is unsteady or hoarse in recording or playback.	There is dirt or dust on head(s). Tape has stretched.	Clean head(s) with cleaning liquid and remove dirt or dust. Replace tape.
Reproduced sound is distorted.	Pre-recorded tape itself is distorted. Playback volume is raised too high. Tape recorder's output impedance does not match input impedance of amplifier.	If pre-recorded tape itself is distorted, there's no real remedy. Replace it with a different tape and check. Lower volume control. Check input impedance of amplifier and match it with tape recorder's output impedance, using a matching transformer if necessary.
Recorded sound is distorted.	Recording levels are too high. Amplifier and microphones have different impedances.	Adjust the level controls so that pointers of VU meters will not enter red zones. Check specifications of those instruments and match impedances*.
There is considerable wow in recording and playback.	Capstan and/or pinch roller are soiled, or there's oil on them. Tape is rubbing reel(s). Lack of lubrication, or stretched belt.	Remove dust and oil from capstan and pinch roller, using cleaning liquid. Replace reel(s) or adjust heights of reel table(s). Lubricate motor shafts, etc., or replace belt.
Loud noise.	Heads are magnetized. Tape has a high noise content. Improper contact of input and output cables.	Demagnetize with a demagnetizer. Replace with a new tape. Replace cables whose plugs are of different sizes from their sockets or are rusted.
Loud hum is heard in playback.	Input and output cables are not plugged in completely. Leakage flux from outside (induced noise from power transformer of amplifier, etc.)	Insert plugs firmly. Move source of leakage flux causing hum (such as transformers) away from tape recorder.
Does not record or reproduce when tape recorder is connected with a DIN cable.	Input/output levels do not match with those of amplifier. DIN cable is cut.	Use amplifier whose DIN socket has the correct input/output levels of DIN standard. Replace with a new DIN cable.

* A microphone either has a high impedance (from 5 kilo-ohms to 100 kilo-ohms) or a low impedance (from 50 ohms to 1 kilo-ohms).



Dokorder

Information for your Service Department
Prepared and Distributed by Dokorder Inc., Service Dept.

SERVICE MANUAL
SM-0100-00
MODEL 7140

WARRANTY

All DOKORDER stereo tape recorders are fully guaranteed against defects in material (see exceptions * below) for a period of one full year from date of original purchase, and are guaranteed against defects in workmanship for a period of ninety days from date of original purchase.

- * This Warranty does not cover cases.
- * This Warranty is void and of no effect if the serial number has been removed or altered.
- * This Warranty shall not apply to any product which has been improperly connected, used, repaired, or altered in any way which the factory believes has affected the stability or reliability of the product.
- * This Warranty is void and of no effect if the product was not purchased from a Franchised Dokorder Dealer.

If any part should prove defective within the warranty period, contact the dealer from whom the tape recorder was purchased, or an authorized DOKORDER service depot. If examination determines the part is defective in material or workmanship, the part will be replaced at no charge.

The responsibility of Denki Onkyo is limited to making new or factory reconditioned replacement parts available.

The dealer is responsible for replacing the defective part by his own service personnel or through a Denki Onkyo Authorized Service Center.

This Warranty is effective only to the original purchaser and only when the Warranty Registration Card is fully and properly filled out and returned to the factory within 7 days from date of original purchase.



EXPLODED VIEWS AND PARTS LISTS

TABLE OF CONTENTS

EXPLODED VIEW

CABINET EXPLODED VIEW
FLAME WORK EXPLODED VIEW
AMP EXPLODED VIEW (1)
AMP EXPLODED VIEW (2)
MECHANISM EXPLODED VIEW (1)
PARTIAL EXPLODED VIEW (1)
PARTIAL EXPLODED VIEW (2)
MECHANISM EXPLODED VIEW (2)
PARTIAL EXPLODED VIEW
MECHANISM EXPLODED VIEW (3)
PARTIAL EXPLODED VIEW (1)
PARTIAL EXPLODED VIEW (2)

PARTS LISTS

CABINET EXPLODED VIEW
FLAME WORK EXPLODED VIEW
AMP EXPLODED VIEW (1)
AMP EXPLODED VIEW (2)
MECHANISM EXPLODED VIEW (1)
PARTIAL EXPLODED VIEW (1)
PARTIAL EXPLODED VIEW (2)
MECHANISM EXPLODED VIEW (2)
PARTIAL EXPLODED VIEW
MECHANISM EXPLODED VIEW (3)
PARTIAL EXPLODED VIEW (1)
PARTIAL EXPLODED VIEW (2)



CABINET EXPLODED VIEW

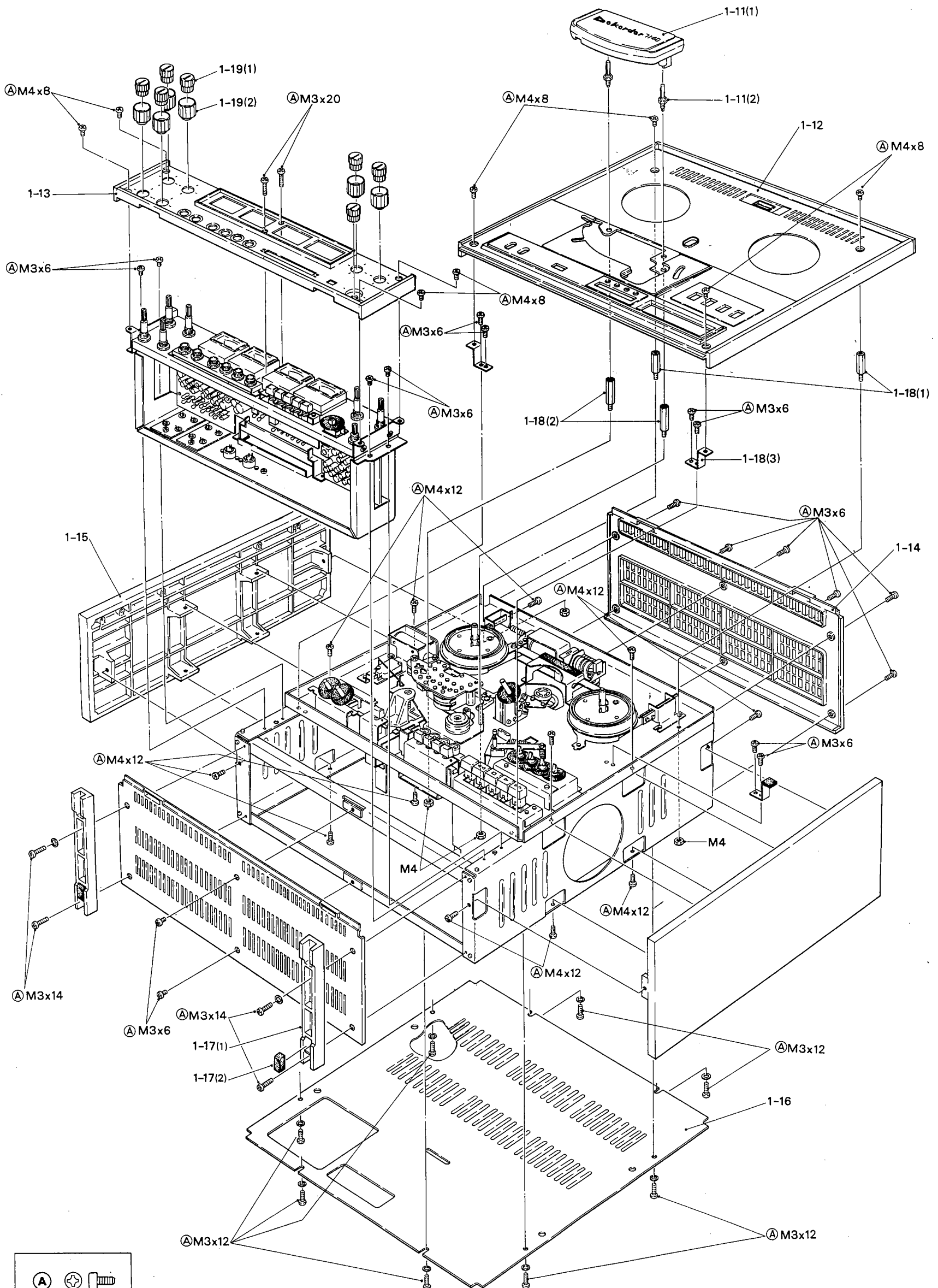



FLAME WORK EXPLODED VIEW

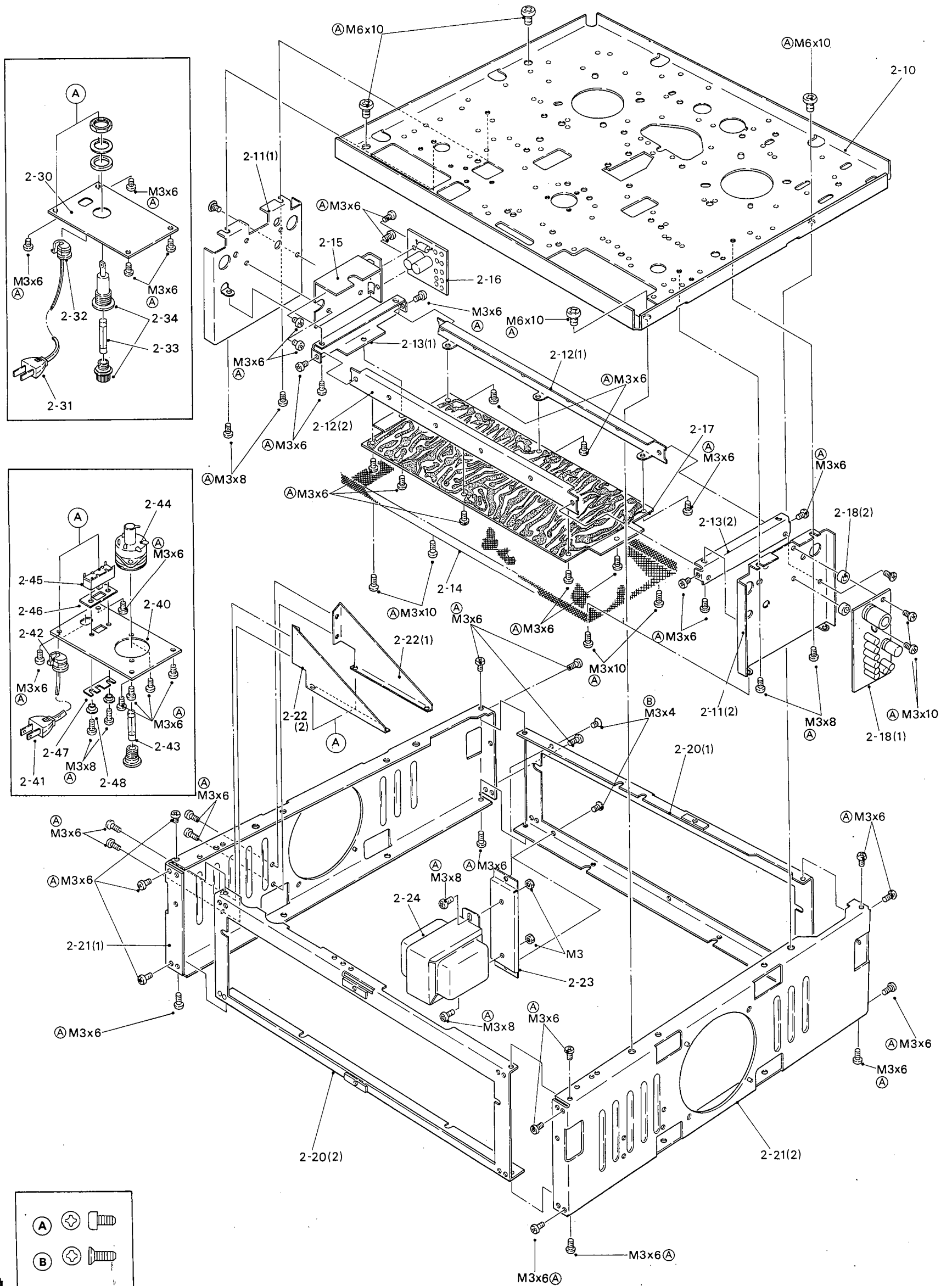

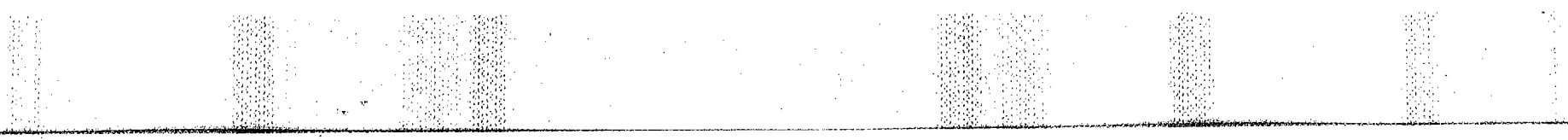

AMP EXPLODED VIEW (1)

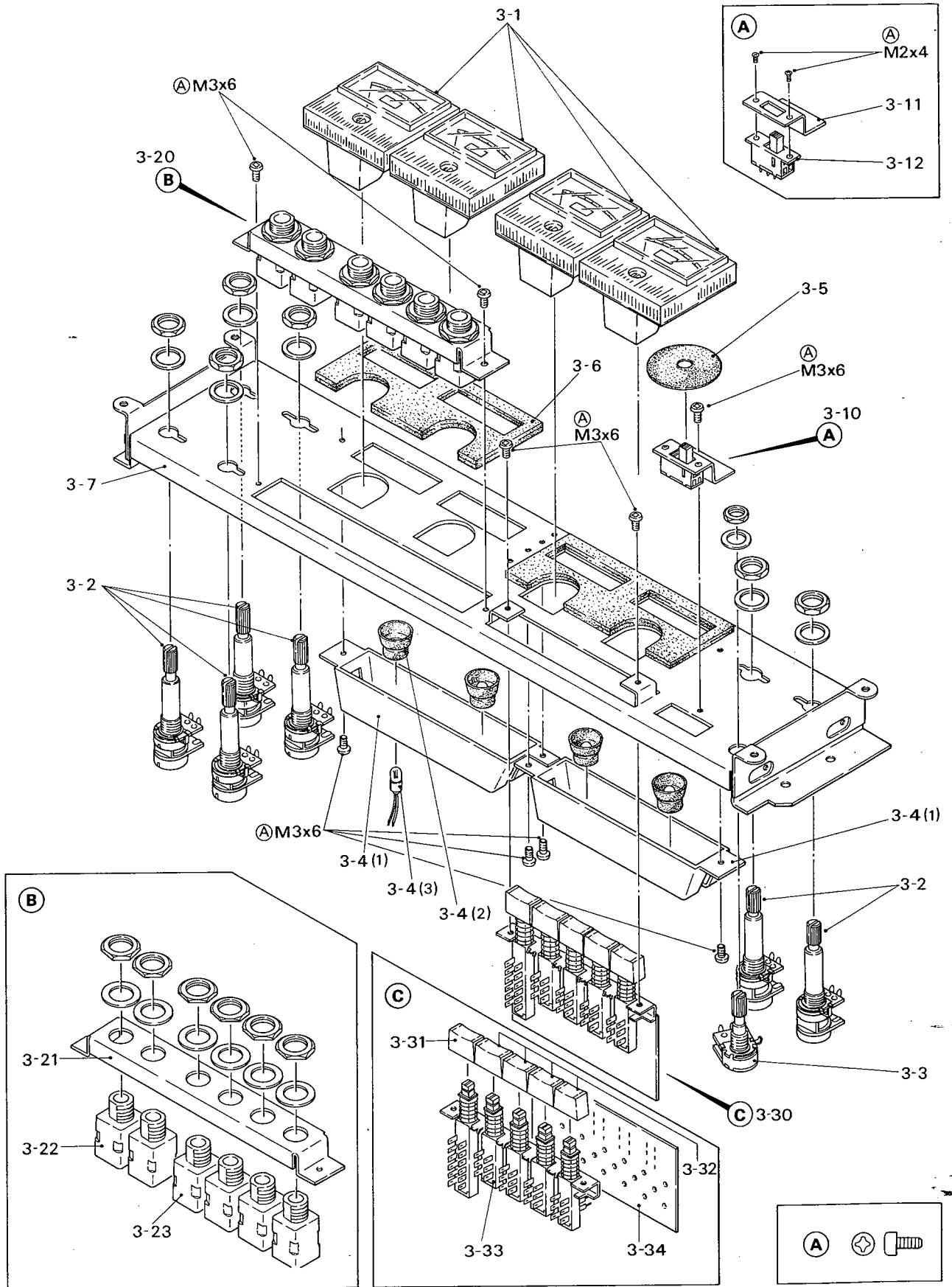



AMP EXPLODED VIEW (2)

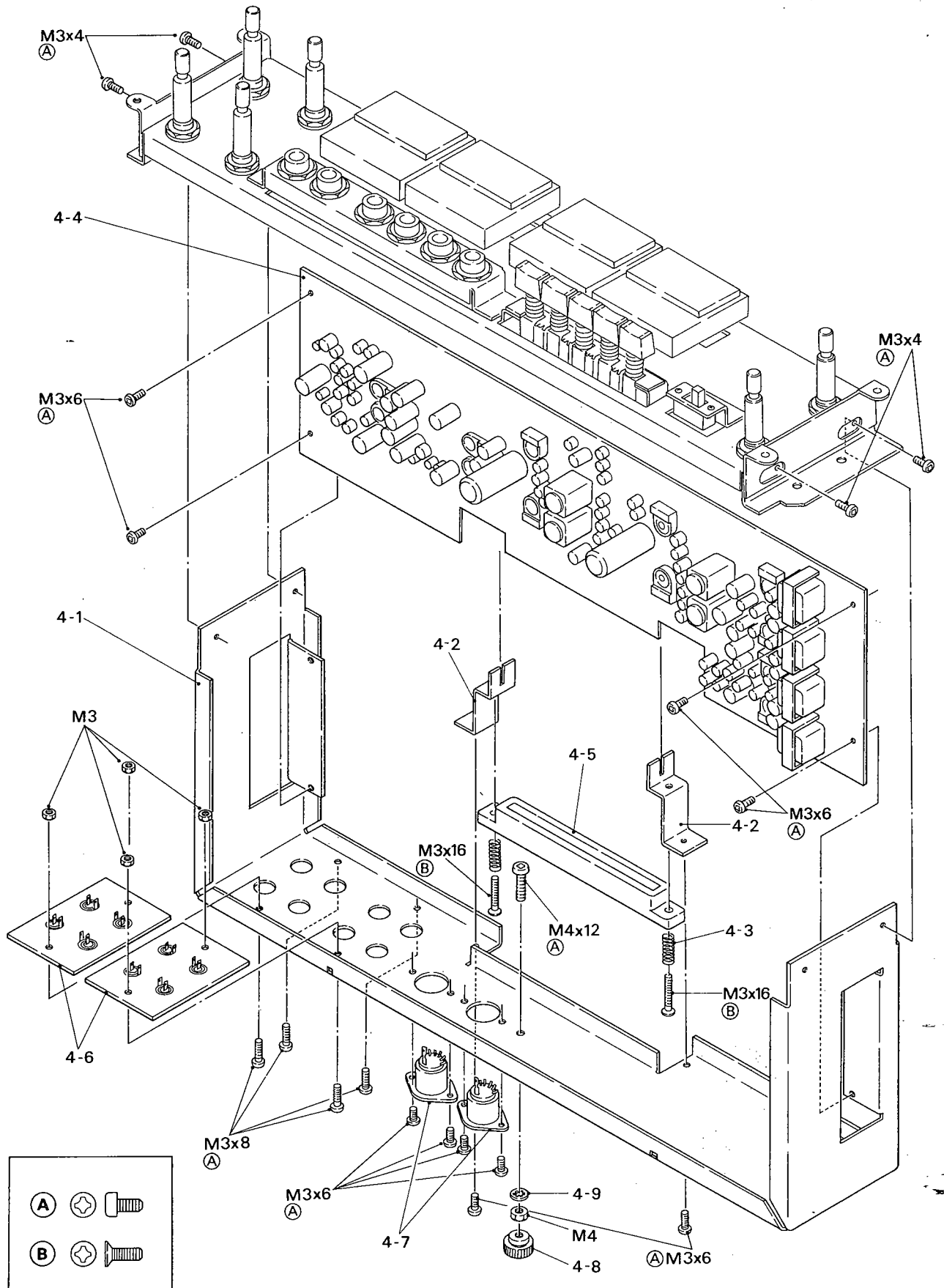



MECHANISM EXPLODED VIEW (1)

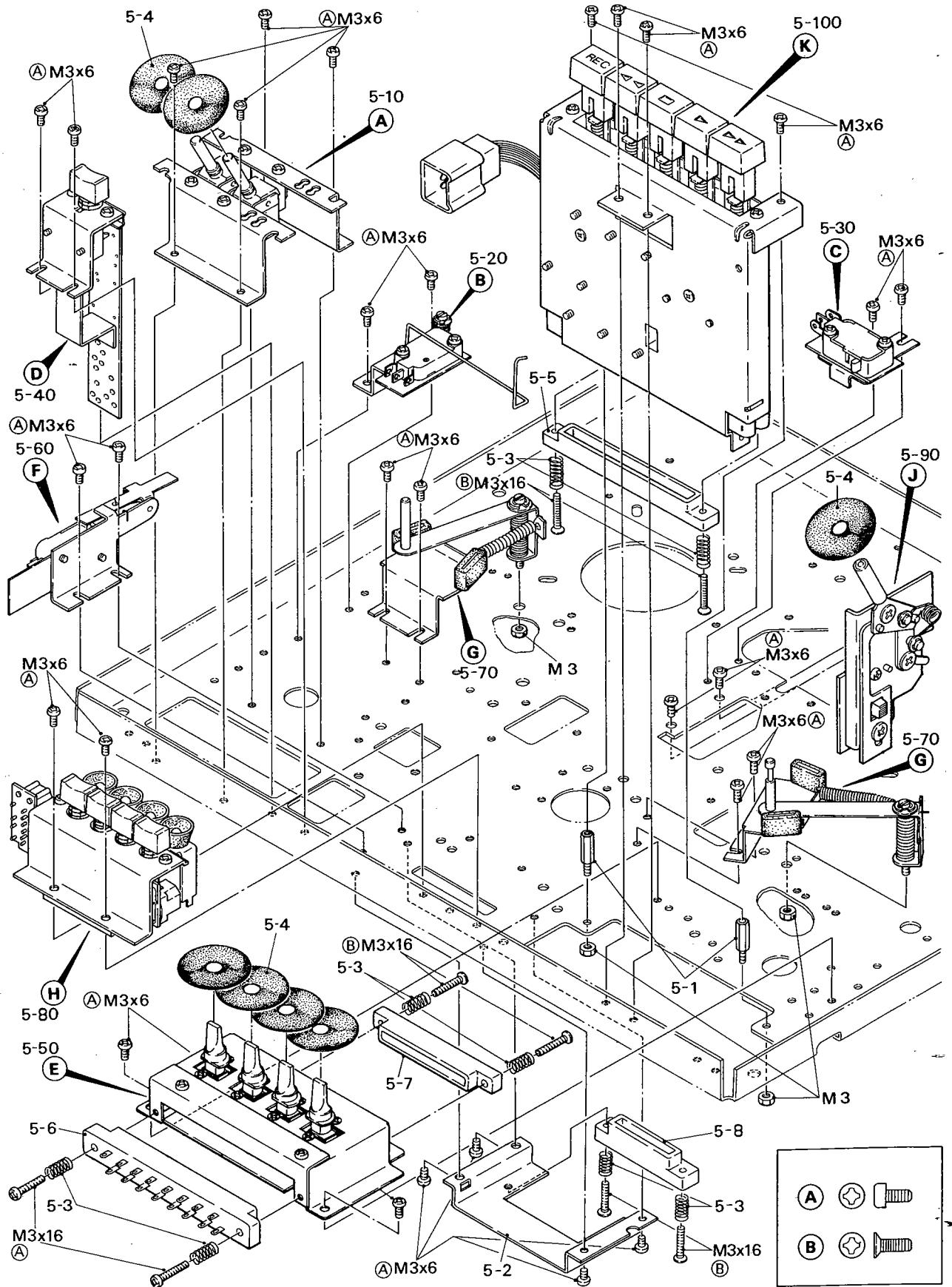



PARTIAL EXPLODED VIEW (1)

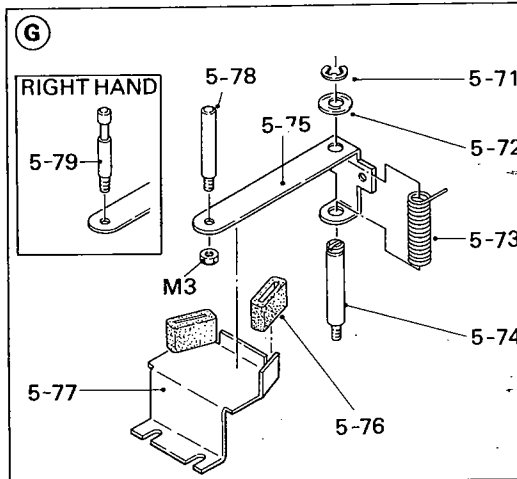
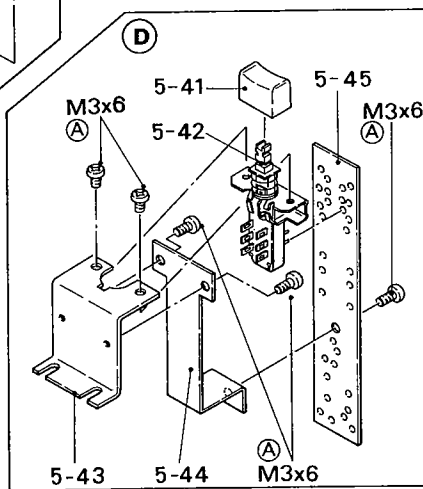
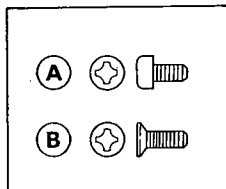
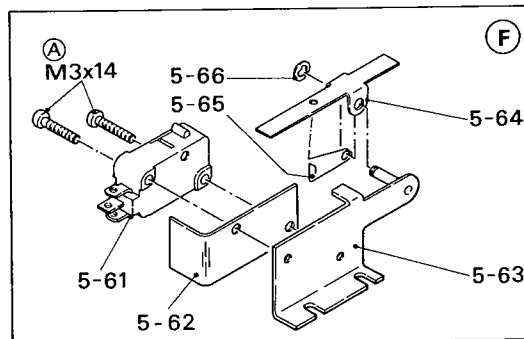
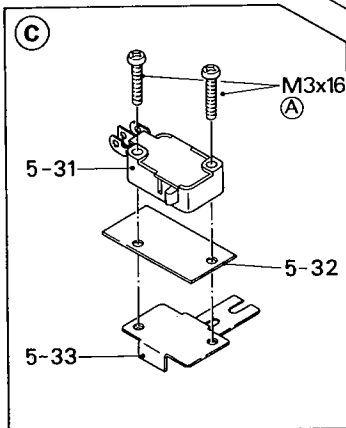
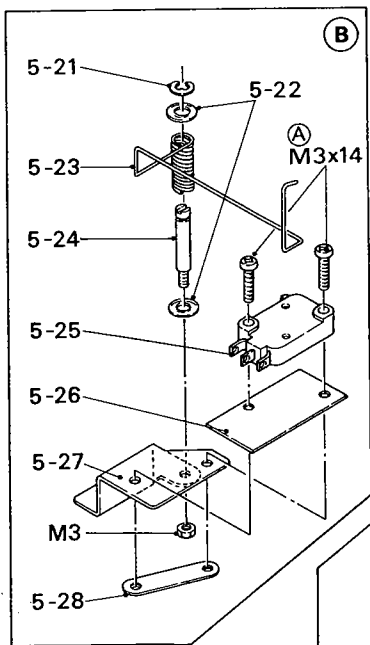
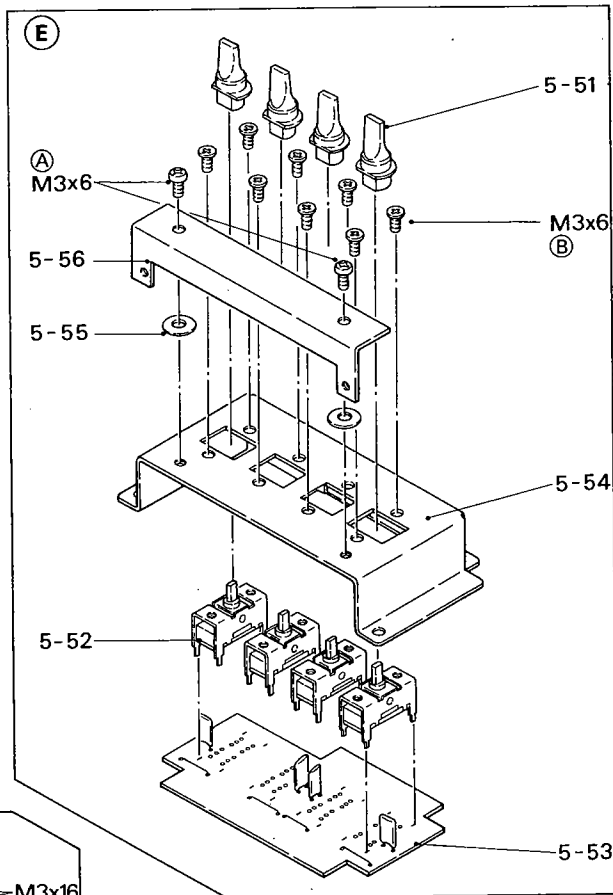
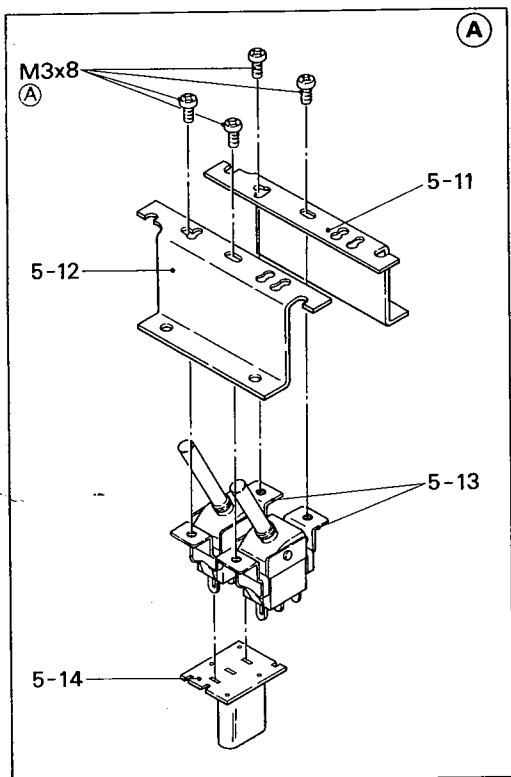



PARTIAL EXPLODED VIEW (2)

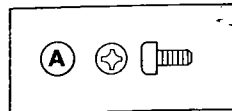
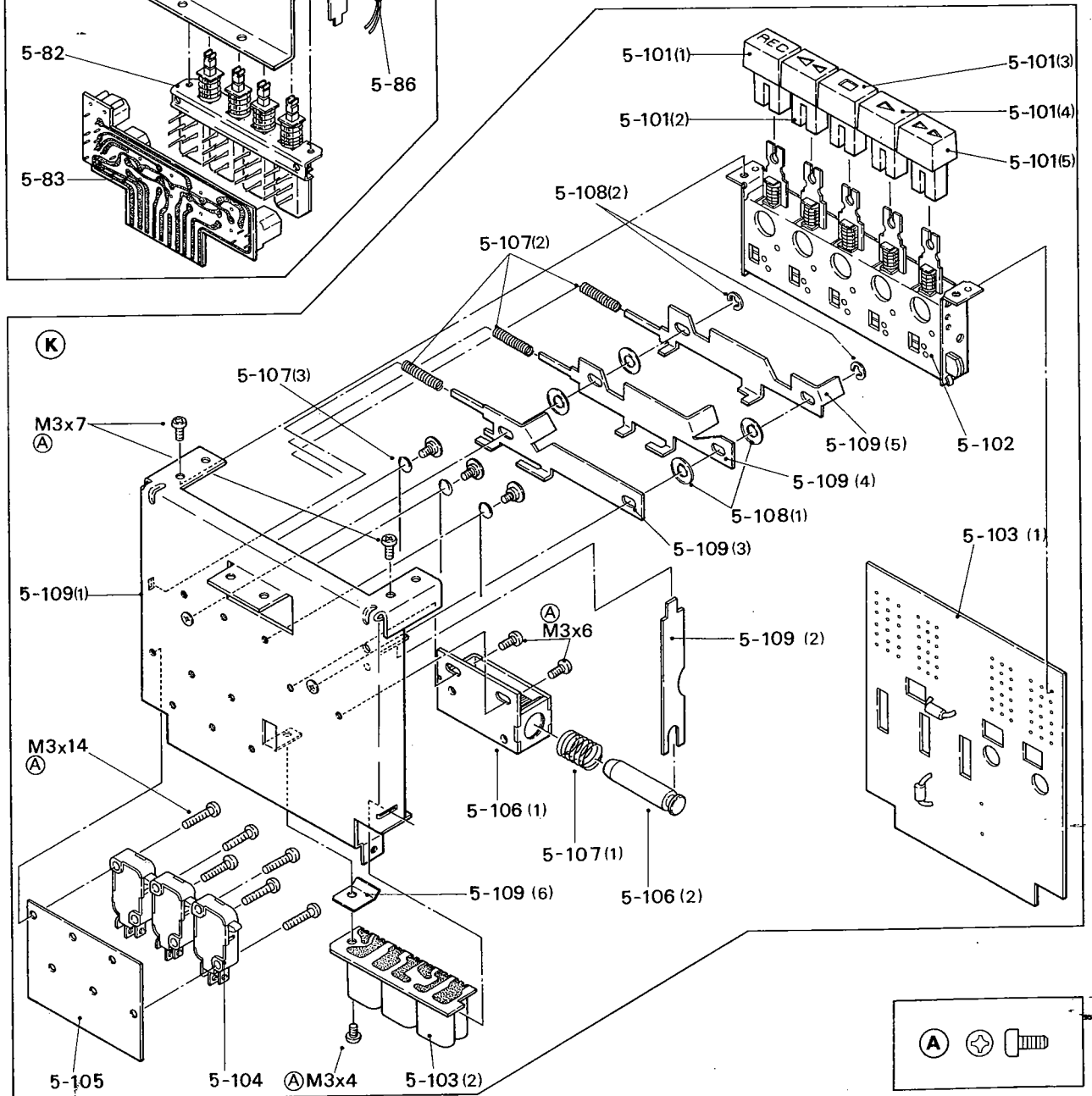
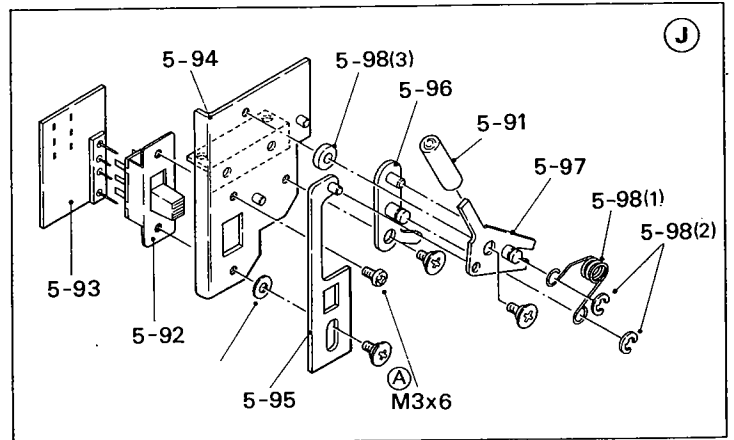
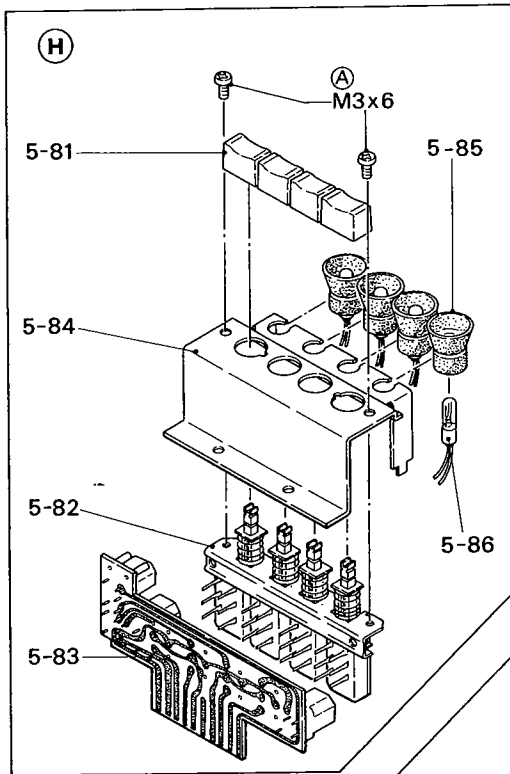



MECHANISM EXPLODED VIEW (2)

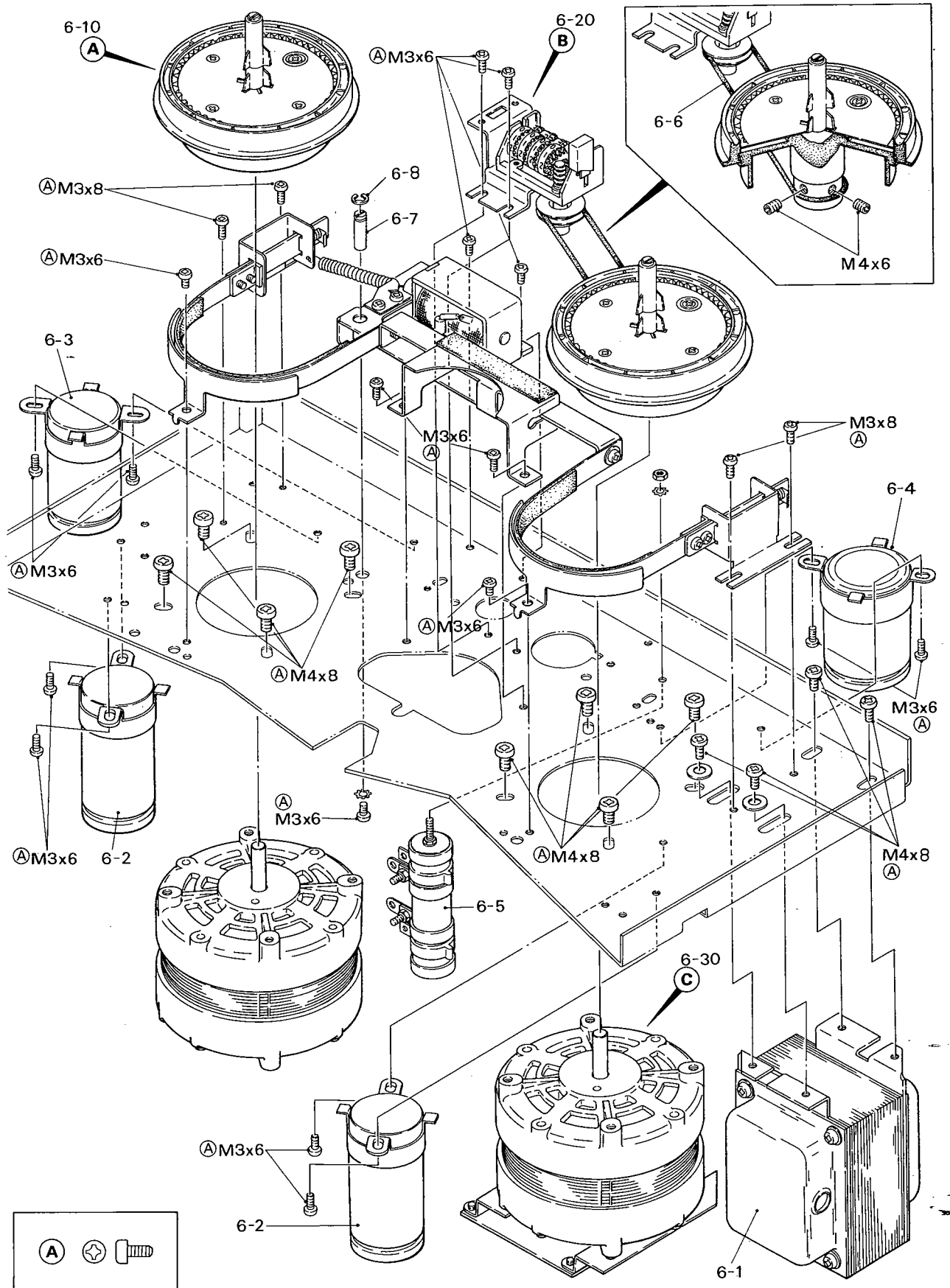



PARTIAL EXPLODED VIEW

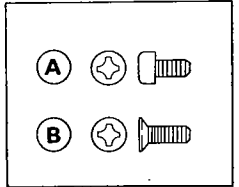
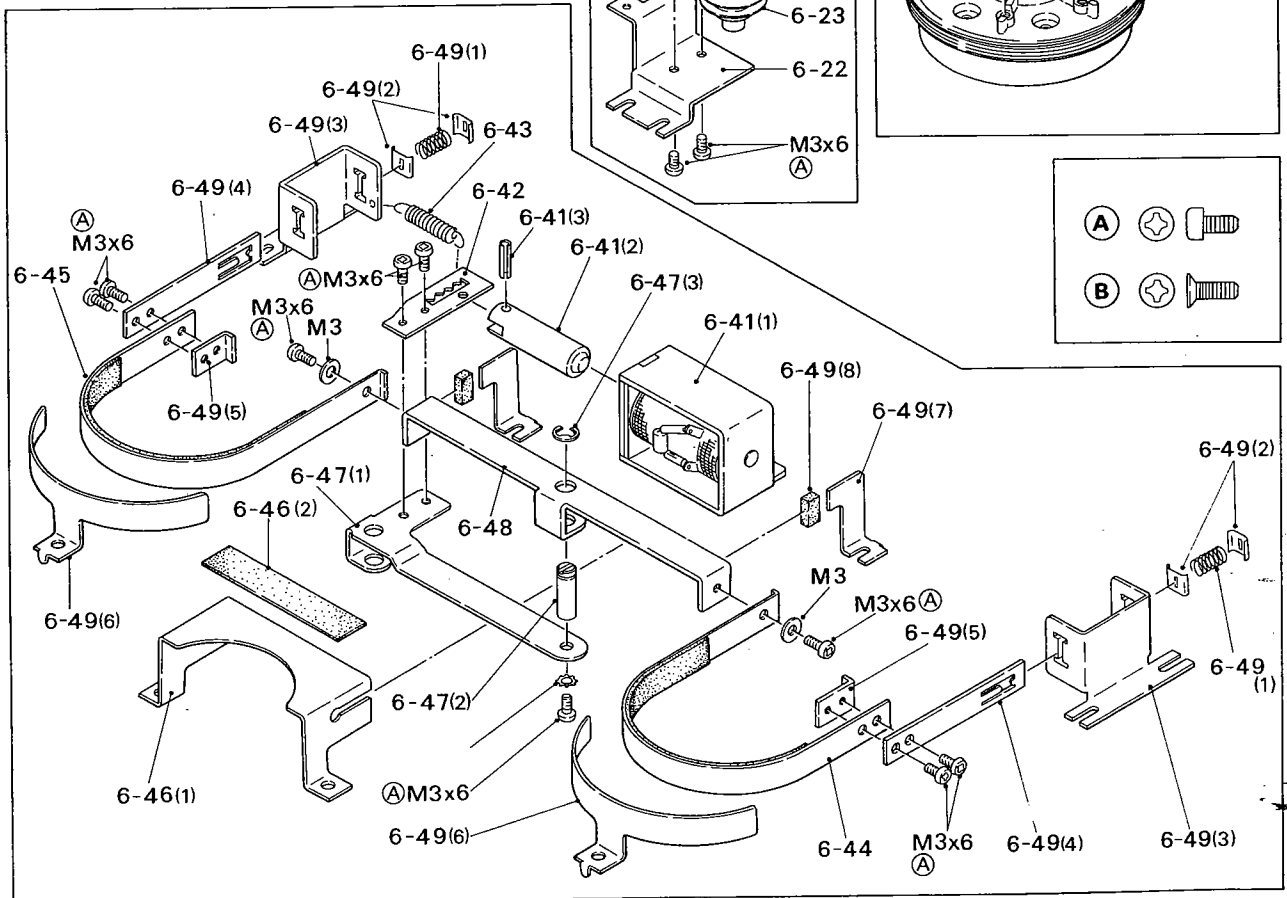
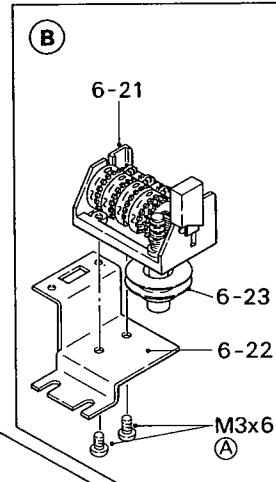
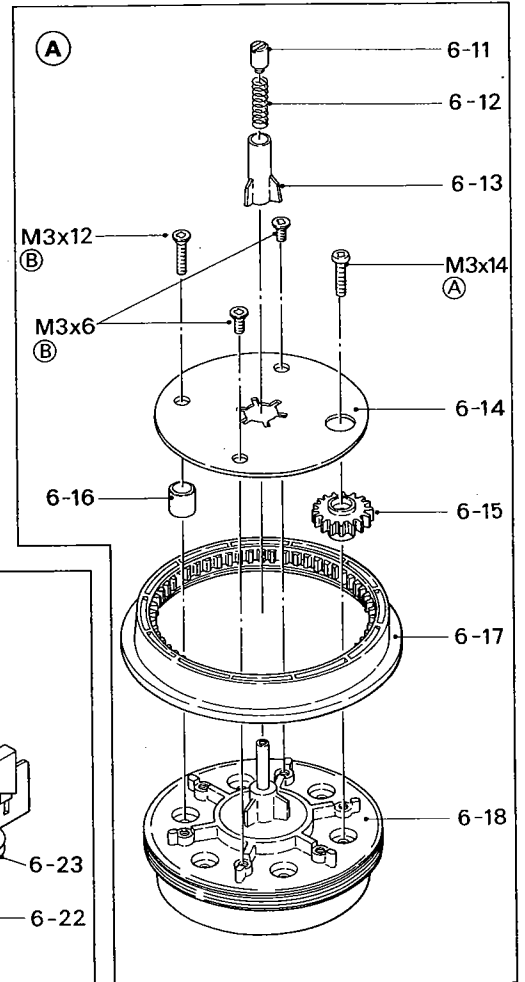
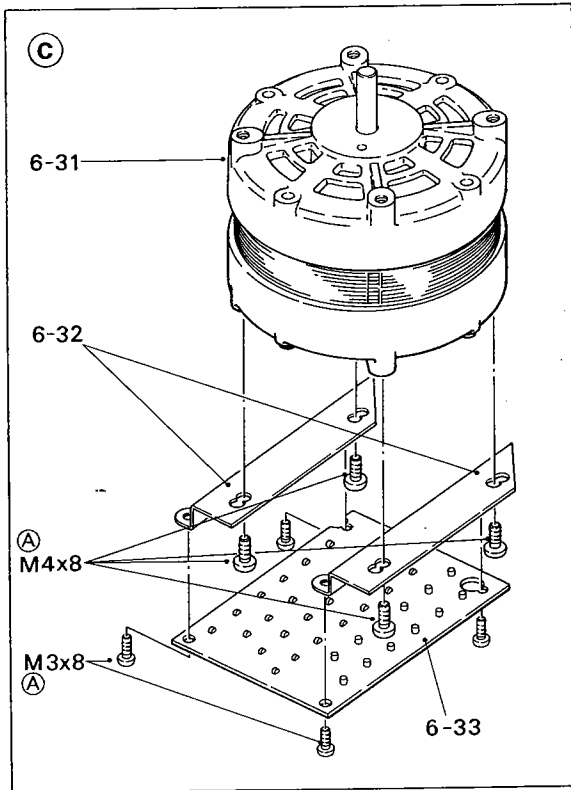



MECHANISM EXPLODED VIEW (3)

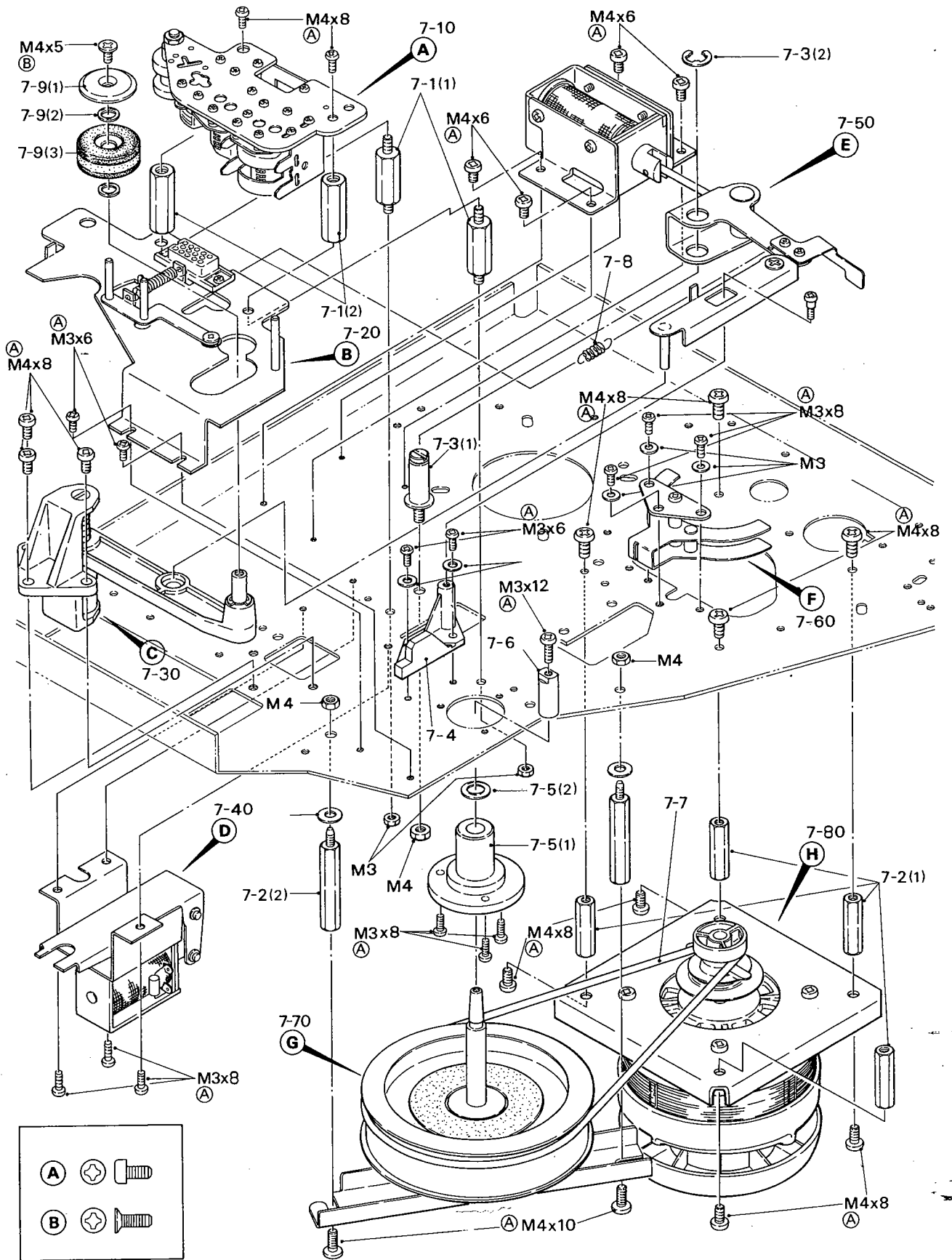



PARTIAL EXPLODED VIEW (1)

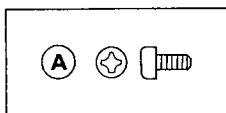
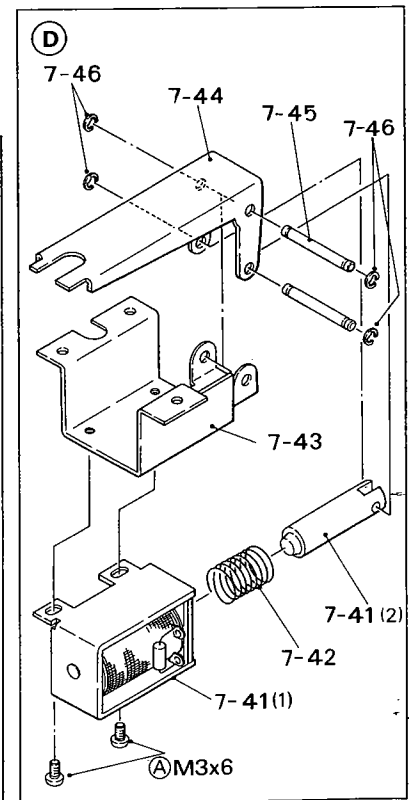
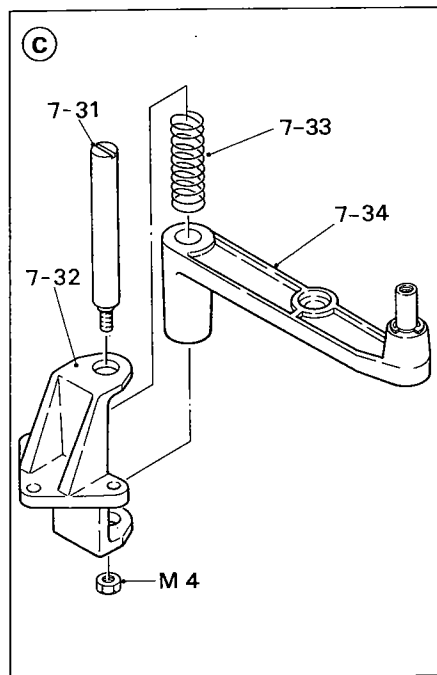
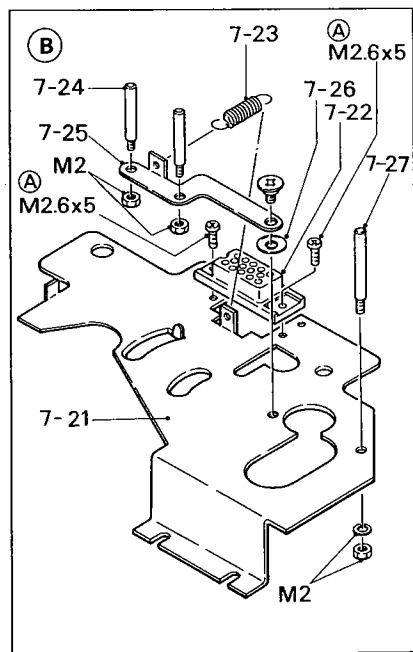
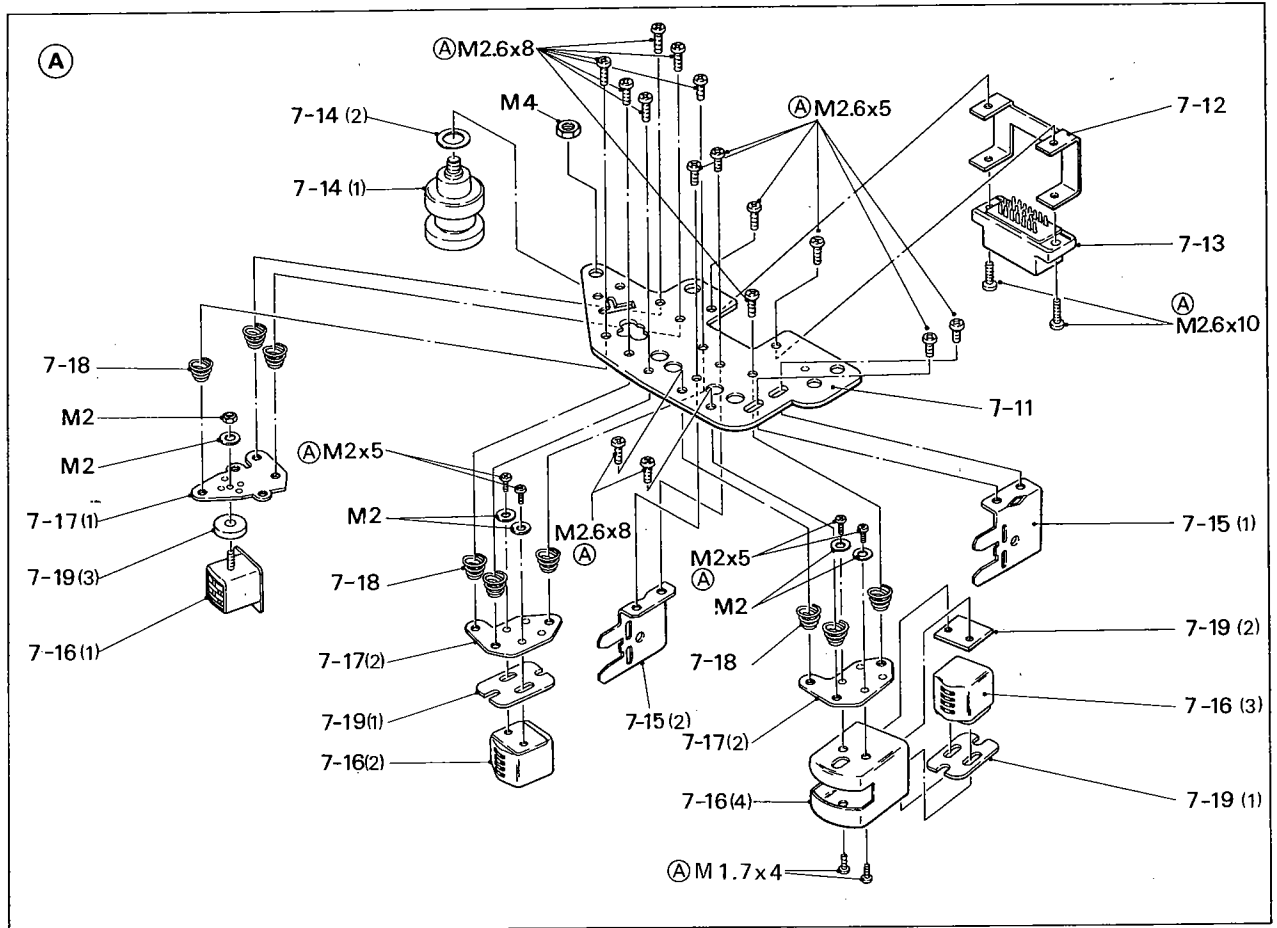



PARTIAL EXPLODED VIEW (2)

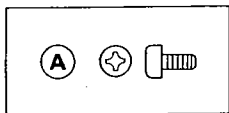
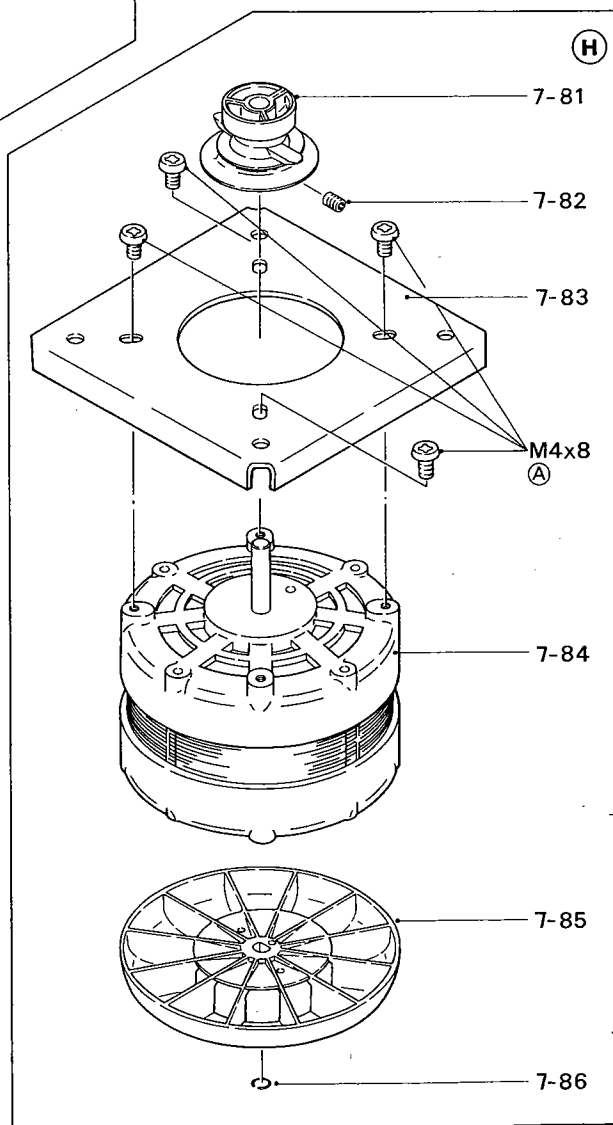
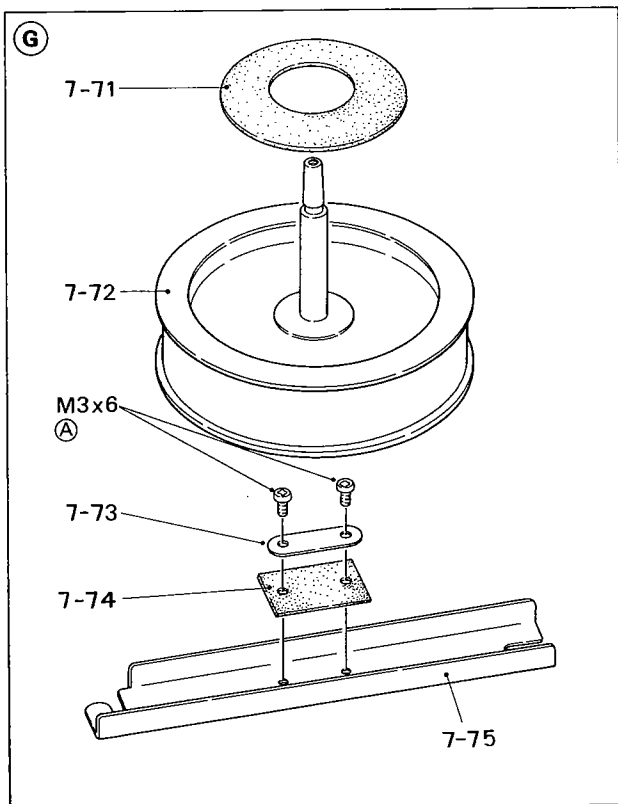
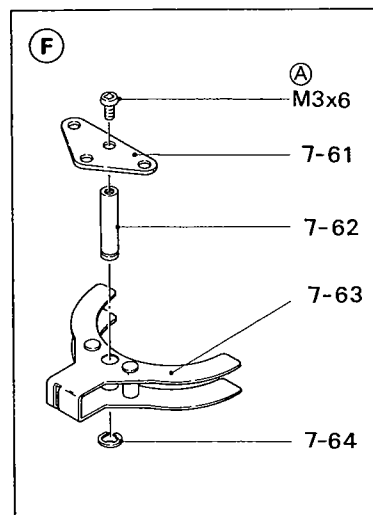
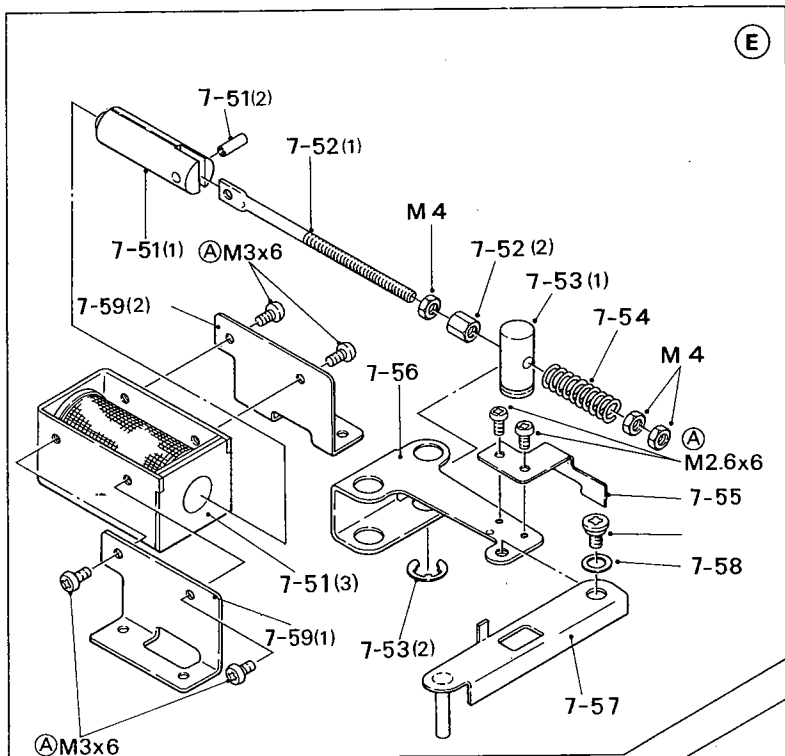



CABINET EXPLODED VIEW

REFERENCE NO.	DESCRIPTION	USER PRICE (\$)
1-11-(1)	HEAD COVER ASS'Y	2.88
1-11-(2)	BANANA TIP	1.40
1-12	FRONT PANEL ASS'Y	13.78
1-13	AMP PANEL ASS'Y	8.66
1-14	UPPER SIDE ASS'Y	9.60
1-15	SIDE BOARD	20.72
1-16	BACK BOARD	5.24
1-17-(1)	LEG	2.56
1-17-(2)	RUBBER LEG	0.20
1-18-(1)	PANEL BOSS	0.64
1-18-(2)	HEAD COVER BOSS	0.64
1-18-(3)	PANEL HOLDER	0.52
1-19-(1)	CONTROL KNOB, INNER	1.20
1-19-(2)	CONTROL KNOB, OUTER	0.36



FLAME WORK EXPLODED VIEW

REFERENCE NO.	DESCRIPTION	USER PRICE (\$)
2-10	MAIN DECK CHASSIS	22.60
2-11-(1)	CONTROL PCB HOLDER (3)	2.00
2-11-(2)	" (3)	2.00
2-12-(1)	" (1)	1.00
2-12-(2)	" (1)	1.00
2-13-(1)	" (2)	0.70
2-13-(2)	" (2)	0.70
2-14	PCB SHIELD BOARD	4.50
2-15	HEAT SINK	1.70
2-16	CONTROL TR PCB ASS'Y	9.50
2-17	CONTROL PCB ASS'Y	76.50
2-18-(1)	MUTING PCB ASS'Y	12.00
2-18-(2)	RING	0.20
2-20-(1)	DECK HOLDER (B)	9.40
2-20-(2)	" (C)	9.60
2-21-(1)	" (A)	7.40
2-21-(2)	" (A)	7.40
2-22-(1)	PWR CHASSIS HOLDER (1)	1.20
2-22-(2)	" (2)	1.20
2-23	AUTO TRANSFORMER HOLDER (ONLY UNIV.)	0.96
2-24	AUTO TRANSFORMER (ONLY UNIV.)	36.00
(U.S.A.) TYPE		
2-30	PWR SOURCE CHASSIS (A)	1.60
2-31	AC CORD	3.60
2-32	CORD STOPPER	0.30
2-33	FUSE 3A	0.80
2-34	FUSE HOLDER	2.50
2-35	(E) RING	0.04
(UNIVERSAL) TYPE		
2-40	PWR SOURCE CHASSIS (B)	1.00
2-41	AC CORD	3.60
2-42	CORD STOPPER	0.30
2-43	FUSE 3A	0.80
2-44	VOLTAGE SELECTER WITH FUSE HOLDER	4.40
2-45	SLIDE SW	1.52
2-46	SLIDE SW INSULATOR	0.17
2-47	SLIDE SW LOCK BOARD	0.12
2-48	DOUBLE WASHER	0.08
2-49	(E) RING	0.04



AMP EXPLODED VIEW (1)

REFERENCE NO.	DESCRIPTION	USER PRICE (\$)
3-1	VU METER	14.80
3-2	VARIABLE RESISTER 50K OHMS (B)	3.80
3-3	"	3.80
3-4(1)	LAMP HOUSE	1.50
3-4(2)	LAMP BUSHING	0.18
3-4(3)	METER LAMP	1.40
3-5	MASK	0.10
3-6	METER CUSHION	0.30
3-7	AMP CHASSIS (A)	6.70
	(A) SLIDE SW ASS'Y	
3-10	SLIDE SW ASS'Y	1.30
3-11	SLIDE SW HOLDER	0.40
3-12	SLIDE SW	0.84
	(B) JACK ASS'Y	
3-20	JACK ASS'Y	7.00
3-21	JACK HOLDER	1.00
3-22	HEAD PHONE JACK	2.16
3-23	MIC JACK	1.64
	(C) MONITOR/MODE SW ASS'Y	
3-30	MONITOR/MODE SW ASS'Y	10.00
3-31	PUSH BUTTON (BLUE)	0.20
3-32	PUSH BUTTON (BLACK)	0.20
3-33	PUSH SW	8.40
3-34	SW PCB	1.16



AMP EXPLODED VIEW (2)

REFERENCE NO.	DESCRIPTION	USER PRICE (\$)
4-1	AMP CHASSIS (B)	0.80
4-2	CONNECTOR HOLDER	0.50
4-3	CONNECTOR SPRING	0.10
4-4	AMP PCB ASS'Y	82.40
4-5	CONNECTOR	5.80
4-6	PIN JACK 4P	2.00
4-7	DIN SOCKET	1.00
4-8	GROUND TERMINAL	0.25
4-9	METAL WASHER	0.04



MECHANISM EXPLODED VIEW (1)

REFERENCE NO.	DESCRIPTION	USER PRICE (\$)	REFERENCE NO.	DESCRIPTION	USER PRICE (\$)
5-1	OP.E. HOLDER BOSS	0.73	5-70	ⓐ TENSION ARM ASS'Y	3.50
5-2	REC CONNECTOR HOLDER	1.00	5-71	TENSION ARM (A, B) ASS'Y	0.04
5-3	CONNECTOR SPRING	0.10	5-72	E RING 4 ϕ	0.08
5-4	MASK	0.04	5-73	NYLON WASHER 5 ϕ	0.26
5-5	CONNECTOR	5.20	5-74	DAMPER SPRING	0.40
5-6	"	5.20	5-75	TENSION SHAFT	1.30
5-7	"	4.00	5-76	TENSION ARM	0.12
5-8	"	6.00	5-77	TENSION DAMPER	0.56
5-9	"		5-78	TENSION ARM UNDER COVER	0.52
			5-79	GUIDE POLE (A)	1.00
				GUIDE POLE (B)	
5-10	Ⓐ LEVER SW ASS'Y	4.50	5-80	ⓑ REC SW ASS'Y	17.00
5-11	LEVER SW ASS'Y	0.50	5-81	REC SW ASS'Y	0.20
5-12	LEVER SW HOLDER (A)	0.50	5-82	PUSH BUTTON	6.40
5-13	" (B)	3.60	5-83	PUSH SW	4.98
5-14	LEVER SW PCB ASS'Y	0.76	5-84	REC SW PCB ASS'Y	1.00
			5-85	REC SW HOLDER	0.18
5-20	ⓑ AUTO SHUT OFF SW ASS'Y	7.50	5-86	LAMP BUSHING	1.40
5-21	AUTO SHUT OFF SW ASS'Y	0.04		REC LAMP	
5-22	(E) RING 3 ϕ	0.08		Ⓐ SPEED CHANGE LEVER ASS'Y	5.00
5-23	NYLON WASHER 4 ϕ	1.13	5-90	SPEED CHANGE LEVER ASS'Y	0.84
5-24	AUTO SHUT ARM	0.73	5-91	SPEED CHANGE KNOB	1.00
5-25	AUTO SHUT SHAFT	2.56	5-92	SLIDE SW	0.52
5-26	MICRO SW	0.60	5-93	EQ CHANGE SW PCB ASS'Y	2.20
5-27	MICRO SW INSULATOR	3.34	5-94	SPEED CHANGE LEVER HOLDER	0.48
5-28	AUTO SHUT SW STOPPER	0.24	5-95	SPEED CHANGE LEVER (2)	0.50
			5-96	" (1)	0.40
5-30	Ⓒ PRESSURE SW ASS'Y	6.00	5-97	" (1)	0.30
5-31	PRESSURE SW ASS'Y	1.90	5-98-(1)	SPEED CHANGE LEVER SPRING	0.04
5-32	MICRO SW	0.06	5-98-(2)	(E) RING 3 ϕ	
5-33	MICRO SW INSULATOR	4.16	5-98-(3)	WASHER FOR MOVING SHIFTER	0.38
5-40	Ⓓ TAPE SELECT SW ASS'Y	2.50	5-100	ⓐ OPE BUTTON SW ASS'Y	50.00
5-41	TAPE SELECT SW ASS'Y	0.18	5-101-(1)	OPE BUTTON SW ASS'Y	0.54
5-42	PUSH BUTTON	1.80	5-101-(2)	REC BUTTON ASS'Y	0.58
5-43	PUSH SW	0.38	5-101-(3)	REW BUTTON ASS'Y	0.58
5-44	TAPE SELECT SW HOLDER	0.42	5-101-(4)	STOP BUTTON ASS'Y	0.58
5-45	TAPE SELECT SW PCB ASS'Y	0.60	5-101-(5)	PLAY BUTTON ASS'Y	0.58
			5-102	F.F. BUTTON ASS'Y	15.60
5-50	Ⓔ MULTI SYNC SW ASS'Y	11.00	5-103-(1)	5 GANG PUSH SW	2.98
5-51	MULTI SYNC SW ASS'Y	0.26	5-103-(2)	5 GANG PCB ASS'Y	4.00
5-52	LEVER SW KNOB	2.20	5-104	SPARK KILLER PCB ASS'Y	1.90
5-53	LEVER SW	1.88	5-105	MICRO SW	0.06
5-54	MULTI SYNC PCB ASS'Y	1.90	5-106-(1)	MICRO SW INSULATOR	7.60
5-55	MULTI SYNC SW HOLDER	0.20	5-106-(2)	SOLENOID	7.60
5-56	FIBER WASHER	0.75	5-107-(1)	SOLENOID PLUNGER	0.14
			5-107-(2)	SOLENOID SPRING	0.14
			5-107-(3)	SLIDING BOARD SPRING	0.13
			5-108-(1)	ACTUATER SPRING	0.08
			5-108-(2)	NYLON WASHER 5 ϕ	0.04
			5-109-(1)	(E) RING 3 ϕ	5.70
			5-109-(2)	OPE BUTTON SW HOLDER	0.50
			5-109-(3)	SOLENOID LEVER	1.30
			5-109-(4)	SLIDING BOARD (1)	0.90
			5-109-(5)	" (2)	1.20
				" (3)	



MECHANISM EXPLODED VIEW (2)

REFERENCE NO.	DESCRIPTION	USER PRICE (\$)
6-1	PWR TRANSFORMER	54.00
6-2	CAPACITOR 4 + 0.5 μ F 250V	16.00
6-3	" 1.5 + 0.5 μ F 250V	5.60
6-4	" 2200 μ F 50V	6.40
6-5	RESISTOR 1200 OHMS 20W	4.20
6-6	COUNTER BELT	1.00
6-7	BRAKE SHAFT ARM	0.40
6-8	(E)RING 5 ϕ	0.04
(A) REEL TABLE ASS'Y		
6-10	REEL TABLE ASS'Y	10.00
6-11	SHAFT CAP	0.72
6-12	REEL CRAMP SPRING	0.16
6-13	REEL CRAMP	0.36
6-14	DRESSING PLATE	1.20
6-15	PINION GEAR	0.68
6-16	SPACER	0.40
6-17	RING	2.44
6-18	REEL TABLE	9.16
(B) COUNTER ASS'Y		
6-20	COUNTER ASS'Y	9.00
6-21	COUNTER	8.20
6-22	COUNTER HOLDER	0.36
6-23	COUNTER PULLEY	0.36
(C) REEL MOTOR ASS'Y		
6-30	REEL MOTOR ASS'Y	70.00
6-31	REEL MOTOR	69.20
6-32	PCB HOLDER	0.52
6-33	CONNECTING PCB	2.52
(D) BRAKE ASS'Y		
6-40	BRAKE ASS'Y	12.00
6-41-(1)	SOLENOID	8.80
6-41-(2)	PLUNGER	8.80
6-41-(3)	SPRING PIN	0.12
6-42	SOLENOID CONNECTER	0.72
6-43	BRAKE SPRING	0.28
6-44	BRAKE BAND	0.24
6-45	BRAKE SHOE	0.20
6-46-(1)	BRAKE CONNECTER GUIDE	0.72
6-46-(2)	FRONT PANEL DAMPER	0.08
6-47-(1)	BRAKE ARM	0.92
6-47-(2)	BRAKE ARM SHAFT	0.40
6-47-(3)	(E)RING 5 ϕ	0.04
6-48	BRAKE CONNECTER	1.04
6-49-(1)	SPRING TO LIMIT BRAKE	0.12
6-49-(2)	BRAKE SPRING METAL WASHER	0.20
6-49-(3)	BRAKE HOLDER	0.56
6-49-(4)	BRAKE CONTROL BOARD	0.36
6-49-(5)	BRAKE BAND STOPPER	0.32
6-49-(6)	BRAKE BAND GUIDE	0.64
6-49-(7)	BRAKE CONNECTING BOARD STOPPER	0.28
6-49-(8)	DAMPER	0.20



MECHANISM EXPLODED VIEW (3)

REFERENCE NO.	DESCRIPTION	USER PRICE (\$)	REFERENCE NO.	DESCRIPTION	USER PRICE (\$)
7-1-(1)	HEAD STAND BOSS (A)	0.84			
7-1-(2)	" (B)	0.80	7-40		
7-2-(1)	MOTOR CHASSIS BOSS	0.72	7-41-(1)		
7-2-(2)	FLYWHEEL SUPPORT	0.68	7-41-(2)		
7-3-(1)	MOVING ARM SHAFT FOR PINCH ROLLER	0.84	7-42		
7-3-(2)	(E)RING	0.04	7-43		
7-4	ARM GUIDE FOR PINCH ROLLER (2)	0.96	7-44		
7-5-(1)	CAPSTAN METAL	7.20	7-45		
7-5-(2)	OIL CUT WASHER	0.20	7-46		
7-6	CAPSTAN SLEEVE	5.20			
7-7	CAPSTAN BELT	9.40			
7-8	SPRING FOR MOVING SHIFTER	0.20	7-50		
7-9-(1)	PINCH ROLLER DRESSING PLATE	1.20	7-51-(1)		
7-9-(2)	NYLON WASHER 6.2φ	0.08	7-51-(2)		
7-9-(3)	PINCH ROLLER	3.80	7-51-(3)		
	Ⓐ HEAD MOUNT ASS'Y		7-52-(1)		
7-10	HEAD MOUNT ASS'Y	160.00	7-52-(2)		
7-11	HEAD PLATE	1.40	7-53-(1)		
7-12	HOLDER OF CONNECTOR	0.52	7-53-(2)		
7-13	CONNECTOR (20P) BOSS	6.60	7-54		
7-14-(1)	OUTER TAPE GUIDE	11.60	7-55		
7-14-(2)	WASHER 4φ	0.20	7-56		
7-15-(1)	INNER TAPE GUIDE	0.56	7-57		
7-15-(2)	"	0.56	7-58		
7-16-(1)	ERASE HEAD	64.00	7-59-(1)		
7-16-(2)	RECORD HEAD	88.00	7-59-(2)		
7-16-(3)	PLAY BACK HEAD	92.00			
7-16-(4)	HEAD SHIELD	4.20	7-60		
7-17-(1)	HEAD HOLDER (E)	1.00	7-61		
7-17-(2)	HEAD HOLDER	0.68	7-62		
7-18	HEAD SPRING	0.12	7-63		
7-19-(1)	HEAD SPACER (C)	0.24	7-64		
7-19-(2)	HEAD SHIELD FIXING PLATE	0.20			
7-19-(3)	HEAD SPACER RING	0.48			
	Ⓑ BANDAGE PLATER ASS'Y				
7-20	BANDAGE PLATE ASS'Y	7.00	7-70		
7-21	BANDAGE PLATE	3.84	7-71		
7-22	CONNECTER (20P), FEMALE	6.40	7-72		
7-23	SHIFTER SPRING	0.12	7-73		
7-24	SHIFT POLE	0.68	7-74		
7-25	TAPE SHIFTER BOARD	0.80	7-25		
7-26	NYLON WASHER 5φ	0.20	7-80		
7-27	GUIDE POLE	0.52	7-81		
	Ⓒ PINCH ARM ASS'Y		7-82		
7-30	PINCH ARM ASS'Y	3.60	7-83		
7-31	PINCH ARM SHAFT	1.92	7-84		
7-32	PINCH ARM HOLDER	2.00	7-85		
7-33	PINCH ARM SPRING	0.20	7-86		
7-34	PINCH ARM ASS'Y	2.00			
	Ⓓ PUSH UP SOLENOID ASS'Y				
	PUSH UP SOLENOID ASS'Y	22.38			
	SOLENOID	9.60			
	PLUNGER	9.60			
	SPRING	0.16			
	HOLDER	0.92			
	PUSH UP ARM	0.76			
	PINCH ARM SHAFT	0.36			
	(E)RING 2φ	0.04			
	Ⓔ PINCH ROLLER DRIVING ARM ASS'Y				
	PINCH ROLLER DRIVING ARM ASS'Y	17.70			
	PLUNGER	13.00			
	SPRING PIN	0.08			
	SOLENOID	13.60			
	PINCH ROLLER CONNECTING ROD	1.00			
	ADJUSTING NUT	0.40			
	PINCH SOLENOID SHAFT	1.20			
	(E)RING 5φ	0.04			
	SPRING (PINCH ROLLER)	0.20			
	ACTUATOR	1.08			
	DRIVING ARM (PINCH ROLLER)	1.00			
	CONNECTING BOARD	1.28			
	NYLON WASHER 6φ	0.20			
	SOLENOID HOLDER	1.00			
	SOLENOID HOLDER	1.00			
	Ⓕ FORK METAL FITTINGS ASS'Y				
	FORK METAL FITTINGS ASS'Y	6.00			
	SHAFT HOLDER	0.32			
	SHAFT	0.32			
	FORK	0.48			
	(E)RING 3φ	5.40			
	Ⓖ FLYWHEEL ASS'Y				
	FLYWHEEL ASS'Y	25.00			
	OIL STOPPER	0.20			
	FLYWHEEL	24.00			
	STOPPER	0.12			
	OIL FERT	0.20			
	FLYWHEEL HOLDER	1.08			
	Ⓗ CAPSTAN MOTOR ASS'Y				
	CAPSTAN MOTOR ASS'Y	80.00			
	MOTOR POOLIE	5.20			
	HEXAGON SCREW	0.28			
	MOTOR CHASSIS	1.20			
	CAPSTAN MOTOR	75.20			
	MOTOR FAN	2.00			
	ROCK SPRING	0.40			



11



Dokorder

Information for your Service Department
Prepared and Distributed by Dokorder Inc., Service Dept.

SERVICE MANUAL
SM-0130-00
MODEL 7140

SCHEMATIC DIAGRAMS

MODEL 7140

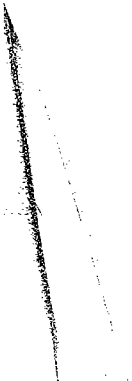

DECK SCHEMATIC DIAGRAM

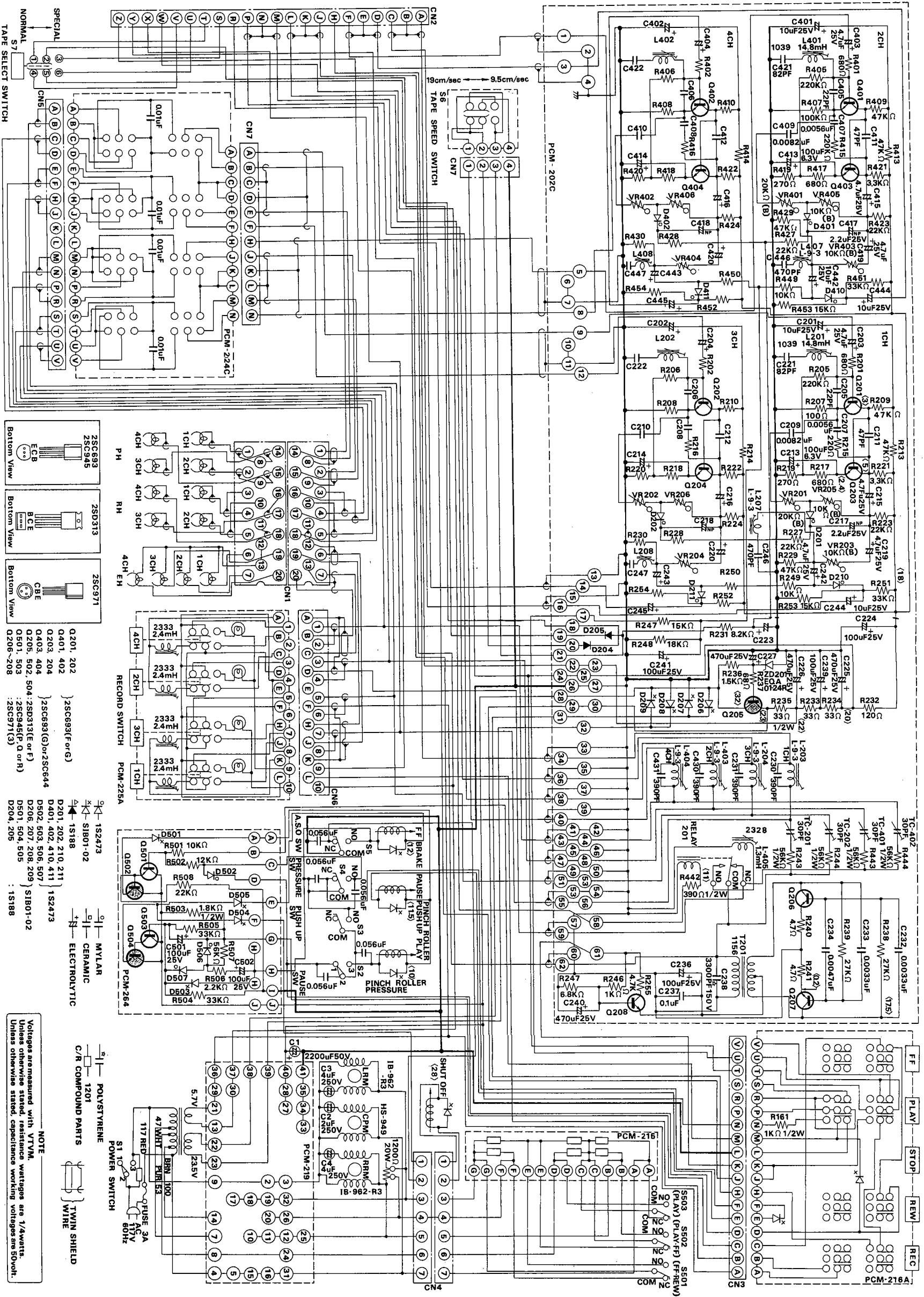

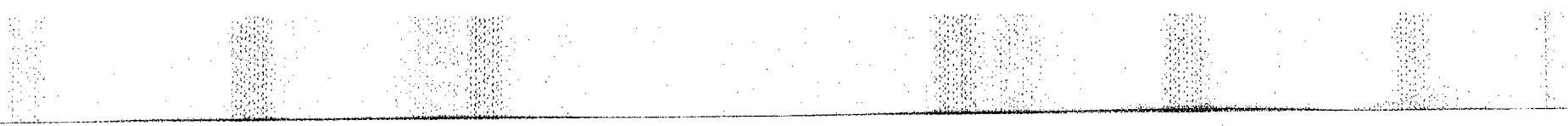

AMP SCHEMATIC DIAGRAM

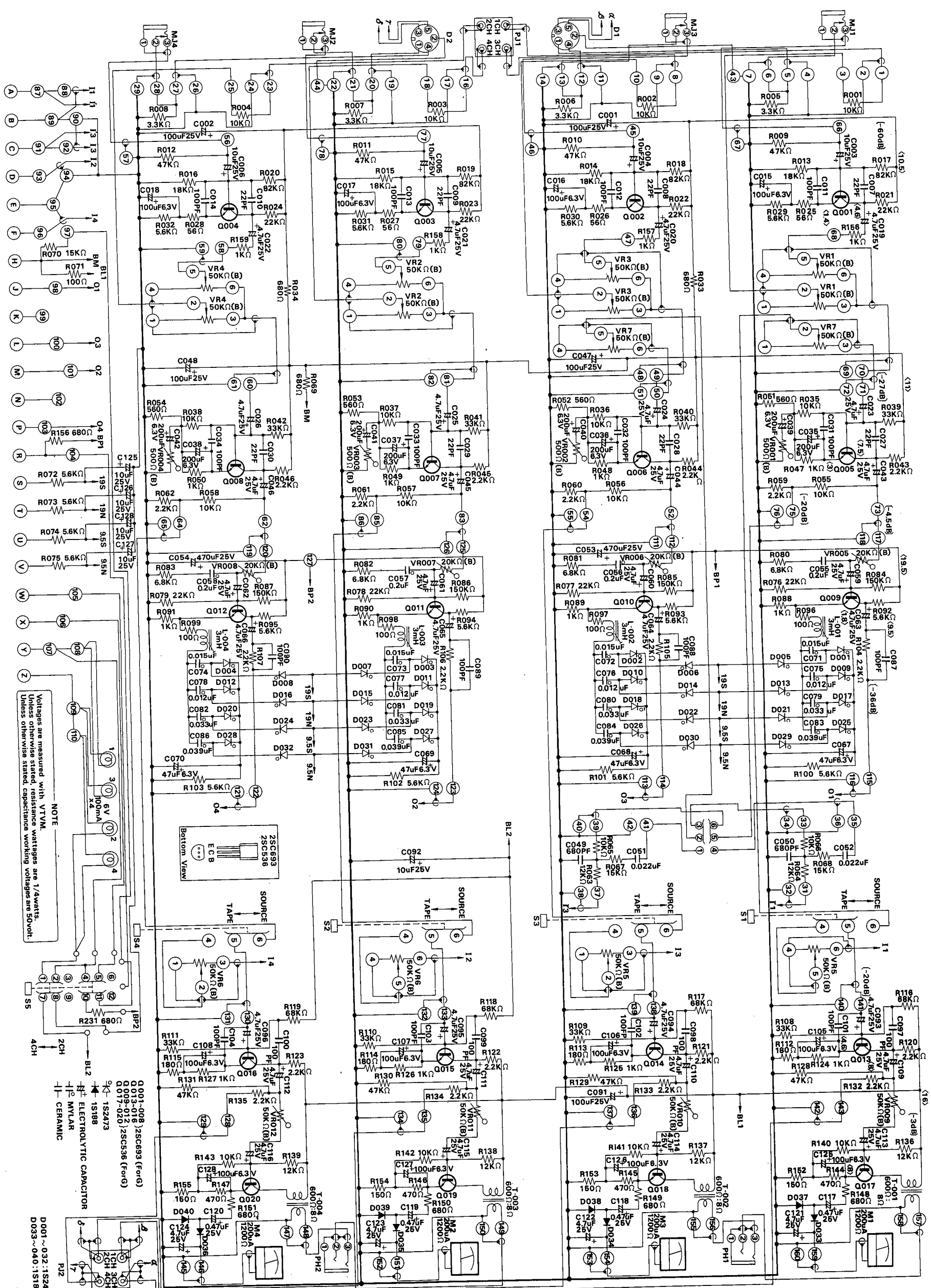

NOTE
 Voltages are measured with VTVM.
 Unless otherwise stated, resistance working voltages are 1/4watts.
 Unless otherwise stated, capacitance working voltages are 50volt.

- Q001-Q008 2SC693 (For G)
- Q009-Q012 2SC536 (For G)
- Q017-Q020 2SC536 (For G)
- Q021-Q023 1S2473
- Q024-Q026 1S188
- Q027-Q029 ELECTROLYTIC CAPACITOR
- Q030 CERAMIC
- Q031 MYLAR

D001-Q032: 1S2473
 D033-Q040: 1S188



SERVICE TIPS

Information for your Service Department
Prepared and Distributed by Dokorder Inc., Service Dept.

TABLE OF CONTENTS

1. CLEANING

- 1-1. CLEANING THE HEADS
- 1-2. CLEANING OTHER SURFACES THAT COME INTO CONTACT WITH THE TAPE
- 1-3. WHAT PARTS TO CLEAN ON EACH DOKORDER MODEL

2. DEMAGNETIZING

- 2-1. DEMAGNETIZING THE HEADS
- 2-2. WHAT PARTS TO DEMAGNETIZE

3. LUBRICATION

- 3-1. MOTORS
- 3-2. CAPSTAN
- 3-3. PINCH ROLLER

4. AVOID THESE PLACES TO PREVENT DAMAGE

5. HOW TO CHECK BROKEN TRANSISTORS AND DIODES

6. COLOR-CODING CHART



CLEANING

The magnetic heads are the most vital parts of a tape recorder. The slightest amount of dirt or dust on a head could deteriorate its frequency response, or reduce the effective signal level for recording or playback. In some cases, dirt or dust could even make a head totally ineffective, preventing its recording or playback function, creating 'jumps' in the recorded or reproduced sound, or failing to erase all of the previously recorded sound.

For this reason, it is recommendable to clean the heads periodically and keep them clean at all times. (Ideally, it should be made a practice to clean the heads before every recording session.) Other surfaces that come into contact with the tape are also important and should be cleaned periodically, too. These include the tension arms, tape guides, pinch roller, capstan sleeve, auto shut-off switch, guide poles, etc. Dirt, dust, oil and the like on any of these parts is likely to prevent smooth travel of the tape, make it slip, increase the wow, or make the sound unsteady.

1-1. CLEANING THE HEADS

- 1) Remove the head cover (6) gently and expose the heads.
- 2) Attach a wad of cotton or a piece of gauze to the tip of a small wooden stick, soak it with a commercially available head cleaning liquid, then wipe the head surfaces (Fig. 1-1) gently with it. Be careful not to nick or scratch the heads when wiping.
- 3) Wait until the head surfaces become completely dry to thread the tape again.

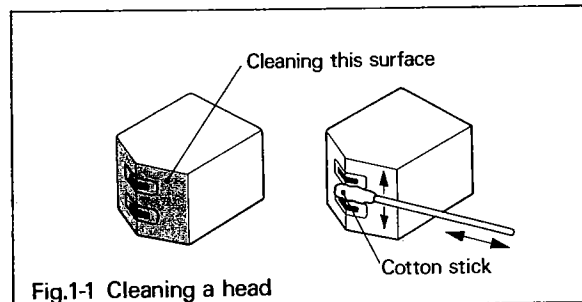

Fig.1-1 Cleaning a head

1-2. CLEANING OTHER SURFACES THAT COME INTO CONTACT WITH THE TAPE

- 1) Wet a piece of gauze or soft lintless cloth with the cleaning liquid, and, holding it between your finger tips, wipe the tension arms, tape guides, auto shut-off switch and other externally exposed parts.
- 2) Wipe the capstan and pinch roller while they are revolving. To do this, push the PLAY BUTTON (46) and start the tape recorder. Since there is no tape, however, the auto shut-off switch will be activated. Now, push the auto shut-off switch gently, and the capstan sleeve and pinch roller will begin to revolve. Take a cotton swab stick soaked with the cleaning liquid, and apply it to the capstan sleeve as illustrated in Fig. 1-2 (A), and then to the pinch roller as illustrated in Fig. 1-2 (B). The position shown by dotted lines as (C) is dangerous and must be avoided.

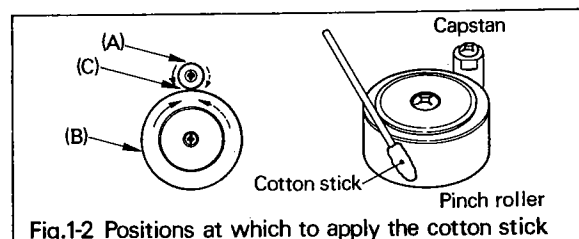

Fig.1-2 Positions at which to apply the cotton stick



CAUTION

1. When wiping the capstan sleeve and pinch roller, be careful to prevent the cotton swab stick from being caught.
2. For cleaning, always use a commercially available head cleaning liquid or carbon tetrachloride.

—1-3. WHAT PARTS TO CLEAN ON EACH DOKORDER MODEL—

The parts that come into contact with the tape and therefore should be cleaned are illustrated by arrows in Fig. 1-3 through Fig. 1-5 for each different Dokorder tape recorder model.

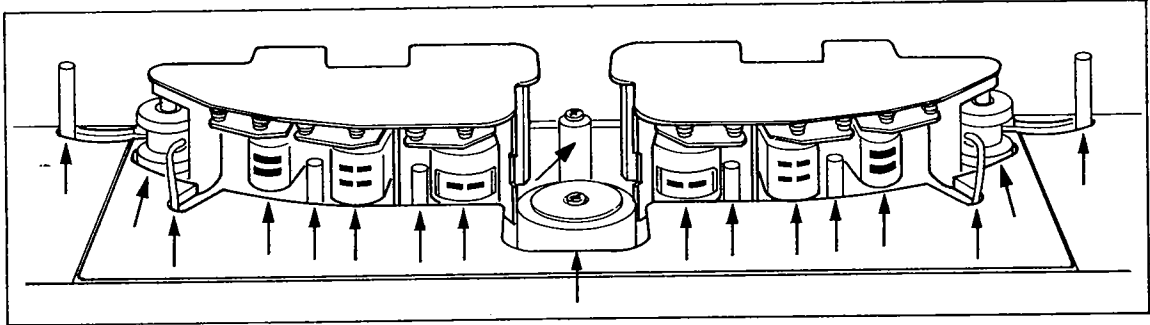

Fig. 1-3 The parts to clean on Dokorder models 9200 & 7500

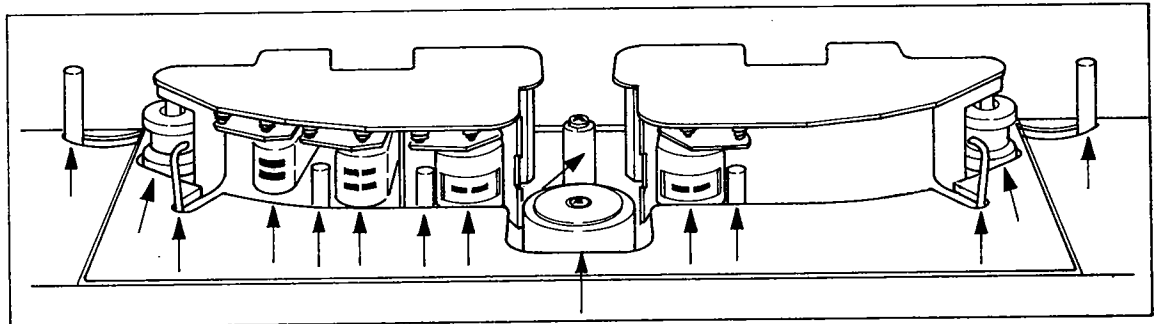

Fig. 1-4 The parts to clean on Dokorder model 7200

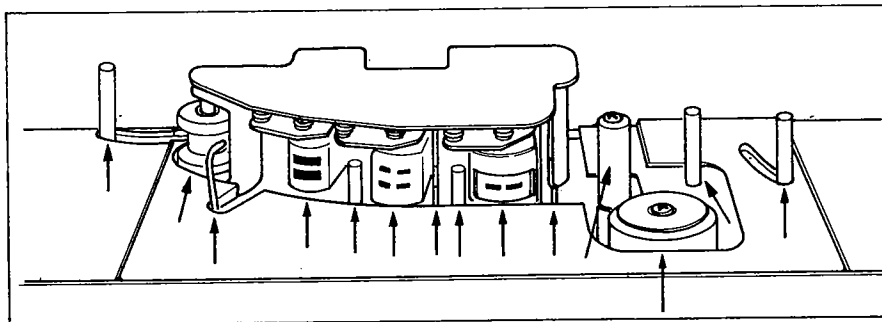

Fig. 1-5 The parts to clean on Dokorder models 7100 & 7140



1

DEMAGNETIZING

A magnetic head may be magnetized because of an electrical accident in the tape recorder's amplifier, or a wrong operation of the tape recorder, or when a magnetized object touches it. This will result in deterioration of the head's frequency response and an increase in its noise level. The most common tendency of a recording head is to become magnetized when an unbalanced pulse signal enters it. Such a pulse signal is usually generated by the tape recorder's signal circuit or power supply circuit, and can be avoided if the following precautions are observed:

- 1) Do not touch the transistors, resistors and capacitors in the tape recorder's recording circuit with the leads of a tester, etc., while a recording is in progress.
- 2) Do not check the conduction of the coil in a magnetic head with a tester and the like. In other words, do not apply a DC current to the coil. If a head is magnetized, be sure to demagnetize it with a demagnetizer (head eraser).

Also, a head is gradually magnetized with use, and this will usually increase the noise content in a recording. It is therefore advisable to instruct your customer to demagnetize the heads from time to time (once every 50 hours of use, at least), using a demagnetizer (head eraser). Follow the procedures given below to demagnetize the heads and other parts.

2-1. DEMAGNETIZING THE HEADS

- 1) Shut off the power switch (8) of the tape recorder.
- 2) Turn on the power switch of the demagnetizer.
- 3) Bring the tips of the demagnetizer close to the head surface (but don't let it touch it), and move the tips over the head surface up and down three or four times (see Fig. 2-1), then pull the demagnetizer away from the head slowly. Repeat this process several times until the head is sufficiently demagnetized.

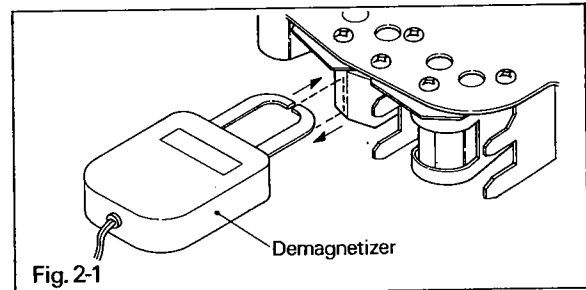

Demagnetizing a head

- 4) When the head is sufficiently demagnetized, pull the demagnetizer at least 12 inches away from the head and shut off its power switch.

2-2. WHAT PARTS TO DEMAGNETIZE

- 1) Erase head, record head and play head.
- 2) Capstan shaft, tape guides, tension arms and auto shut-off switch.



LUBRICATION

Generally, the bearings of rotary parts require lubrication. On Dokorder tape decks, the bearings of the motors, capstan and pinch roller are the parts that require lubrication. Follow the procedures given below to lubricate them.

3-1. MOTORS

The two reel drive motors and one capstan drive motor require lubrication after a year's use. As illustrated in Fig. 3-1, however, each Dokorder motor has its oil-less metal shaft surrounded with an extra large oil storage space and can therefore run for more than 2,000 hours without lubrication. This means there's no need to lubricate the motors in a Dokorder tape deck for approximately a year if it is used up to six hours a day. To lubricate the motors after such a period, apply a few drops of oil into the oil holes of each motor (see Fig. 3-2).

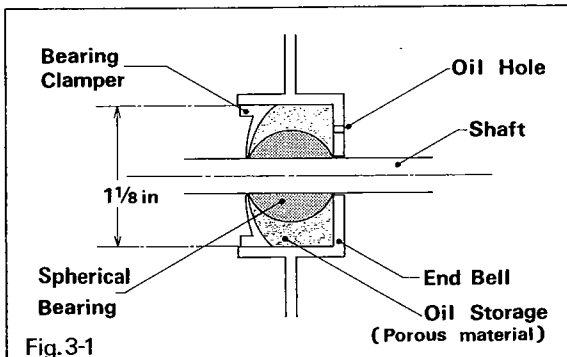

Cross section of a Dokorder motor bearing

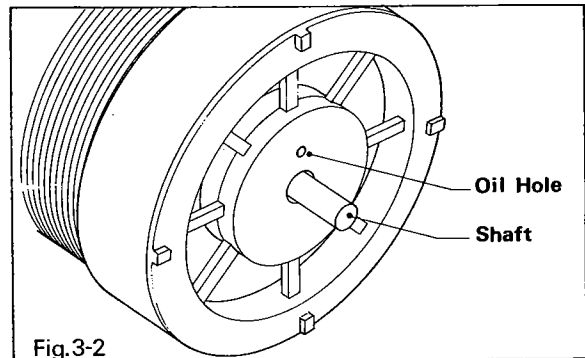

Location of an oil hole on a Dokorder motor

3-2. CAPSTAN

The capstan bearing, which is the most important part in the tape travel system of a tape recorder, is manufactured of a special porous oil-less metal (special aluminum alloy) as illustrated in Fig. 1-3, and can run for over 1,000 hours without lubrication. This means there's no need to lubricate it for approximately six months if it is used up to six hours a day. After such a period is over, apply two drops of oil as illustrated in Fig. 3-3.

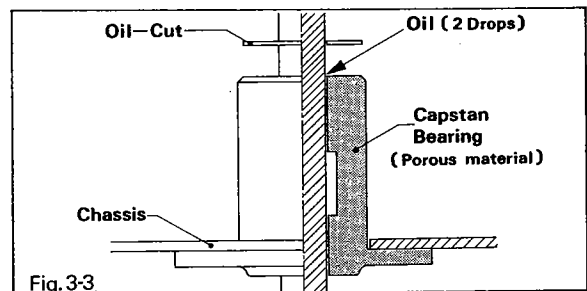

Cross section of a capstan bearing



—3-3. PINCH ROLLER—

The pinch roller bearing, another very important part, is manufactured of a porous oil-less metal (special copper alloy) as indicated in Fig. 1-4, and requires no lubrication for up to six months or so. To lubricate it, apply one drop of oil as shown in Fig. 3-4.

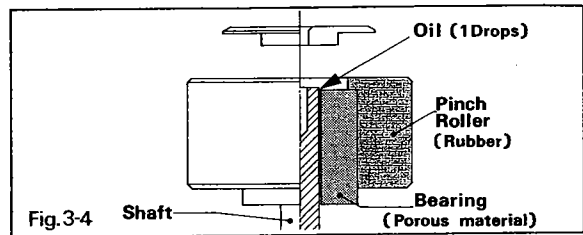

Cross section of a pinch roller bearing

—CAUTION—

- 1) For lubrication, be sure to use high-grade spindle oil or machine oil.
- 2) If the rubber parts of the capstan or pinch roller are stained with oil during the lubricating procedure, be sure to wipe them carefully with the head cleaning liquid or carbon tetrachloride.
- 3) Do not lubricate the rotary parts other than those discussed above. Also, if an excessive amount of oil is applied, it may flow out as the rotary parts are operated and may stain the rubber parts, drive belts, reel brake bands, etc., increasing the wow and causing other undesirable effects.



AVOID THESE PLACES TO PREVENT DAMAGE

If you visit a customer for servicing or repairing and see a Dokorder tape deck being used in one of the places described below, try to suggest that he change the place to prevent damage to the machine.

—Wrong position—

The Dokorder Model 7000 series tape decks are designed as vertical type tape recorders, and should be stood on their ends. If they are laid down on their backs, effective ventilation is prevented and their internal temperature rises to deteriorate the performance.

—High-temperature place—

Under the direct sunshine in summer, near a window where the sunshine directly hits a tape recorder, near a heater in winter, on top of an amplifier or receiver, or any other place where the temperature is likely to be very high should be avoided not only because it deteriorates the tonal quality but because it shortens the service life of a tape recorder. In fact, any place where the ambient temperature is 40°C (104°F) or more should be avoided. The ideal ambient temperature is from 15°C to 30°C (59°F to 86°F).

—Low-temperature places—

Wherever water freezes in winter, the lubricating oil in a Dokorder tape deck tends to freeze, too, hindering smooth revolution of the rotary parts. If possible, avoid places where the ambient temperature is -10°C (14°F) or less.

—High-humidity places—

Avoid a kitchen or any other place where humidity is likely to be high. Ideally, the humidity should be less than 60%. If a tape recorder must be installed where humidity is relatively high, it is important to provide good ventilation.

—Dusty places or places where a tape recorder is subjected to constant vibration—

If a tape recorder is operated in a dusty place, not only do its heads tend to wear faster but its rotary mechanism is more likely to break down. If installed in a place where there is a great deal of vibration, some of the screws may become loose or some joints may be distorted, eventually leading to breakdowns.

—Places where the line voltage fluctuates considerably—

If a tape recorder is installed in a place where the line voltage fluctuates considerably, its performance may become unsteady or eventually deteriorate to the point of a breakdown. In such a place, recommend the use of a voltage regulator. Ideally, the line voltage should not fluctuate by more than ±5% from the rated voltage.

—Other undesirable places—

Avoid other undesirable places where ventilation is likely to be poor, such as inside a cupboard, inside a desk drawer or locker. If a tape recorder must be used in such a place, it is recommended to install a ventilation fan. Then, always keep the back of the tape recorder away from the wall, leaving at least 10cm between them to enable ventilation through the opening on the back of the tape recorder.



HOW TO CHECK BROKEN TRANSISTORS AND DIODES

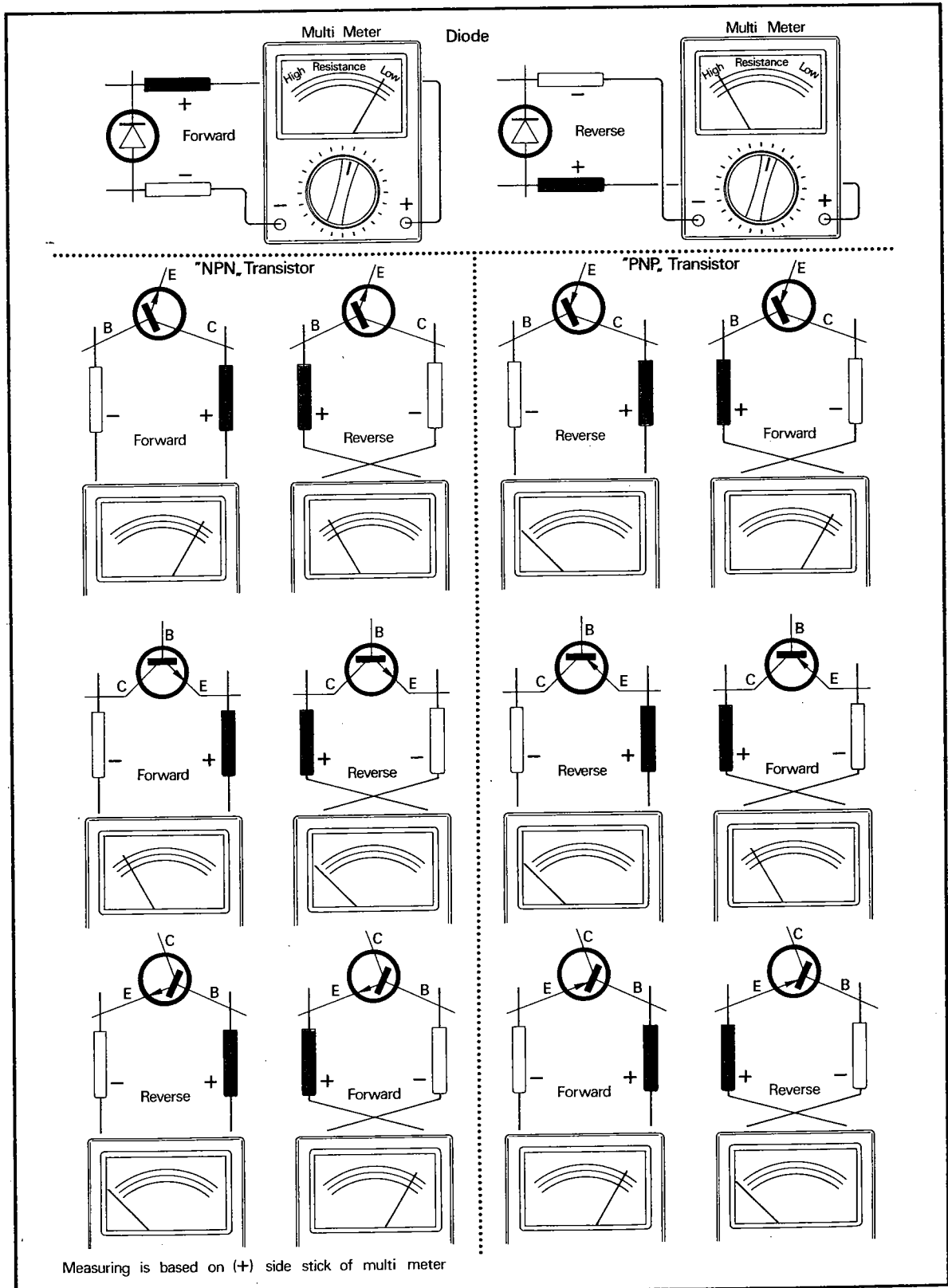



COLOR-CODING CHART

Color	Common to All PARTS			Fixed Resistor	Mica Capacitor				Paper Capacitor		Ceramic Capacitor			
	1st Figure	2nd Figure	Multiplier	Allowance (%)	Grade	Property	Allowance (%)	Rated Voltage (V)	Grade	Rated Voltage (V)	Grade	Property	Allowance (%)	Rated Voltage (V)
Black	0	0	1		X	A	± 20 (M)		±20(M)	100	X		± 20	
Brown	1	1	10 ¹ (10)			B			± 5 (J)	200				
Red	2	2	10 ² (K)	± 2	Y	C	± 2 (G)		± 2 (G)	250	Z			250
Orange	3	3	10 ³			D		300						
Yellow	4	4	10 ⁴			E			±15 (L)	400				
Green	5	5	10 ⁵ (M)			F	± 5 (J)	500	+20(V) -15					500
Blue	6	6	10 ⁶						+40(X) -15	600			+100 -1	
Purple	7	7	10 ⁷											
Grey	8	8	10 ⁸		Z				+10(Y) -15		(Y)			
White	9	9	10 ⁹					1000	±10(X)	1000		YY YZ		
Gold			10 ⁻¹ (0.1)	± 5										
Silver			10 ⁻² (0.01)	± 10										
non-colored				± 20										

CARBON RESISTOR

Note: *Solid resistor is marked from here.

MICA CAPACITOR

PAPER CAPACITOR

CERAMIC CAPACITOR

The color code indicates figures 1 to 9 by the use of 10 different colors. It is in agreement with IEC and JIS.

Property	Temperature Coefficient	Divergence of Capacity	Q tan δ	Insulation Resistance
A	Not specified	Not specified	0.5 under	3000MΩ under
B	Not specified	Not specified		
C	-20—+200	±(0.5%+0.5PF)	} 0.5 over	7500MΩ over but 0.1 over 3000MΩ over
D	-100—+100	±(0.3%+0.1 PF)		
E	-20—+100	±(0.1%+0.1 PF)		
F	0—+70	±(0.05%±0.1PF)		

Grade	Usable Temperature Range	Test Classification
X	-55—+85	1 or 11
Y	-30—+85	1 or 11
Z	-30—+85	1

Letter	Allowance
G	± 2
T	± 5
K	± 10
M	± 20

1st & 2nd Figure	3rd Figure (Multiplier)	Allowance (%)	Rated Voltage (V)	FILM CAPACITOR * (101—100PF M—± 20% 1H—50V)
0 * 9	0	1 (PF)	1A 10	
	1	10 ¹	1E 25	
	2	10 ²	1H 50	
	3	10 ³	2A 100	
	4	10 ⁴	2E 250	
	5	10 ⁵ (μF)	Z + 80 - 20	
	6	10 ⁶	P + 100 - 0	



TECHNICAL TIPS

Information for your Service Department
Prepared and Distributed by Dokorder Inc., Service Dept.

TABLE OF CONTENTS

1. **PRINCIPLES OF SPECIAL CIRCUITS – ECHO/SOUND-ON-SOUND RECORDING**
 - 1-1. ECHO RECORDING
 - 1-2. SOUND-ON-SOUND RECORDING

 2. **EXPLANATION ABOUT EASY-LOADING MECHANISM**
 - 2-1. MECHANICAL OPERATION
 - 2-2. CIRCUIT OPERATION IN PLAY OPERATION

 3. **DETAILED EXPLANATION OF REEL TABLE HEIGHT ADJUSTMENT MECHANISM**
 - 3-1. ADJUSTMENT IS NECESSARY WHEN
 - 3-2. REEL TABLE HEIGHT MECHANISM
-



PRINCIPLES OF SPECIAL CIRCUITS

ECHO/SOUND-ON-SOUND RECORDING

The actual operation for Echo and Sound-on-Sound recording is shown in Owner's Reference Book, supplied with the tape recorders equipped with the appropriate circuits. The following explains the principles and electrical functions of such special circuits.

1-1. ECHO RECORDING

Read the following explanations, referring to the accompanying block diagram (Figure 1-1). Though Figure 1-1 shows part of the circuit, i.e. only for the left channel, the circuit for the right channel is identical.

1. Assume that the tape is running at a speed of V cm/sec. in the direction of the arrow and that the distance between the gaps of the RECORD HEAD (A) and the PLAY HEAD (A') is D cm, then a signal, recorded by the RECORD HEAD, will be picked up by the PLAY HEAD ' D/V ' seconds after.
2. The detected signal will then be amplified by the PLAYBACK AMPLIFIER, its level adjusted properly by the ECHO LEVEL CONTROL, filtered by the BAND PASS NETWORK, amplified again by the RECORD AMPLIFIER and recorded again by the RECORD HEAD.
3. Thus the first signal is recorded or dubbed over a second signal that passes the RECORD HEAD (A) ' D/V ' seconds after, and at a point D cm away from the point A'.

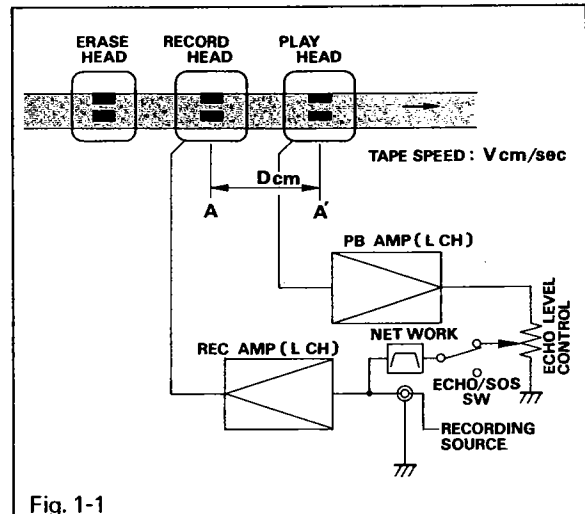

Fig. 1-1

4. For instance, with the Model 9200 whose RECORD HEAD/PLAY HEAD distance (D) is 3cm, when the tape is running at 19cm/sec., the time between when a recorded signal is picked up by the PLAY HEAD and when it is re-recorded by the RECORD HEAD, or echo time, is 0.15 second. Likewise, when the tape is running at 9.5cm/sec., the echo time is 0.3 second.
5. Since the echo circuit is a type of feedback system that has the running tape as part of the circuit, oscillation may occur when a greater than necessary amount of echo level or feedback is applied; the appropriate amount of echo should be added according to the level of signals. (See Figure 1-2 (A)) Thus, during a recording with the echo level set at an unreasonably high position, oscillation may occur when a high-level signal is suddenly applied. (See Figure 1-2 (B)) Therefore, while recording, especially high-level recording, monitoring is necessary to check the most appropriate amount of echo is added to the recording.

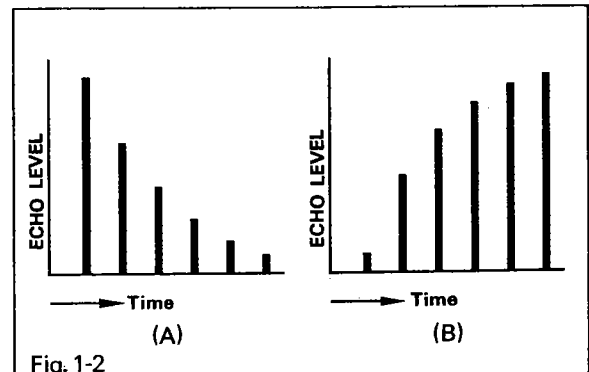

Fig. 1-2



NOTES

1. Since echo is added to a second signal 'D/V' seconds after the first signal is recorded, adding echo in the playback operation is impossible.
2. Since the tape is a part of the echo-generating feedback circuit, tape is necessary even when the tape deck functions as an echo machine.
3. Since echo is recorded on the tape, the same amount of echo is heard during tape playback.
4. The echo time can be selected by changing tape speeds.
5. The left signals can create echo for the left channel, and the right signals, for the right channel. Echo recording is possible only with the tape decks that have independent ERASE, RECORD and PLAY heads.

—1-2. SOUND-ON-SOUND RECORDING—

Read the following explanation regarding the principle of sound-on-sound recording, referring to the accompanying block diagram (Figure 1-3). The tape is running from left to right. Assume that the RIGHT MONITOR SWITCH and the LEFT RECORD SWITCH are depressed and that a signal is already recorded in the left channel (Track 1):

1. The signal recorded on Track 1 (////) will be picked up by the PLAY HEAD, amplified by the LEFT PLAYBACK AMPLIFIER, its level adjusted, and fed to the RIGHT RECORD AMPLIFIER.
2. At the same time, another signal (\\\\\\), fed through the right input, will be fed to the RIGHT RECORD AMPLIFIER and combined with the first signal. The resultant signal will then be fed to the RECORD HEAD.
3. As the result, the combined first and second signals (XXXX) are recorded in the right channel (Track 3).
4. When the LEFT MONITOR SWITCH and the RIGHT RECORD SWITCH are depressed, addition of a third signal is possible. By repeating the above-mentioned procedure, dubbing a fourth, fifth signal and so forth is also possible.
5. To synchronize one recording with another new one such as when singing to the already recorded music, monitoring of the first signal is necessary.
6. Sound-on-sound recording is possible only with the tape decks that have independent ERASE, RECORD and PLAY heads.

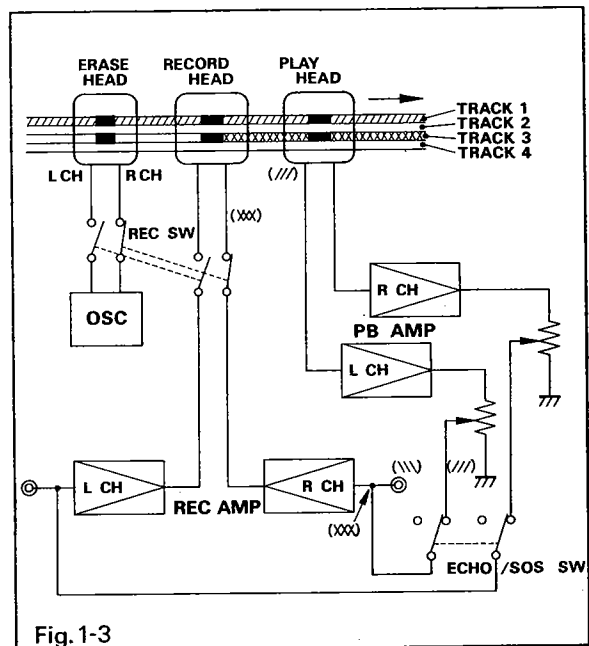

Fig. 1-3

NOTE

With 4-channel tape decks such as the Model 7140, both echo and sound-on-sound recording are possible only with the front channels (Tracks 1 and 3), not with the rear channels (Tracks 2 and 4).



EXPLANATION ABOUT EASY-LOADING MECHANISM

On Dokorder tape decks such as the Models in 7000 series and 9200, a newly-developed easy-loading mechanism is incorporated to allow the user to thread the tape smoothly and easily. The following is an explanation about the Dokorder easy-loading mechanism.

2-1. MECHANICAL OPERATION

A feature of the Dokorder easy-loading system is that the PRESSURE ROLLER remains beneath the tape path in the STOP mode. That is, the PRESSURE ROLLER raises and presses against the PINCH ROLLER only when the PLAY BUTTON is depressed. As the PRESSURE ROLLER always remains below the tape path, a tape can be easily threaded without difficulties. Also, due to the sequential operation by the electronically-controlled solenoid plungers, the mechanical operation is performed almost instantaneously. Refer to the Figures 2-1 and 2-2.

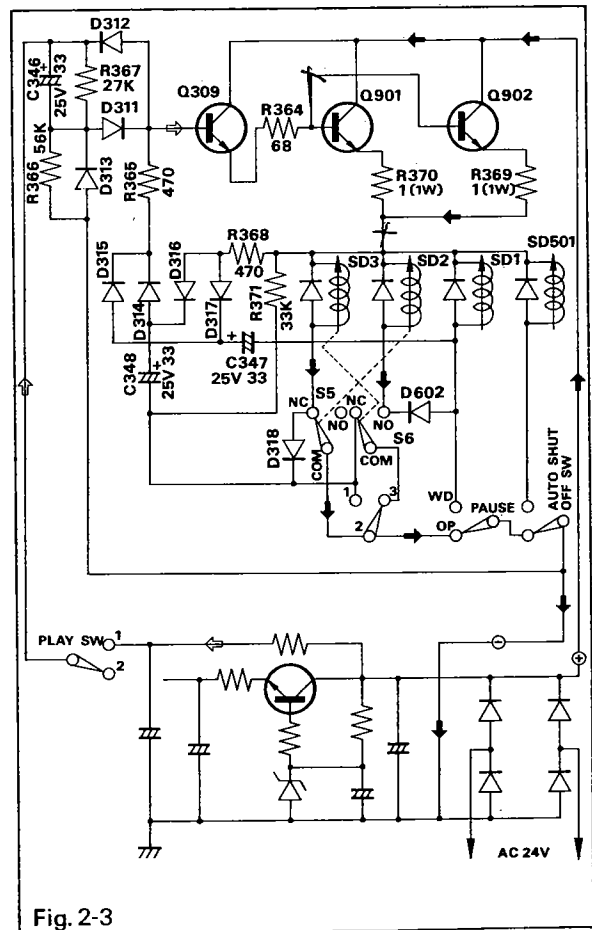
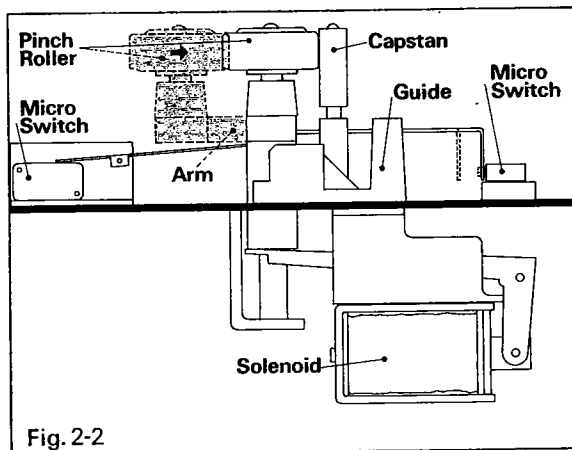
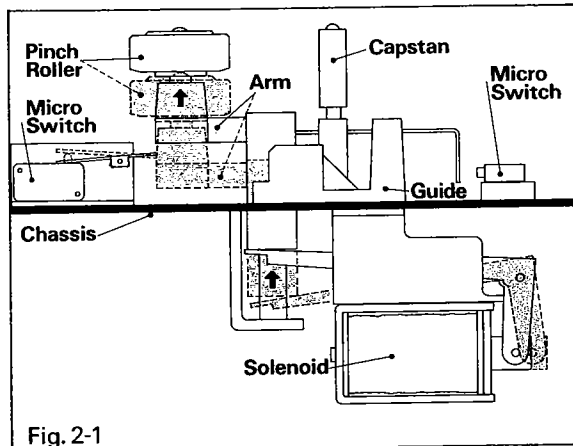



—2.2. CIRCUIT OPERATION IN PLAY OPERATION—

The explanation of the circuit operation in the PLAY mode is as follows. The Figure 2-3 shows the circuit of the Model 7200.

1. When the PLAY BUTTON is depressed and the play switch is set to position 1, a current flows in the direction of the arrow (\Rightarrow) to C346 and D311, and almost instantaneously a voltage of about 30V is applied to the base of Q309.
2. Then Q901 and Q902 result in a conducting state, and a current flows in the direction of the arrow (\Rightarrow), activating the PUSH-UP SOLENOID SD3.
3. When SD3 is activated, the PRESSURE ROLLER, together with the ARM, is pushed up by the lever connected to the plunger, and then S6 is switched to the N.O. position by the actuator connected to the ARM. Then current flows through SD2, allowing the PRESSURE ROLLER to press against the CAPSTAN. Next, SD3 is de-activated when S5 is switched to the N.O. position.
4. At the same time, current flows through D602 and S6 to SD1, disengaging the brake mechanism and allowing the tape to run.
5. The voltage, applied to the base of Q309 when the PLAY BUTTON is depressed, decreases with the lapse of time according to the time constant decided by the ratings of C346 and R367. It finally results in a constant voltage of 15V, which has been divided by R367 and R366, in about one second.
6. As the result, the voltage, applied to the base of Q901 and Q902 and controlled by Q309, reduces from 30V to about 14V. Consequently, the voltage, applied to the emitter of Q901 and Q902, decreases to about 13.5V. Likewise, the voltage, applied to SD2 and SD3, decreases to 13.5V.
7. Because of the reduced voltage, SD2 and SD3 always remain activated, and heat generated by the coils in the solenoids is kept to a minimum. As the result, the operation of the solenoids is always positive and stable; there is less heat generated by the coils in the solenoids and therefore less increase in resistance.

Parts unrelated to the explanation are omitted from the illustration shown. And though this is the circuit for the Model 7200, the basic operations are the same for the Models 7500, 7140 and 7100, too.



DETAILED EXPLANATION OF REEL TABLE HEIGHT ADJUSTMENT MECHANISM

Reel table height can be adjusted on Dokorder Models 7500, 7200, 7140, and 7100. Adjustment procedure is explained in the Owner's Reference Book, supplied with each Model. The following is the detailed explanation of this unique reel height mechanism.

3-1. ADJUSTMENT IS NECESSARY WHEN:

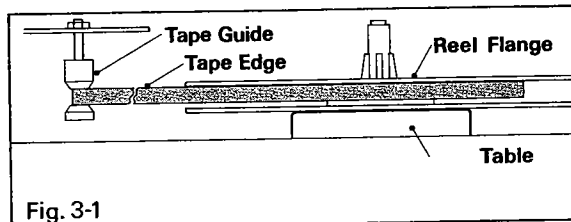

Fig. 3-1

Tape scraping the upper flange of a reel; the reel height must be increased.

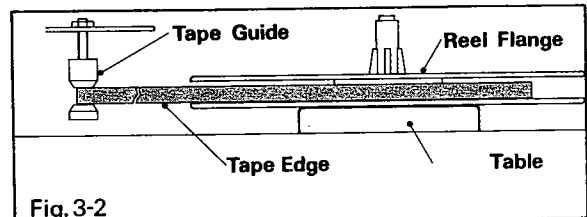

Fig. 3-2

Tape scraping the lower flange of a reel; the reel height must be reduced.

3-2. REEL TABLE HEIGHT MECHANISM

LOCKING SCREW ① fastens PINION GEAR-COUPLED SCREW ③; PINION GEAR-COUPLED SCREW ③ gears with the RACK inside the REEL TABLE RING ⑤; the RACK gears with TABLE HEIGHT SCREW ④. Therefore, when PINION GEAR-COUPLED SCREW ③ is turned, REEL TABLE RING ⑤ moves up or down. To adjust the reel table height, first remove LOCKING SCREW ①, turn the head of the PINION GEAR-COUPLED SCREW ③ to left or right with a screwdriver while holding the FINS ⑥. To increase the height, turn the screwdriver counterclockwise; to decrease it, turn the screwdriver clockwise. REEL TABLE RING ⑤ can turn up to 180 degrees toward the left or right. A 180-degree turn increases or decreases the height by 1mm. The adjustment may be impossible when an unusually disfigured reel is used; such a reel should be replaced by a new one.

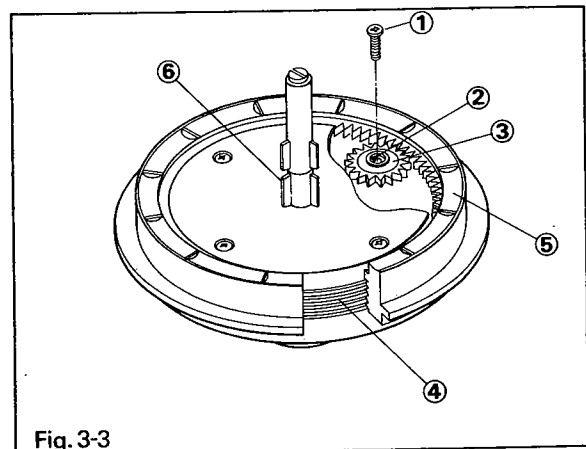

Fig. 3-3

Since PINION GEAR-COUPLED SCREW ③ is fragile, be sure to select a screwdriver that securely fits the minus-headed screw head, otherwise the head may be unreparably damaged.

