



## **THE KITBOOK**

---

# **FROY**

## **2-WAY D'APPOLITO**

### **11 LITRES, 140 / 400 WATTS**

The FROY is a high quality 2-way system using SEAS top of the line Excel drive units. It utilizes 2 W14CY001 magnesium cone woofers and a single T25001 fabric dome tweeter mounted in a D'Appolito configuration.

The D'Appolito configuration in this kit offers a number of advantages over standard single-woofer designs. These include :

- \* Controlled vertical directivity in the midrange which reduces the effect of floor and ceiling reflections.
- \* Excellent imaging and spacial characteristics.
- \* Higher system sensitivity.
- \* Lower distortion.
- \* Increased bass output.

The cabinet is designed with a minimum front baffle area to reduce diffraction effects. The port tube is constructed of two MDF boards which also serve as additional bracing for the cabinet. The port is placed in the middle of the cabinet and the port exit is to the rear. This technique ensures that each of the drive units will have symmetrical bass loading. The bass loading utilizes a sub-chebychev filter for minimum group delay.

The crossover network has been configured to yield an acoustic 4th order Linkwitz-Riley crossover at 2.5kHz. The network also includes 2 L-C networks connected directly at the woofer terminals which eliminate the high frequency peak caused by the breakup mode of the magnesium cone. The tweeter crossover section includes equalization and impedance linearization networks.

The FROY produces a very accurate and detailed sound stage with superb imaging capabilities. Bass performance is also surprisingly powerful and deep for such a small enclosure. In the tradition of the best mini-monitors, this system is capable of revealing the good and the bad aspects of both the source material and the electronic components. It is recommended that a high quality amplifier with the capability of driving loads of 4 ohm or less be used with this system.

The FROY was designed in the USA by Murray Zeligman, president of Zeligman Electronic Labs. Mr. Zeligman is an independent consultant with more than 25 years experience in the design of loudspeaker systems and audio amplifiers. He is responsible for a number of highly succesful commercial loudspeaker designs. This system was designed through extensive use of the LEAP and LMS computer based simulation programs. Final "voicing" of the system was accomplished through extensive listening tests.

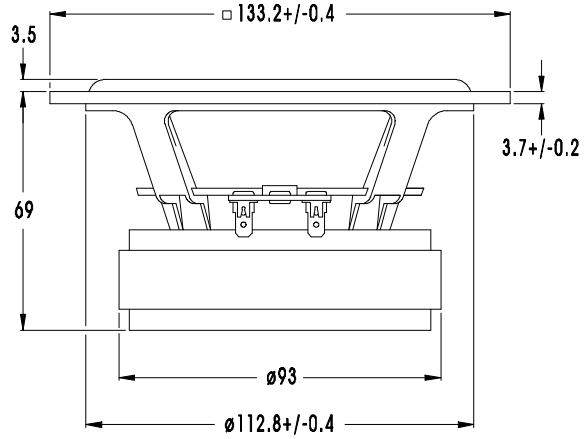
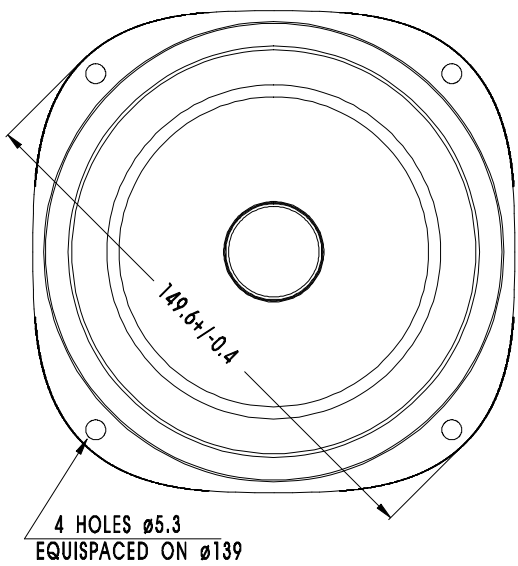

W14CY001 is a 5 " Woofer/Midrange unit with an extremely stiff, yet light injection moulded magnesium cone which gives tremendous bass precision and midrange detail.

Other features :

- \* Heavy copper rings and phaseplug, mounted in the magnet system to reduce distortion.
- \* Stiff and stable injection moulded chassis from high purity magnesium.
- \* Gold plated terminals for long term stability.
- \* Copper plated top and bottom plates.

T25 001 is a 25mm fabric dome tweeter with a stiff 6mm machined aluminium chassis. The unit features moderately high efficiency and smooth, extended response due to an optimum shaped SONOTEX diaphragm.

Other features :

- \* Silver wire voice coil to improve electrical conductance.
- \* Flexible lead out wires.
- \* Gold plated terminals for long term stability.
- \* Low viscosity magnetic fluid with good cooling effect.
- \* Complex internal damping and injection moulded rear chamber.

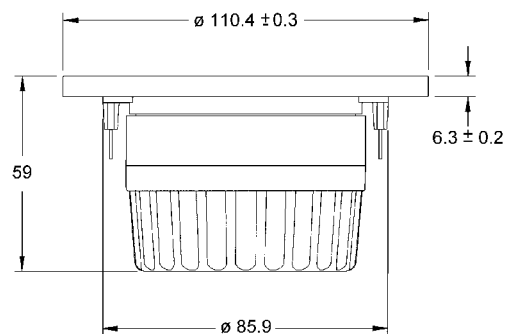
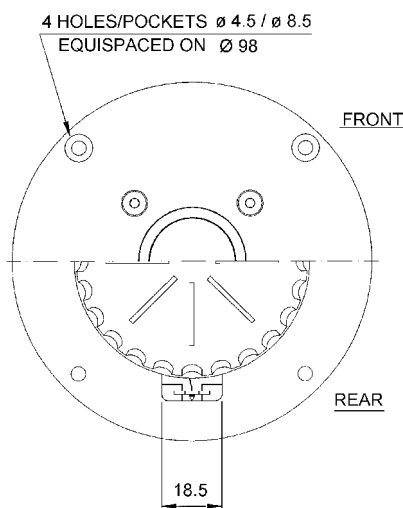

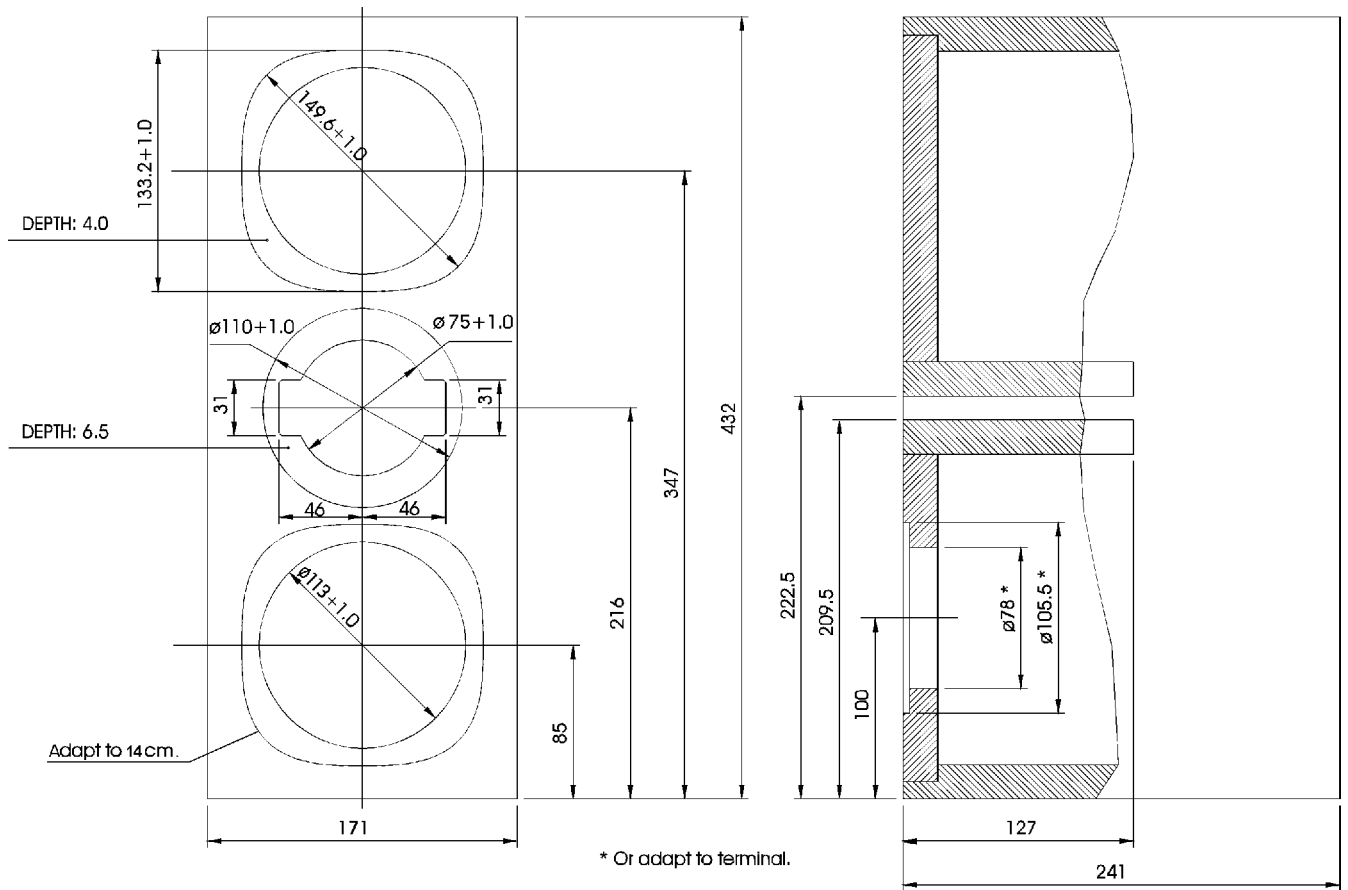

All measurements in mm

**MATERIAL :** 19mm MDF

**DAMPING :** Minimum 50 mm open cell foam on all walls except front

**BASS PORT :** Built into the cabinet

A chamfered or rounded edge around the front baffle will reduce edge reflections which cause irregular sound radiation in the upper frequency range, especially on axis.

# CROSSOVER

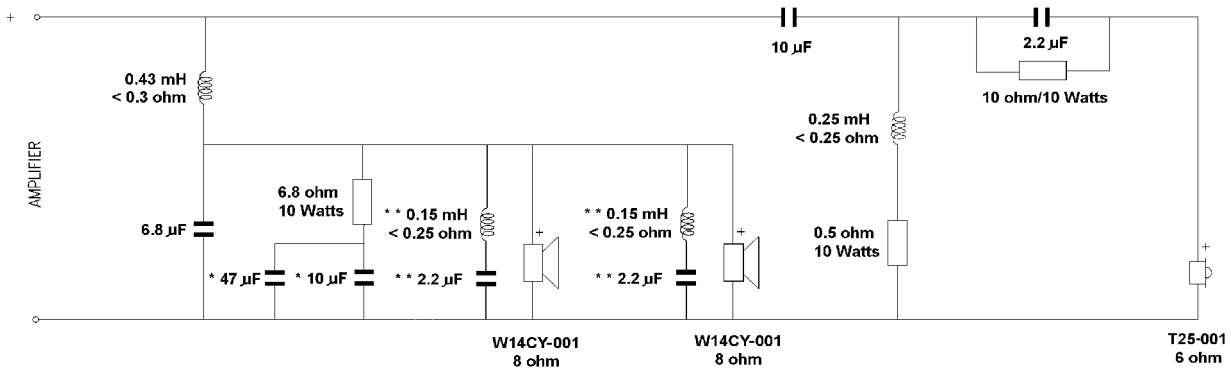

- All resistors are 10 watt wirewound 5% tolerance.
- All capacitors are polypropylene film 100 v unless otherwise noted.
- All coils are air core type.

\* = NP electrolytic, 100v

\*\* = These components are located directly at the speaker terminals.

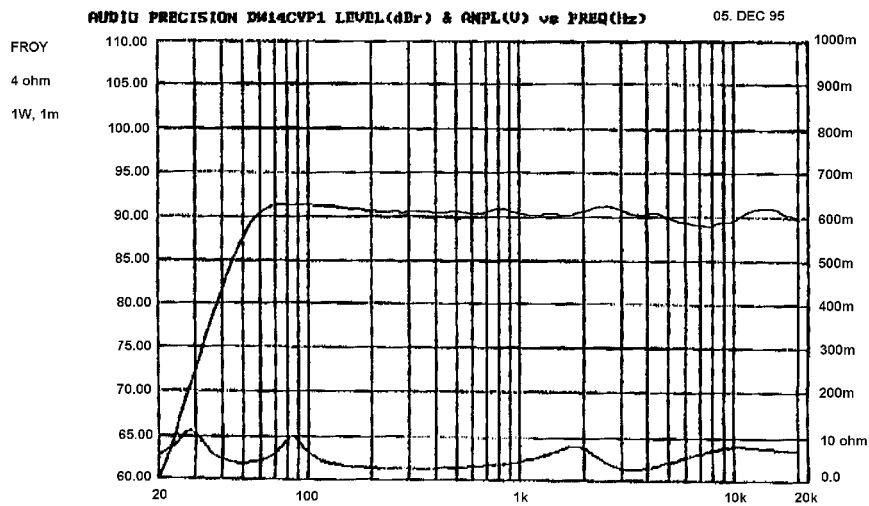

## TECHNICAL DATA

IMPEDANCE	4	Ohms
SHORT TERM MAX. POWER *	400	W
LONG TERM MAX. POWER *	140	W
CROSSOVER FREQUENCY	2500	Hz
FREQUENCY RANGE	50-25000	Hz

\* = IEC 268-5

SENSITIVITY	90.0	dB SPL
OPERATING POWER	4,0	W
RECOMMENDED AMPLIFIER	50-400	W
DIMENSIONS	171x432x241	mm
CABINET VOLUME	11	Litres

SEAS reserves the right to change technical data.