

Meeting the challenge of digital sources

GX-8/GX-6

3-Head Stereo Cassette Deck

The digital revolution has made better quality analog equipment a must. CD music with its high dynamic bass output poses a special recording challenge to tape decks. Akai has met this challenge with the GX-8 and GX-6.

Improvements in the power source

The power source for the amp, and noise reduction, is now independent of the main circuitry, resulting in full amp reinforcement – vital for reproducing powerful bass. Twin active power sources provide ideal power supply stability.

Twin Active Power Supply: Block Diagram

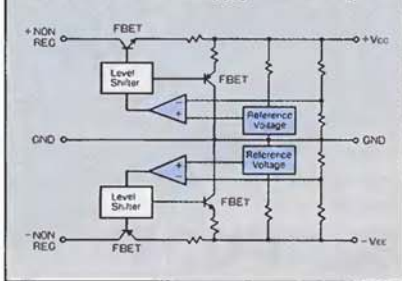

Improved amplifier circuitry

Dynamic range and resolution in high frequencies have been substantially increased as well by the installation of pure DC amplifier circuitry. Transmission distortion in the musical signal path is almost nonexistent due to the use of Linear Crystal Oxygen-Free Copper. No feedback, push-pull current drive circuitry is employed in the recording amp, diminishing phase distortion stemming from voltage-



impedance conversion due to related resistance.

Low-noise high speed dual FET input amp employed in the playback equalizer amp yields a high slew rate and low distortion.

Closed loop double capstan system by direct drive

In order to maintain ideal tape tension and optimum head-to-tape contact, both decks employ a closed loop double capstan tape transport. The GX-8 features a quartz lock servo circuit for even greater rotational stability. This system provides excellent performance with modulation noise from 0–20 kHz, improved by as much as 5 dB over single capstan models.

Super GX 3-head system using Linear Crystal Oxygen-Free Copper

Super GX heads provide excellent

performance that fully exploits the advantages of the 3-head setup. Linear Crystal Oxygen-Free Copper used in wiring reduces signal transmission distortion and provides better electrical linearity.

Sound Quality Assured by dbx

Originally developed for the recording industry, dbx has long been favored by professional recording engineers for its ability to

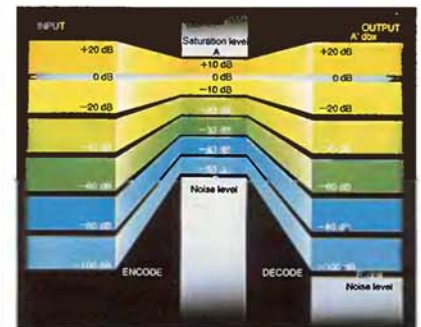

Super GX Head with LC-OFC

A 3-head system is definitely the choice of those desiring the very finest reproduction available from a home stereo component system. It has completely separated gaps—one exclusively for recording and another exclusively for playback. And Akai was able to optimize the design for truly excellent performance. A four micron recording gap-width and a one micron playback gap-width optimize magnetic field-strength during recording, assuring broad frequency response characteristics during playback with virtually no azimuth

loss.

The Twin Field Super GX Head also has separated gaps for recording and playback. Therefore the performance is almost equal to a 3-head system except for monitoring of the just-recorded signal. Linear Crystal Oxygen-Free Copper used in wiring reduces signal transmission distortion and provides better electrical linearity. This gives better recording purity, extended frequency response and wider dynamic range for rich resonance; the feeling of live sound.

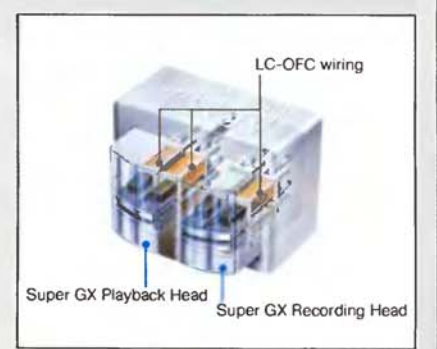



GX-8

not only reduce tape noise, but also increase the headroom and the effective dynamic range of the recording tape without overloading it and causing unwanted distortion. During recording, dbx compresses the dynamic range of the signal, letting louder passages be recorded without overload distortion. Playback/expansion releases the full dynamic

range of the original signal source while simultaneously suppressing tape noise; pushing it down, well below audible limits. With such an expanded dynamic range, even powerfully dynamic digital sources can be successfully recorded and reproduced to deliver their full sound potential.

Other convenient features

Bias control, anti-resonance construction, dbx (GX-8 only) and double process Dolby B/C NR system, Auto Monitor system, Quick and Quiet mechanism, 3-way, 4-digit electronic counter, 17-segment, 2-color peak meter, and computer search functions achieve a sensitive, upgraded operation.

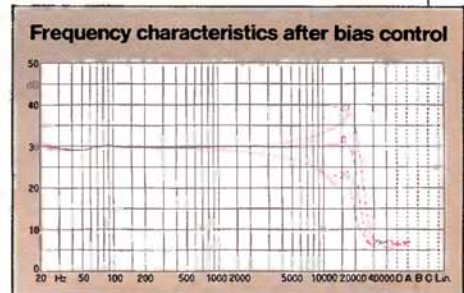

GX-6

Closed Loop Double Capstan System by Direct Drive

In this sophisticated system, two pairs of capstans and pinch rollers isolate the tape near the heads. This stabilizes tape tension and speed at the point of head contact, regardless of irregularities in the reels. A direct drive system uses an FG servo motor to turn the capstan to maintain stable tape tension at all times. The GX-8 features a quartz lock servo circuit for even greater rotational stability. The capstans are processed with Akai's Inverse Current Hard Chrome finish for

extra durability and running precision. The result of all these improvements is optimum head contact, highly accurate

Closed Loop Double Capstan by DD System

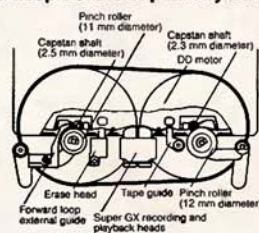

tape transport, and a minimum of modulation noise that can cause distortion.

Modulation Noise Characteristics

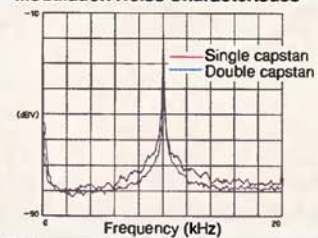

Giving you the right solutions for digital demands



GX-52

Stereo Cassette Deck

Akai's new GX-52 stereo cassette deck has the quality you need to meet the stringent demands of today's digitally-recorded music. Extremely low levels of noise and wow/flutter, and enhanced speed accuracy are achieved using direct drive tape transport. Improved frequency response and dynamic range result

from the precision-designed Twin-field Super GX head with high purity LC-OFC wiring, pure DC amplifier circuitry and the Dolby HX-PRO which lowers bias levels resulting in more headroom for high-frequency recording. Other advanced features include micro-processor control (for high-precision editing, quick start-up and quiet operation with feather light touch), Dolby B/C NR, manually

adjustable bias, Direct Lead-in and Power Eject (automatically loads the tape and begins selected operation), IPSS (Instant Program Search System), auto play, peak level meter that automatically displays the appropriate values for the type of tape in use and a large, high-visibility, variable FL display (gives real time display and selection number display during IPSS operation).

HX-A201

Stereo Cassette Deck

HX-A201 has been given a bold new design, with slim dimensions. Outstanding features are Dolby B/C NR system, HD head, One-touch recording, LED peak level meter and soft-touch controls.



HX-A101/M

Stereo Cassette Deck

The HX-A101M is a Dolby B NR deck with many of the same outstanding features of the HX-A201. The HX-A101 features Normal/CrO₂ tape capability in a design similar to the HX-A101M.



Dolby HX PRO

This system allows lowered bias levels which result in more headroom for high-frequency recording. During recording, the Dolby HX PRO monitors the recording signal. When high frequency peaks are detected, bias is reduced to accommodate them; when these peaks are no longer

present, bias is restored to the normal level.

The system improves recording saturation levels, so that even normal tapes attain high-frequency signal levels that approach those of CrO₂ and metal tape performance.

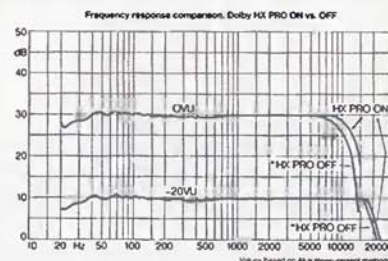



HX-A451W

Double Cassette Deck

Here are all the functions you need to dub and edit programs, and create tapes just the way you want them. The perfectly matched twin cassette drive mechanisms are powered by a high torque motor that ensures precise dubbing from the source tape. You can do one-touch dubbing at both the same speed and at double speed, and tape editing can be accomplished twice as quickly. Akai's random program selection lets you play tape selections in any order you choose on either tape one or tape two by pressing only a single button: you can make a total of 15 programs with 12 selections.

The HX-A451W also features an

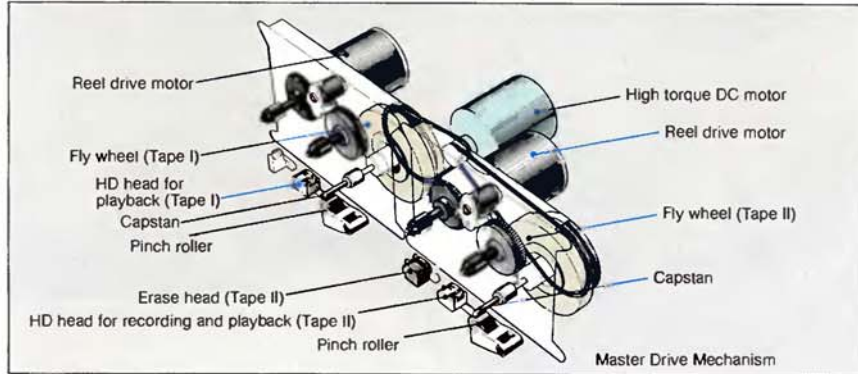

innovative continuous play function. During operation, playback switches automatically from tape one to tape two and vice versa. Additional features include: a Dolby B/C NR

system, HD (High Density) head, BPS (Blank Skip Play System), Intro Scan, auto play, IPLS, 2-way digital display, LED peak level meter and timer start function.

HX-A351W

Double Cassette Deck

The HX-A351W also features perfectly matched twin cassette mechanisms. Dubbing from the source tape is precise, with virtually no deterioration in sound quality. The high speed dubbing mode allows tape dubbing in half the normal playback time. And one-touch dubbing means operation is simple. The convenient continuous play function means that during operation, playback switches automatically from tape two to tape one. The HX-A351W

also incorporates the Dolby NR system ensuring superior sound quality by reducing tape hiss to an inaudible level. HX-A351W also

includes: one-touch recording, HD head, LED peak level meter and Timer start function



Features

Rec Cancel

returns the most recent recording start point, and switches into record standby

Intro Scan

plays the first 10 seconds (approx.) of each selection in order.

IPLS (Instant Program Location System)

moves automatically in either direction.

Auto Play

automatically begins play after rewind.

Auto Monitor

automatically switches from source monitor in record standby to tape monitor in record mode.

Auto Mute

automatically creates a 4-second space between selections.

Auto Tape Selector

checks cassette and automatically selects appropriate tape position.

Direct lead-in and power eject

Just place a cassette in the cassette compartment and press any operation button for power loading. Press the eject button and AKAI's unique power eject system ejects the cassette.

Crystal-clear, super dynamic Hi-Fi sound Quick

GX-R70EX/ GX-R60EX

Quick Reverse Cassette Deck

Akai presents the GX-R70EX and GX-R60EX with features and performance that truly deserve the description 'ready for digital'. The Twin Field Super GX head with Linear Crystal Oxygen-Free Copper

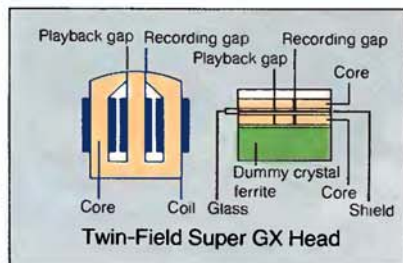

coils offers outstandingly flat frequency response. The LC-OFC coils extend bass response to bring out the rich tones made possible by



Conventional copper crystals



LC-OFC crystals

digital sound sources. High precision, Quick Reverse system gives you hours of uninterrupted playback and extended recording convenience, allowing you to take advantage of the longer program times available from digital sources. A dbx noise reduction system increases headroom, allowing the full dynamic range of digitally recorded music to come through. Both Dolby B/C NR systems have also been included.

CRLP (GX-R70EX only) sets super accurate recording levels at the touch of a button. Other outstanding features include; high-speed DC amplifier for superb recording



linearity, 2-speed auto fader, real-time tape counter, IPLS, anti-resonant rubber feet, direct lead-in and power eject.



Quick Reverse – BSP Mechanism

To ensure stable tape transport in either direction, Akai uses the BSP (Bi-directional Symmetrical Precision) mechanism. This mechanism is designed to provide a perfectly symmetrical tape path in either direction, and it compensates for variation in cassette shells and tape dimensions by using the Dual Wide Tape Guide system. In this system, separate tape guides are



BSP Mechanism

positioned on either side of the record/playback head to prevent uneven tape-to-head contact and resulting tape curling and wear. Dropouts and level fluctuations are dramatically reduced for superb sound in either direction.

Quick Reverse – Accurate Reverse Head System

Akai's Quick Reverse system obstructs the tendency toward misalignment in

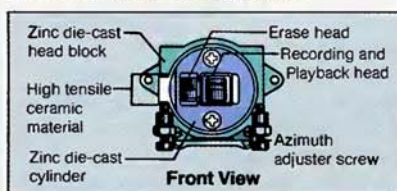

conventional head designs. That's why Akai insists on extra strong head construction materials. The head housing for example is made of beryllium-alloyed die-cast zinc, so tough that head rotation shocks leave no mark. Instead of fluid lubricants, solid Teflon is employed together with a special temperature resistant polyamide resin, achieving a service life of 2 million rotation cycles. Diamond-class extra hard fine ceramic head stoppers 'cushion' the head with impact resistance rated at 22,000 kg/cm². Tempered stainless steel azimuth screws maintain exactly the correct head gap-to-tape angle in both directions. Last but not least, the wires from the circuitry to the rotary head are incorporated into a flexible printed circuit board that doesn't wear out like ordinary head connections.

Quick Reverse

GX-R70EX

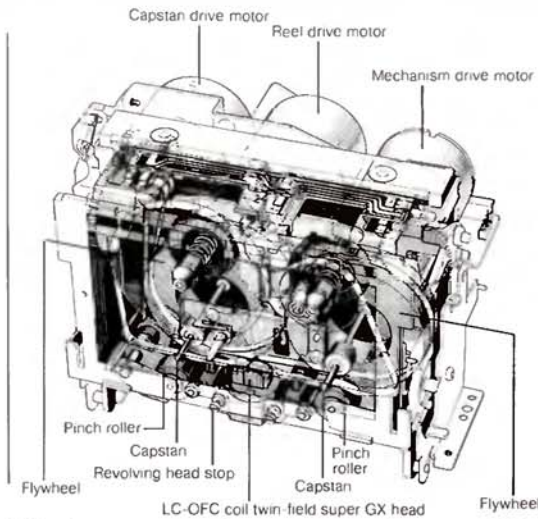

HX-R40

Quick Reverse Cassette Deck

High-precision Quick Reverse tape transport. Dolby B/C NR system. Intro scan and IPLS. 3-position tape selector. Timer start switch.



CRLP (Computer Recording Level Processing) sets super accurate recording levels at the touch of a button

The GX-R70EX/R70 feature Akai's unique CRLP for the easiest, most accurate setting of recording levels. Using the power of a microprocessor, the CRLP system electronically sets the correct recording level in seconds, at the touch of a button. First, CRLP determines the MML (Maximum Modulation Level) and SOL (Saturation Output Level) of the tape in use and then ascertains the overload level and MOL (Maximum Output Level) characteristics. Next the tape's MOL is compared with the input signal level which is attenuated in 1 dB steps until the

optimum level is reached. Then an electronic variable resistor is set to this optimum record level, which is clearly shown on the FL display for reference. This level can also be overridden using the manual record level controls.

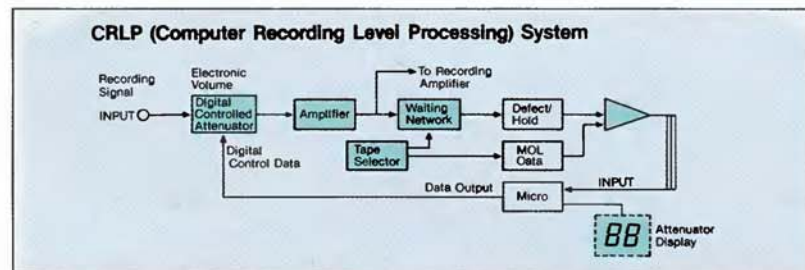

CASSETTE DECK

MODEL	GX-8	GX-6	GX-R70EX/R60EX	GX-52
Motors	Quartz PLL DD Motor for capstan drive ×1, DC Motor for reel drive ×1, DC Motor for cam & door drive ×1	FG Servo DD Motor for capstan drive ×1, DC Motor for reel drive ×1, DC Motor for cam & door drive ×1	Electronically speed controlled DC Motor for capstan drive ×1, DC Motor for reel and lid drive ×1, DC Motor for cam drive ×1	FG servo DD Motor for capstan drive ×1, DC Motor for reel drive ×1, DC Motor for cam and lid drive ×1
Heads	LC-OFC Super GX Head for recording ×1, LC-OFC Super GX Head for playback ×1, Erase Head ×1	LC-OFC Super GX Head for recording ×1, LC-OFC Super GX Head for playback ×1, Erase Head ×1	LC-OFC Twin Field Super GX Head for recording and playback ×1, Erase Head ×1	LC-OFC Twin Field Super GX Head for recording and playback ×1, Erase Head ×1
Wow & flutter	0.025% WRMS, 0.04% (DIN)	0.025% WRMS, 0.04% (DIN)	0.05% WRMS, 0.12% (DIN)	0.027% WRMS, 0.045% (DIN)
Distortion (Metal)	0.6%	0.6%	0.8%	0.8%
Frequency response Metal CrO₂ Normal	20–21,000 Hz ±3 dB 20–20,000 Hz ±3 dB 20–19,000 Hz ±3 dB	20–21,000 Hz ±3 dB 20–20,000 Hz ±3 dB 20–19,000 Hz ±3 dB	20–19,000 Hz ±3 dB 20–18,000 Hz ±3 dB 20–17,000 Hz ±3 dB	25–20,000 Hz ±3 dB 25–18,000 Hz ±3 dB 25–17,000 Hz ±3 dB
S/N (Metal)	60 dB: Dolby C NR ON; Improves up to 15 dB at 500 Hz, 20 dB at 1 to 10 kHz, Dolby B NR ON; Improves up to 5 dB at 1 kHz, 10 dB above 5 kHz	60 dB: Dolby C NR ON; Improves up to 15 dB at 500 Hz, 20 dB at 1 to 10 kHz, Dolby B NR ON; Improves up to 5 dB at 1 kHz, 10 dB above 5 kHz	60 dB: Dolby C NR ON; Improves up to 15 dB at 500 Hz, 20 dB at 1 to 10 kHz, Dolby B NR ON; Improves up to 5 dB at 1 kHz, 10 dB above 5 kHz	59 dB: Dolby C NR ON; Improves up to 15 dB at 500 Hz, 20 dB at 1 to 10 kHz, Dolby B NR ON; Improves up to 5 dB at 1 kHz, 10 dB above 5 kHz
Dynamic Range	110 dB (dbx ON)	—	110 dB (dbx ON)	—
Dimensions	440(W)×111(H)×353(D)mm (17.3×4.4×13.9 inches)	440(W)×111(H)×353(D)mm (17.3×4.4×13.9 inches)	440(W)×115(H)×280(D)mm (17.3×4.5×11.0 inches)	425(W)×112(H)×352(D)mm (16.7×4.4×13.9 inches)
Weight	6.5 kg (14.3 lbs)	6.5 kg (14.3 lbs)	5.2 kg (11.5 lbs) (GX-R70EX) 5.0 kg (11 lbs) (GX-R60EX)	6.5 kg (14.3 lbs)