

TA-FE320R/FE520R

SERVICE MANUAL

AEP Model
TA-FE320R/FE520R

UK Model
TA-FE320R



Photo: TA-FE520R

SPECIFICATIONS

Amplifier section

DIN power output

TA-FE520R: 100 W + 100 W (4 ohms at 1 kHz)
85 W + 85 W (8 ohms at 1 kHz)
TA-FE320R: 60 W + 60 W (4 ohms at 1 kHz)
50 W + 50 W (8 ohms at 1 kHz)

Frequency response

PHONO (20 Hz - 20 kHz): RIAA equalization curve
 ± 1.0 dB
TUNER, CD, AUX, TAPE1/DAT, TAPE2/MD:
7 Hz - 70 kHz ± 0.5 dB

S/N (network A)

PHONO: 80 dB
TUNER, CD, AUX, TAPE1/DAT, TAPE2/MD: 105 dB

Output voltage / impedance

RECOU: 200 mV, 1 kilohm
PHONES: 5 mW (at 8 ohms)

Speakers impedance

4 - 16 ohms

Damping factor

80 (8 ohms, 1 kHz)

General

System

Power amplifier with all stages directly coupled
Preamplifier: Low-noise, equalizer amplifier

Power requirements

230 V AC, 50/60 Hz

Power consumption

TA-FE520R: 190 W
TA-FE320R: 160 W

Dimensions (approx.) (w/h/d)

430 × 130 × 310 mm
incl. projecting parts and controls

Mass (approx.)

TA-FE520R: 6.5 kg
TA-FE320R: 5.5 kg

Supplied accessories

Remote commander (remote) RM-S325 (1)
Sony batteries R6 (size-AA) (2)

Design and specifications are subject to change without notice.

INTEGRATED STEREO AMPLIFIER



SONY®

TABLE OF CONTENTS

1. GENERAL	
Location of Controls	3
2. DISASSEMBLY	4
3. DIAGRAMS	
3-1. Notes for Printed Wiring Boards and Schematic Diagrams	6
3-2. Printed Wiring Board – MAIN Section –	7
3-3. Schematic Diagram – MAIN Section –	9
3-4. Printed Wiring Boards – PANEL Section –	11
3-5. Schematic Diagram – PANEL Section –	13
3-6. Printed Wiring Boards – POWER Section –	15
3-7. Schematic Diagram – POWER Section –	16
3-8. IC Pin Function Description	18
4. EXPLODED VIEWS	19
5. ELECTRICAL PARTS LIST	21

SAFETY-RELATED COMPONENT WARNING!!

COMPONENTS IDENTIFIED BY MARK \triangle OR DOTTED LINE WITH MARK \triangle ON THE SCHEMATIC DIAGRAMS AND IN THE PARTS LIST ARE CRITICAL TO SAFE OPERATION. REPLACE THESE COMPONENTS WITH SONY PARTS WHOSE PART NUMBERS APPEAR AS SHOWN IN THIS MANUAL OR IN SUPPLEMENTS PUBLISHED BY SONY.

SECTION 1 GENERAL

This section is extracted from instruction manual.

LOCATION OF CONTROLS Front Panel

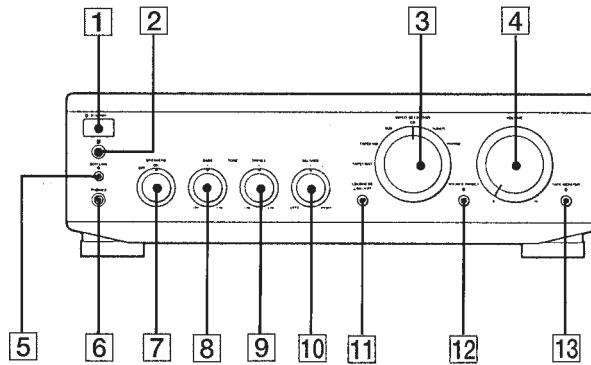

- 1 I/⏻ (POWER) button
- 2 Remote control sensor
- 3 INPUT SELECTOR switch
- 4 VOLUME control
- 5 EON LINK button (TA-FE520R only)
- 6 PHONES jack
- 7 SPEAKERS switch
- 8 BASS control
- 9 TREBLE control
- 10 BALANCE control
- 11 LOUDNESS button
- 12 SOURCE DIRECT button
- 13 TAPE MONITOR button (TA-FE520R only)

Rear Panel

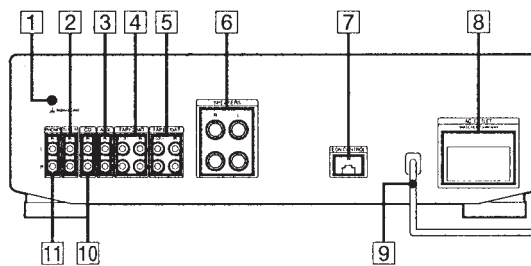

- 1 ⚡ (SIGNAL GND)
- 2 TUNER
- 3 AUX
- 4 TAPE2/MD
- 5 TAPE1/DAT
- 6 SPEAKERS
- 7 EON CONTROL IN (TA-FE520R only)
- 8 AC OUTLET (unavailable on the TA-FE320R (U.K. model))
- 9 Mains lead
- 10 CD
- 11 PHONO

SECTION 2 DISASSEMBLY

Note: Follow the disassembly procedure in the numerical order given.

FRONT PANEL SECTION

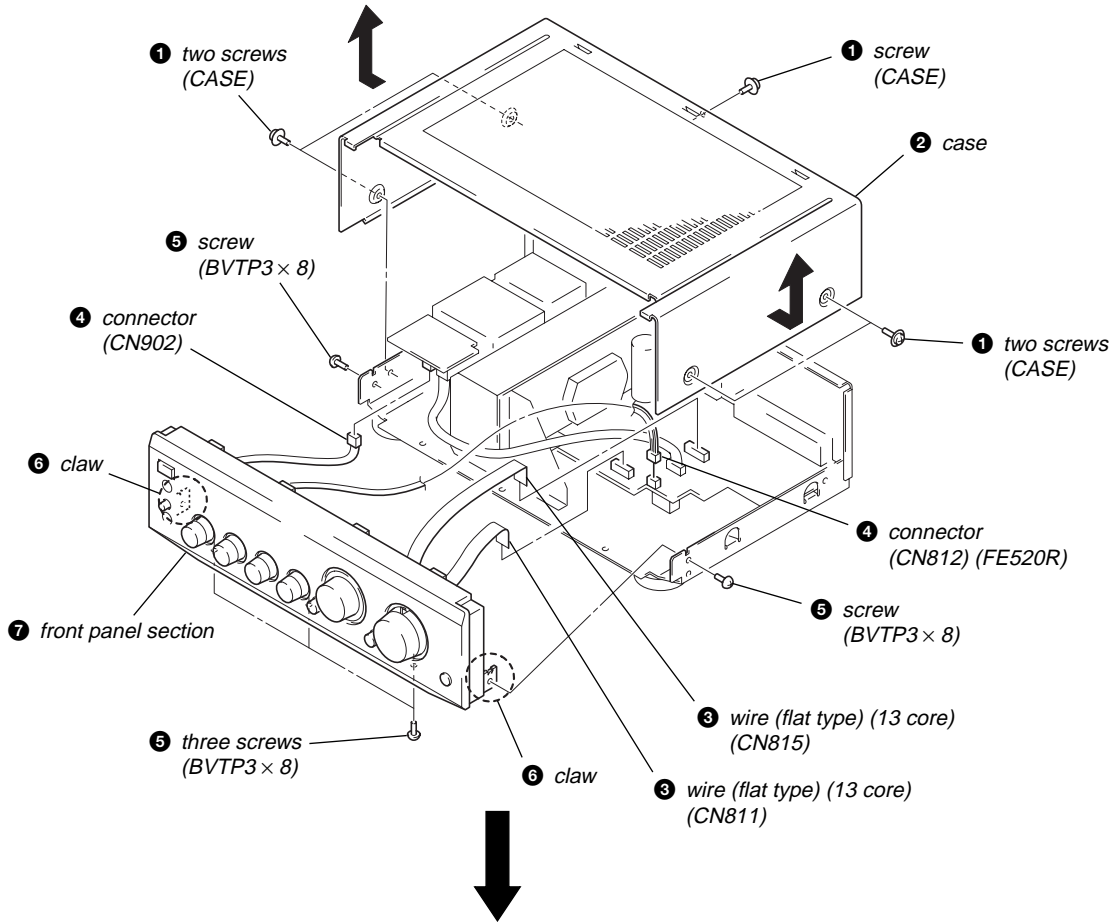

MAIN BOARD

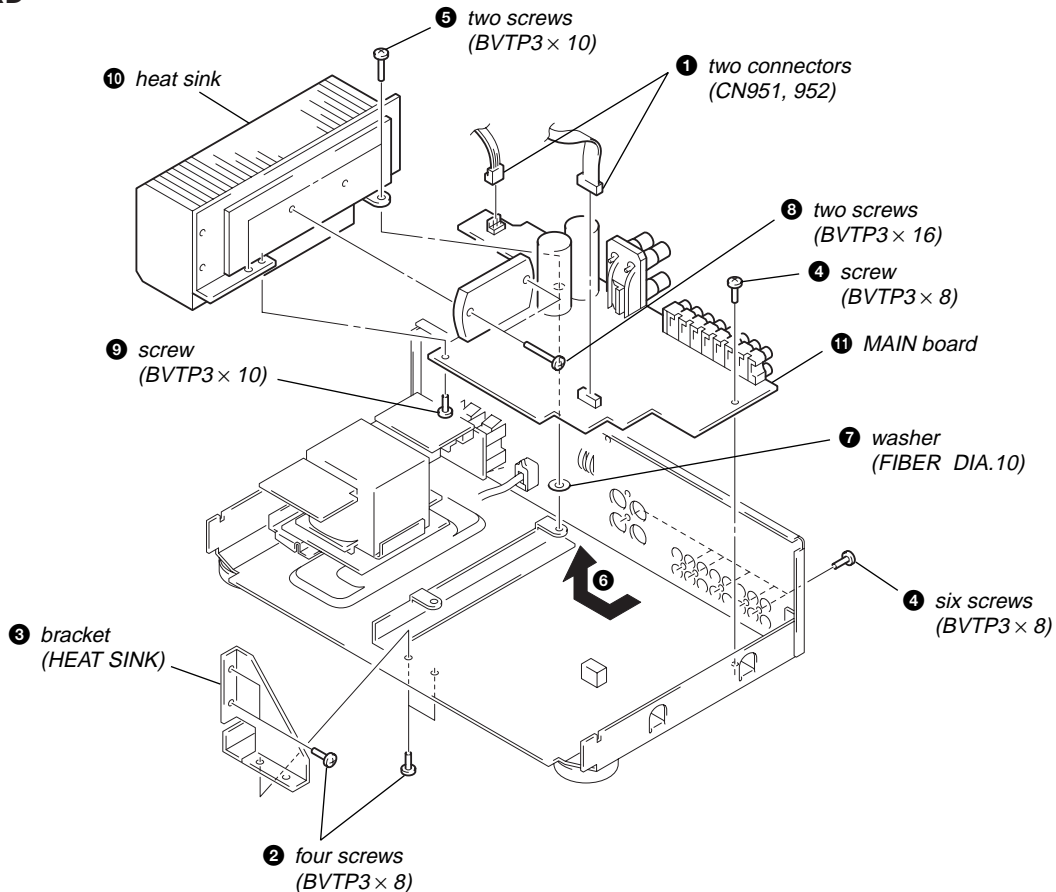

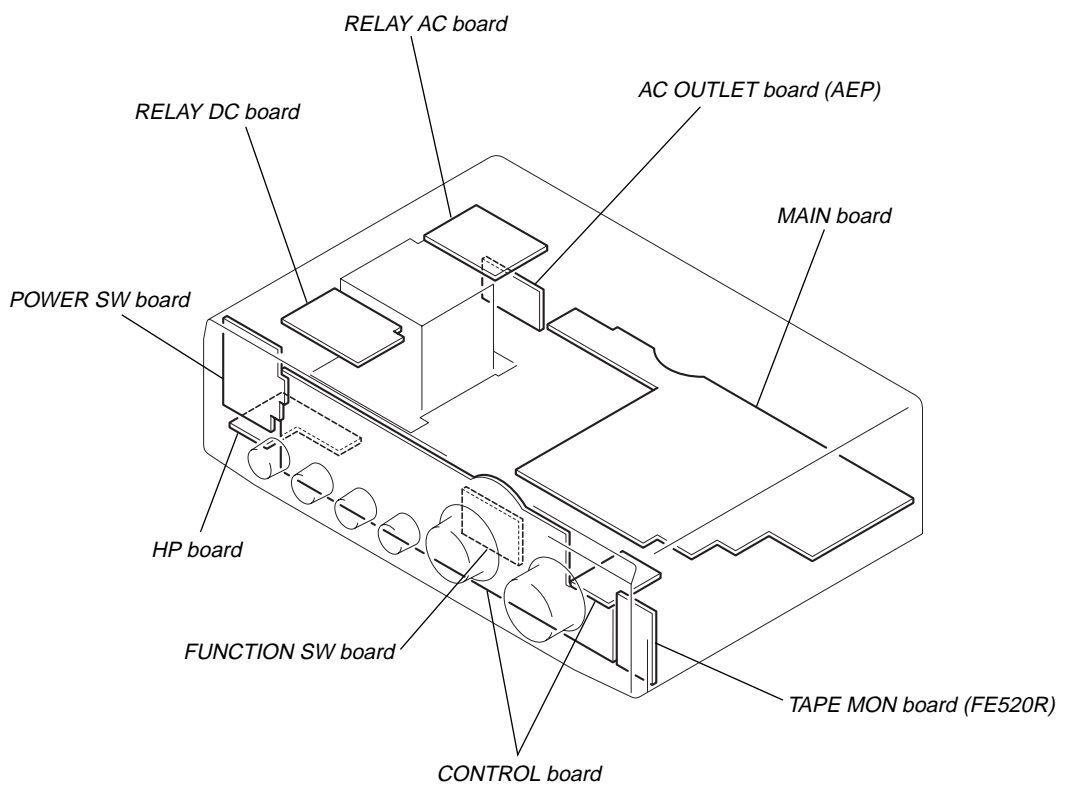

SECTION 3 DIAGRAMS

• Circuit Boards Location











3-1. NOTE FOR PRINTED WIRING BOARDS AND SCHEMATIC DIAGRAMS



Note on Schematic Diagram:

- All capacitors are in μF unless otherwise noted. pF : $\mu\mu\text{F}$ 50 WV or less are not indicated except for electrolytics and tantalums.
- All resistors are in Ω and $1/4\text{ W}$ or less unless otherwise specified.
- \triangle : internal component.
-  : nonflammable resistor.
-  : fusible resistor.
-  : panel designation.

Note: The components identified by mark \triangle or dotted line with mark \triangle are critical for safety.
Replace only with part number specified.

-  : B+ Line.
-  : B- Line.
- Voltages are dc with respect to ground under no-signal conditions.
no mark : TUNER
- Voltages are taken with a VOM (Input impedance 10 M Ω).
Voltage variations may be noted due to normal production tolerances.
- Signal path.
 -  : TUNER
 -  : PB (TAPE1/DAT)
 -  : REC
 -  : PB (TAPE2/MD)
 -  : CD
 -  : PHONO

Note on Printed Wiring Boards:

-  : parts extracted from the component side.
- \triangle : internal component.
-  : Pattern from the side which enables seeing.
- Indication of diode

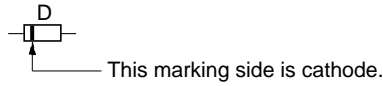

3-3. SCHEMATIC DIAGRAM – MAIN Section – • See page 17 for IC Block Diagrams.

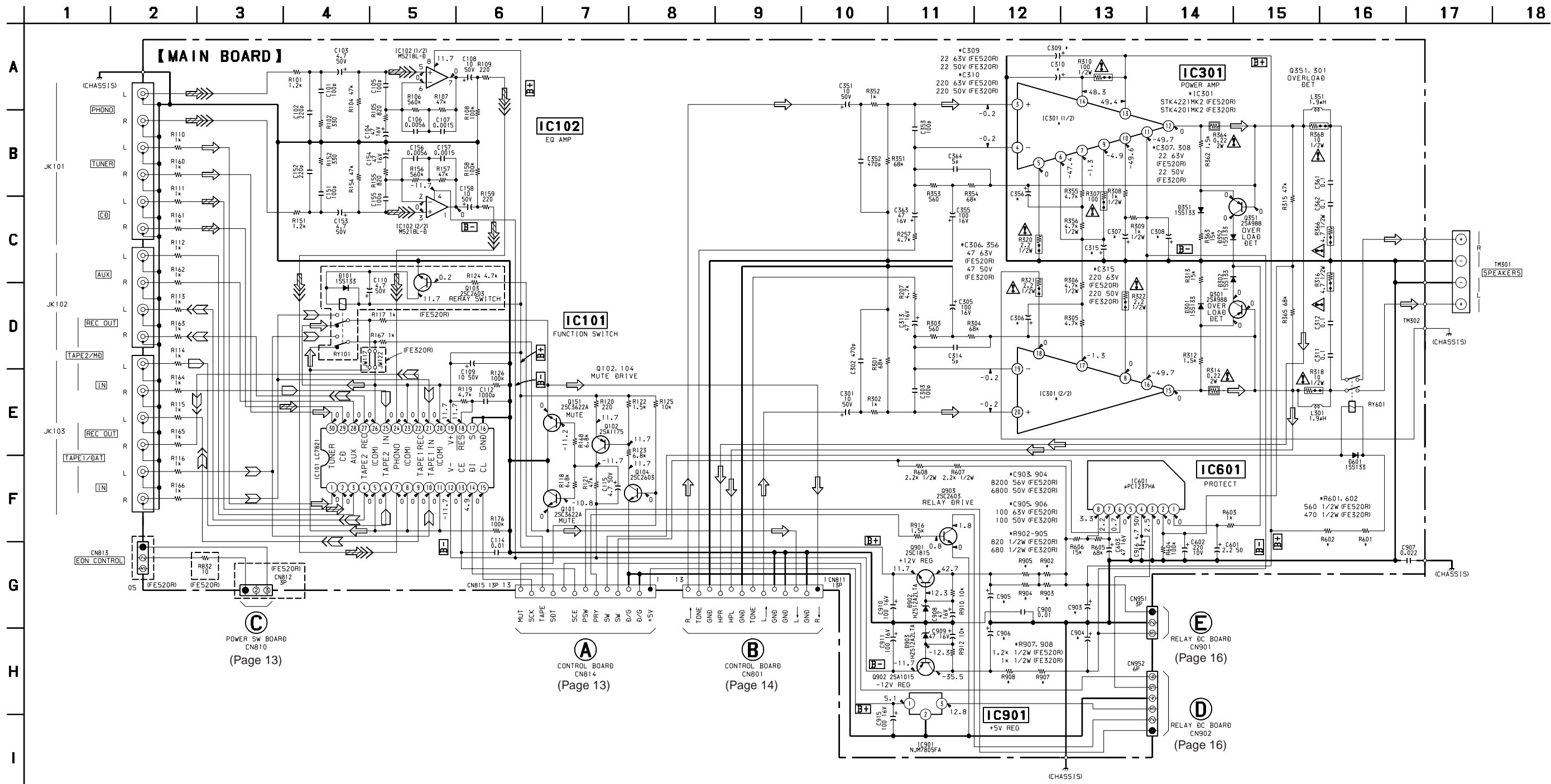

3-5. SCHEMATIC DIAGRAM – PANEL Section – • See page 17 for IC Block Diagrams.

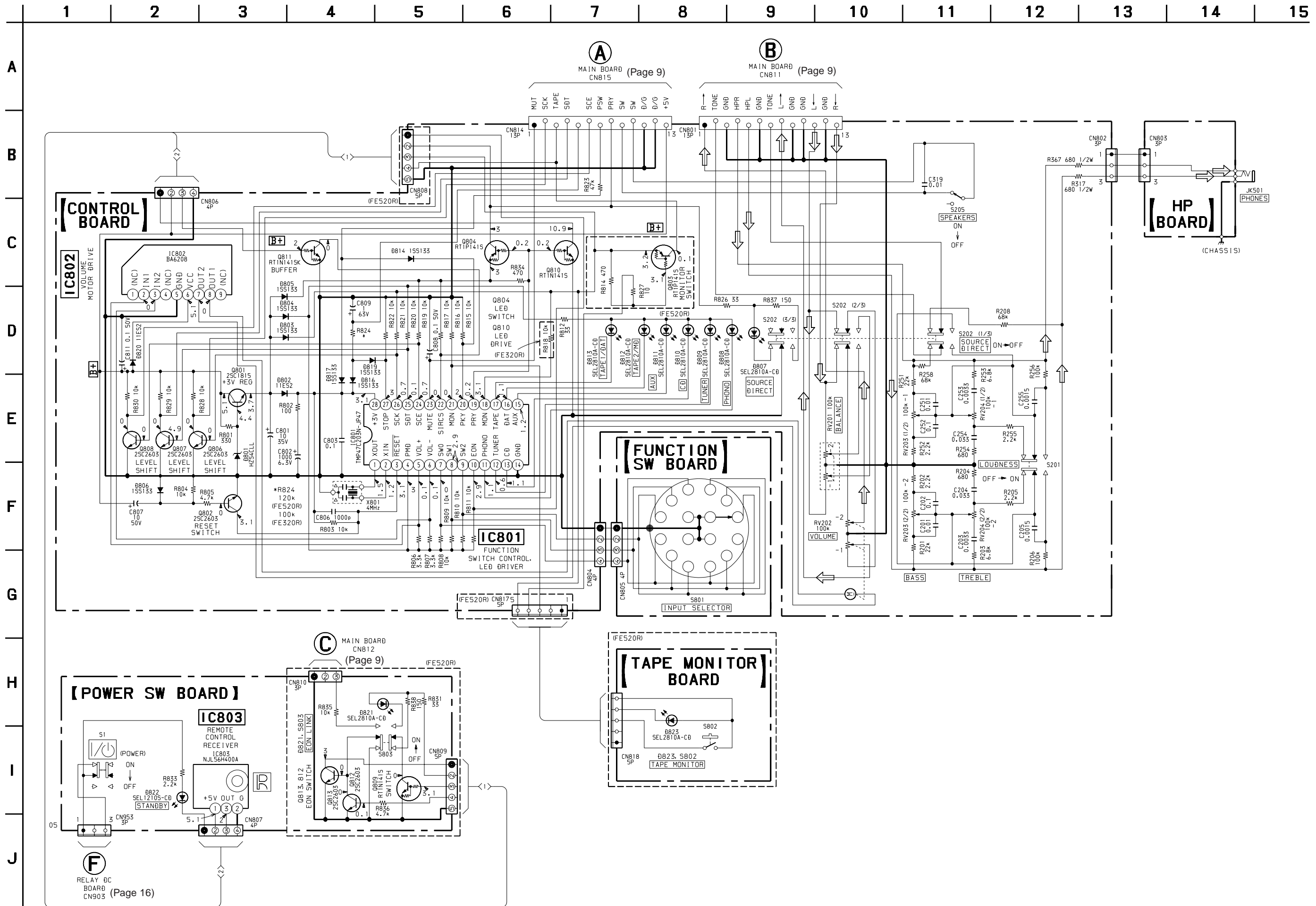

3-6. PRINTED WIRING BOARDS – POWER Section –

• See page 5 for Circuit Boards Location.

• **Semiconductor
Location**

Ref. No.	Location
D901	B-2
D904	A-1
D905	B-1
D906	B-1
D907	B-1
D908	B-1
D909	B-1
D910	A-2
D911	E-2

3-7. SCHEMATIC DIAGRAM – POWER Section –

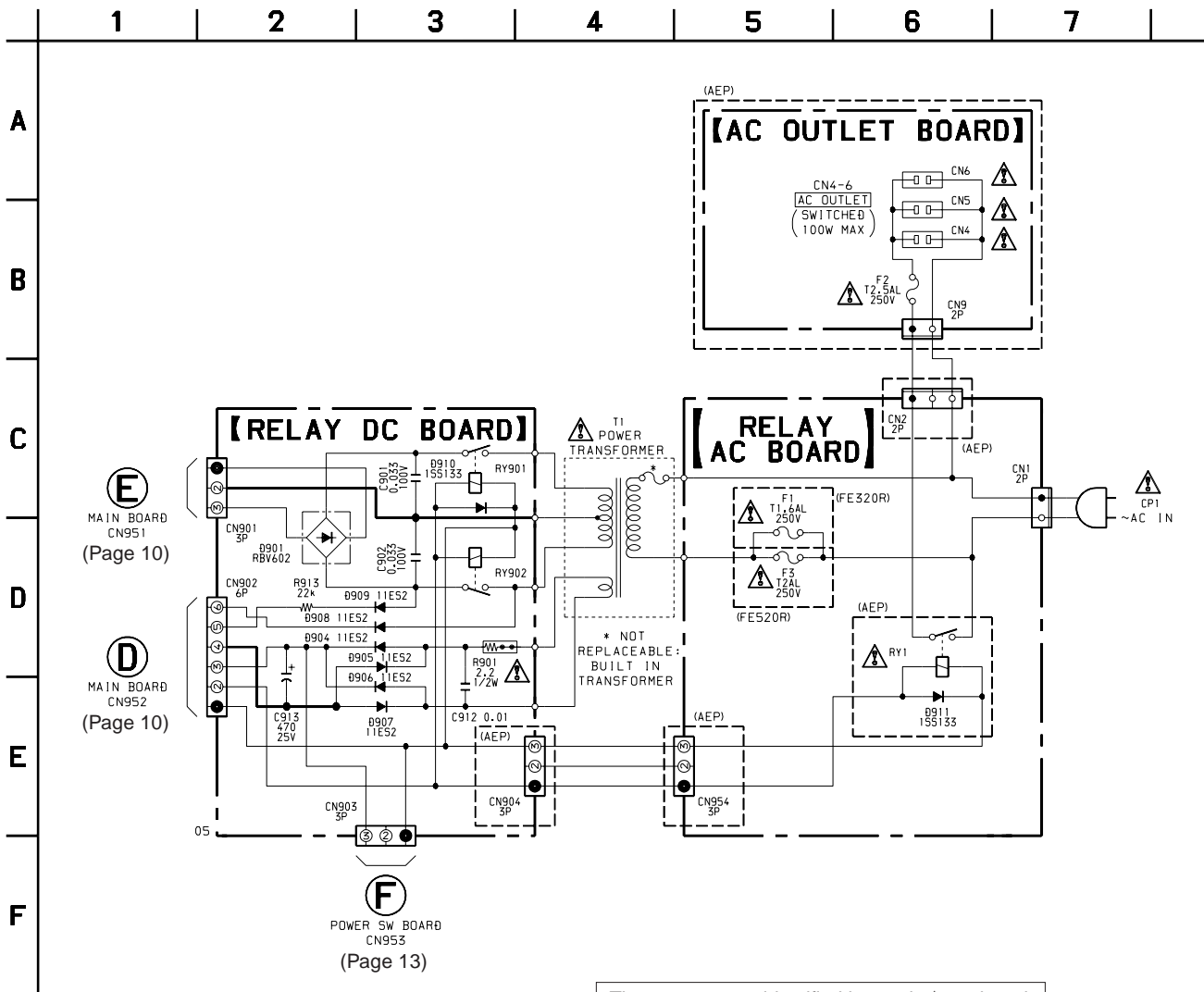

The components identified by mark Δ or dotted line with mark Δ are critical for safety. Replace only with part number specified.

• IC Block Diagrams

IC101 LC7821 (MAIN BOARD)

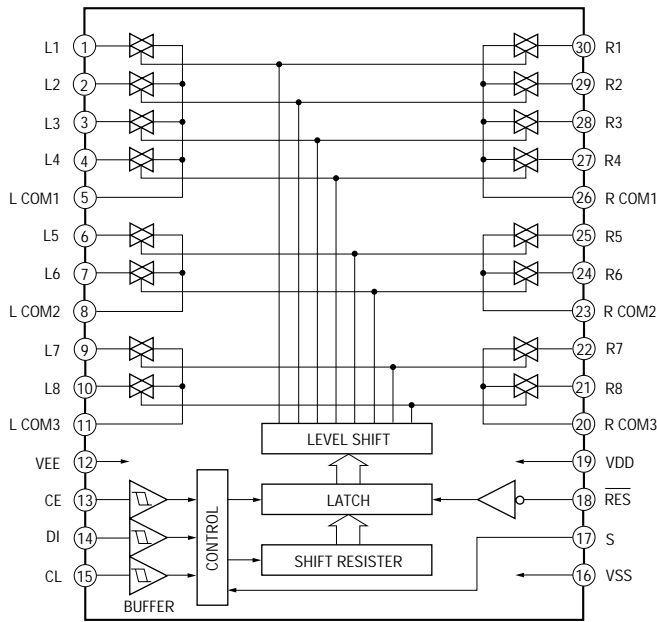

IC601 μPC1237HA (MAIN BOARD)

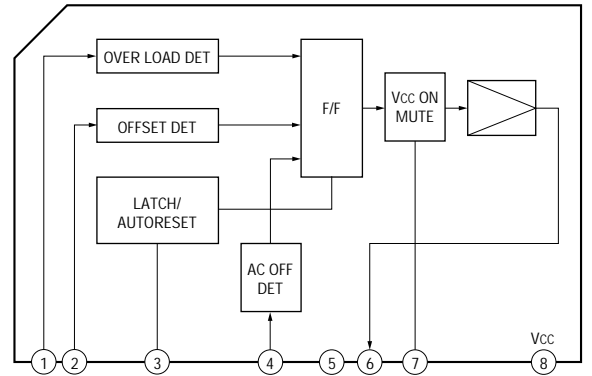

IC802 BA6208 (CONTROL BOARD)

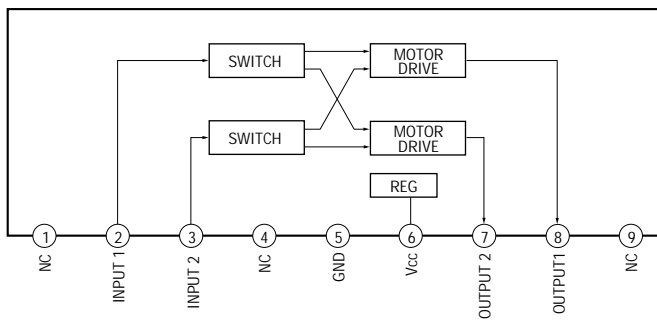

3-8. IC PIN FUNCTION DESCRIPTION

• CONTROL BOARD IC801 TMP47C103N-JP47 (FUNCTION SWITCH CONTROL, LED DRIVER)

Pin No.	Pin Name	I/O	Function
1	XOUT	O	Main system clock output terminal (4 MHz)
2	XIN	I	Main system clock input terminal (4 MHz)
3	$\overline{\text{RESET}}$	I	System reset signal input terminal "L": reset For several hundreds msec. after the power supply rises, "L" is input, then it changes to "H"
4	PMD	I	Mode select input terminal Fixed at "H" in this set
5	VOL+	O	Motor drive signal output to the volume motor drive (IC802) (volume up direction)
6	VOL-	O	Motor drive signal output to the volume motor drive (IC802) (volume down direction)
7	SW0	I	Rotary switch input of the INPUT SELECTOR (S801)
8	SW1	I	
9	SW2	I	
10	EON	I	Detection signal input of the enhanced other networks (EON) Used for the TA-FE520R only
11	PHONO	O	LED drive signal output of the PHONO LED (D808) "L": LED on
12	TUNER	O	LED drive signal output of the TUNER LED (D809) "L": LED on
13	CD	O	LED drive signal output of the CD LED (D810) "L": LED on
14	GND	—	Ground terminal
15	AUX	O	LED drive signal output of the AUX LED (D811) "L": LED on
16	DAT	O	LED drive signal output of the TAPE2/MD LED (D812) "L": LED on
17	TAPE	O	LED drive signal output of the TAPE1/DAT LED (D813) "L": LED on
18	MON	O	Tape monitor on/off control signal output terminal "L": tape monitor on Used for the TA-FE520R only
19	PRY	O	AC on/off relay drive signal output terminal "L": power on, "H": standby mode
20	PKY	I	Power switch (S1; I/⏻) input terminal "H": power on
21	MON	I	Tape monitor switch (S802) input terminal When pressing the key: "H"
22	SIRCS	I	Sires signal input from the remote control receiver (IC803)
23	MUTE	O	Audio line muting on/off control signal output terminal "H": muting on
24	SCE	O	Chip enable signal output to the function switch (IC101)
25	SDT	O	Serial data output to the function switch (IC101)
26	SCK	O	Serial data transfer clock signal output to the function switch (IC101)
27	STOP	I	Detection signal input of the AC input
28	+3V	—	Power supply terminal (+3V)

SECTION 4 EXPLODED VIEWS

NOTE:

- -XX and -X mean standardized parts, so they may have some difference from the original one.
- Color Indication of Appearance Parts
Example:
KNOB, BALANCE (WHITE) . . . (RED)
 ↑ ↑
 Parts Color Cabinet's Color

- Items marked "*" are not stocked since they are seldom required for routine service. Some delay should be anticipated when ordering these items.
- The mechanical parts with no reference number in the exploded views are not supplied.
- Hardware (# mark) list and accessories and packing materials are given in the last of the electrical parts list.

The components identified by mark Δ or dotted line with mark Δ are critical for safety. Replace only with part number specified.

(1) FRONT PANEL SECTION

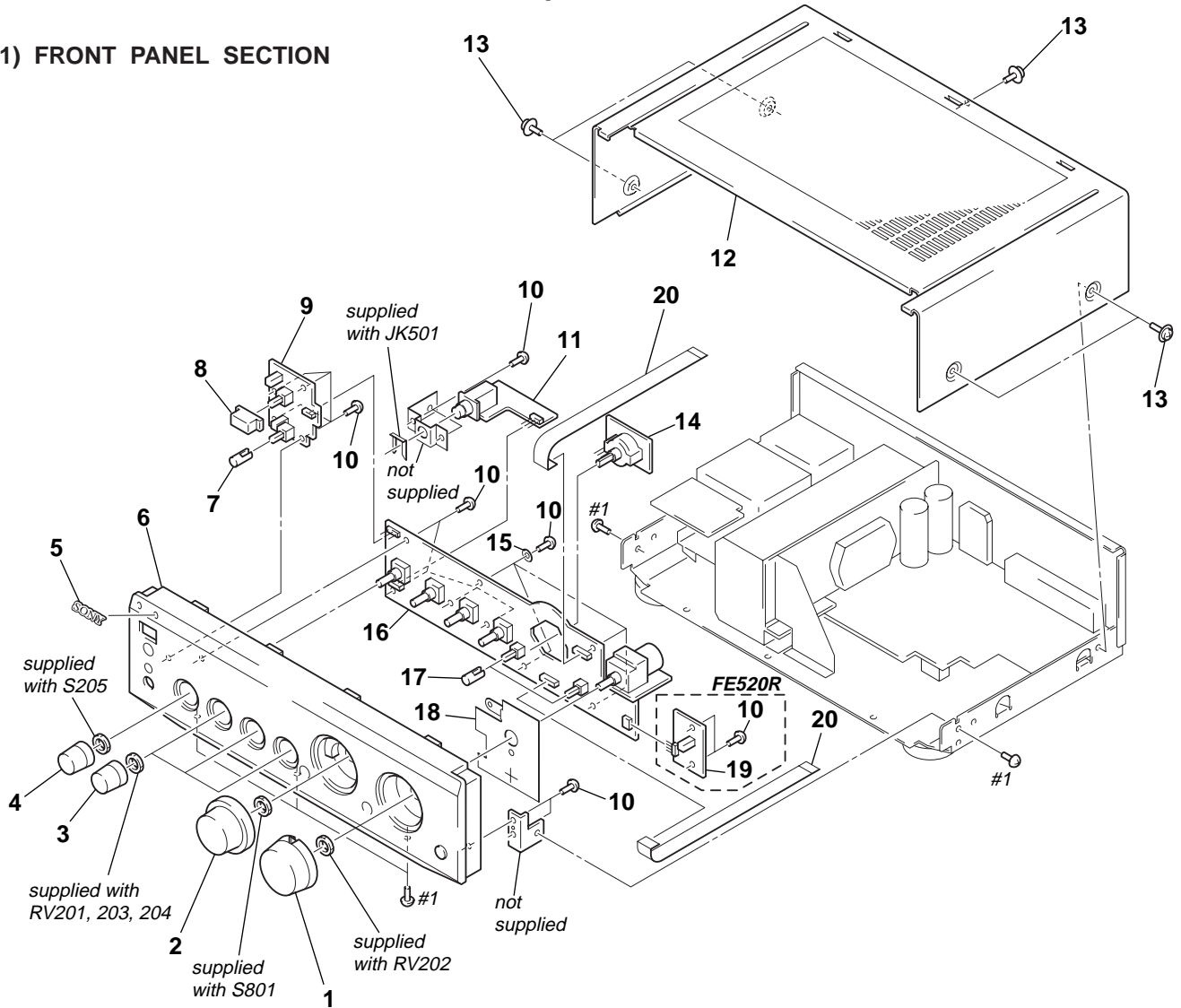

Ref. No.	Part No.	Description	Remark	Ref. No.	Part No.	Description	Remark
1	X-4950-306-1	KNOB ASSY, VOLUME (BLACK)		*	9	1-670-966-11	POWER SW BOARD
1	X-4950-307-1	KNOB ASSY, VOLUME (SILVER)			10	4-951-620-01	SCREW (2.6X8), +BVTP
2	4-211-947-01	KNOB (FUNCTION) (BLACK)		*	11	1-670-967-11	HP BOARD
2	4-211-947-11	KNOB (FUNCTION) (SILVER)		*	12	4-211-940-21	CASE (BLACK)
3	4-211-945-01	KNOB (BALANCE) (BLACK)		*	12	4-211-940-31	CASE (SILVER)
3	4-211-945-11	KNOB (BALANCE) (SILVER)			13	3-704-366-01	SCREW (CASE) (M3X8) (BLACK)
4	4-211-950-01	KNOB (SPEAKER) (BLACK)			13	3-704-366-71	SCREW (CASE) (M3X8) (SILVER)
4	4-211-950-11	KNOB (SPEAKER) (SILVER)		*	14	1-670-968-11	FUNCTION SW BOARD
5	4-996-698-41	EMBLEM, SONY			15	4-211-951-01	WASHER (FIBER DIA. 8)
6	X-4950-304-1	PANEL ASSY, FRONT (FE520R: BLACK)		*	16	A-4417-046-A	CONTROL BOARD, COMPLETE (FE520R)
6	X-4950-305-1	PANEL ASSY, FRONT (FE520R: SILVER)		*	16	A-4417-056-A	CONTROL BOARD, COMPLETE (FE320R)
6	X-4950-308-1	PANEL ASSY, FRONT (FE320R)			17	4-211-948-01	BUTTON (LOUDNESS) (BLACK)
7	4-211-946-01	BUTTON (LINK) (BLACK)			17	4-211-948-11	BUTTON (LOUDNESS) (SILVER)
7	4-211-946-11	BUTTON (LINK) (SILVER)		*	18	4-211-953-01	SHIELD (VOLUME)
8	4-211-949-01	BUTTON, POWER (BLACK)		*	19	1-670-969-11	TAPE MON BOARD (FE520R)
8	4-211-949-11	BUTTON, POWER (SILVER)		*	20	1-769-983-11	WIRE (FLAT TYPE) (13 CORE)

(2) CHASSIS SECTION

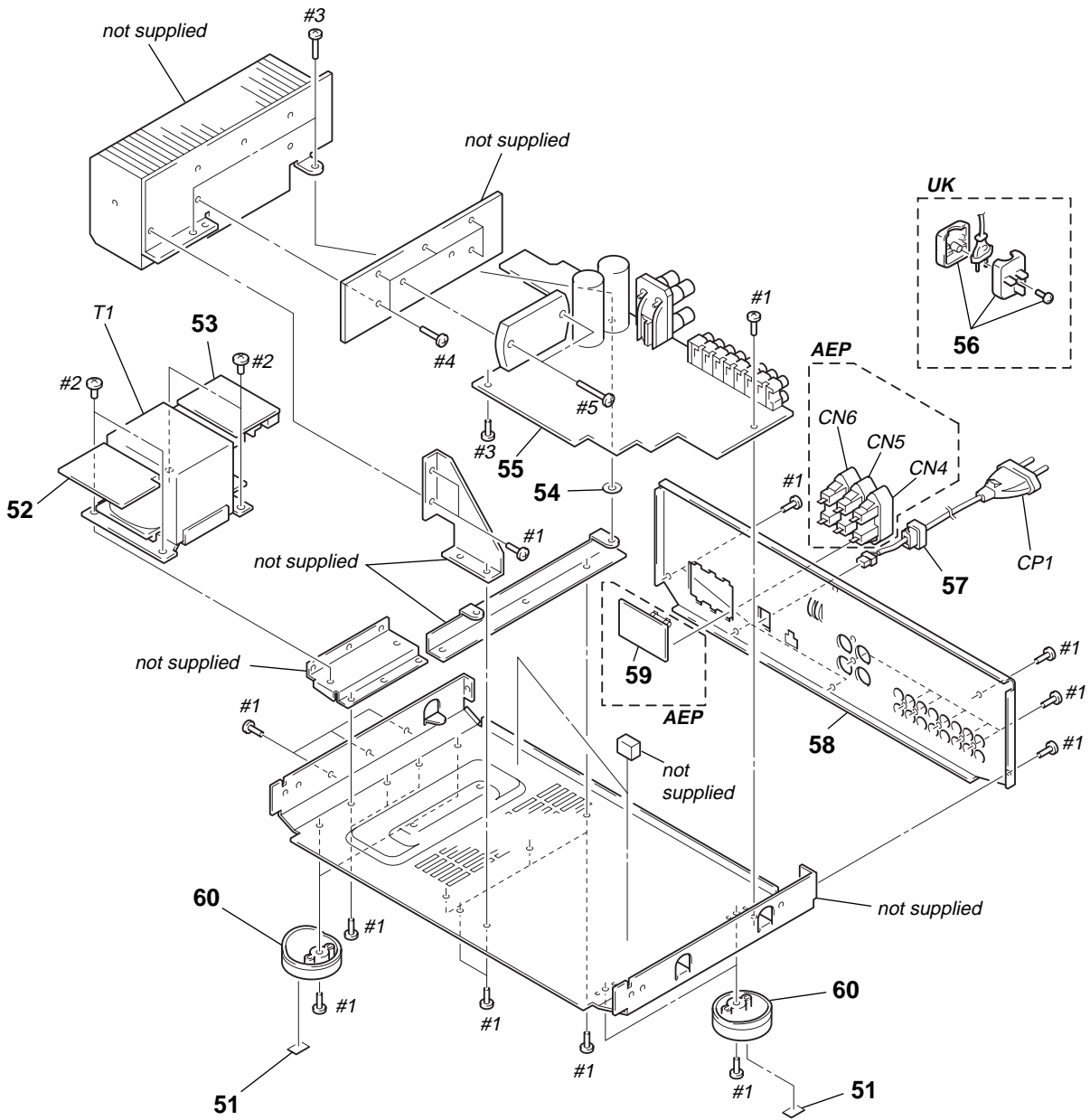

The components identified by mark Δ or dotted line with mark Δ are critical for safety.
Replace only with part number specified.

Ref. No.	Part No.	Description	Remark	Ref. No.	Part No.	Description	Remark
* 51	4-978-398-21	CUSHION		* 58	4-211-938-21	PANEL, REAR (FE320R: UK)	
* 52	1-670-972-11	RELAY DC BOARD		* 59	1-670-970-11	AC OUTLET BOARD (AEP)	
* 53	1-670-971-11	RELAY AC BOARD		60	4-977-591-01	FOOT (F50150S) (BLACK)	
54	4-211-952-01	WASHER (FIBER DIA. 10)		60	4-977-591-31	FOOT (F50150S) (SILVER)	
* 55	A-4417-045-A	MAIN BOARD, COMPLETE (FE520R)		CN4	1-526-794-11	OUTLET, AC (AEP)	
* 55	A-4417-055-A	MAIN BOARD, COMPLETE (FE320R)		CN5	1-526-794-11	OUTLET, AC (AEP)	
Δ 56	1-770-019-11	ADAPTOR, CONVERSION PLUG 3P (UK)		CN6	1-526-794-11	OUTLET, AC (AEP)	
* 57	3-703-244-00	BUSHING (2104), CORD		Δ CP1	1-575-651-21	CORD, POWER	
* 58	4-211-938-01	PANEL, REAR (FE520R)		Δ T1	1-431-802-11	TRANSFORMER, POWER (FE520R)	
* 58	4-211-938-11	PANEL, REAR (FE320R: AEP)		Δ T1	1-431-803-11	TRANSFORMER, POWER (FE320R)	

SECTION 5 ELECTRICAL PARTS LIST

AC OUTLET

CONTROL

NOTE:

- Due to standardization, replacements in the parts list may be different from the parts specified in the diagrams or the components used on the set.
- -XX and -X mean standardized parts, so they may have some difference from the original one.
- RESISTORS
All resistors are in ohms.
METAL: Metal-film resistor.
METAL OXIDE: Metal oxide-film resistor.
F: nonflammable

- Items marked “*” are not stocked since they are seldom required for routine service. Some delay should be anticipated when ordering these items.
- SEMICONDUCTORS
In each case, u: μ , for example:
uA. . : μ A. . uPA. . : μ PA. .
uPB. . : μ PB. . uPC. . : μ PC. .
uPD. . : μ PD. .
- CAPACITORS
uF: μ F
- COILS
uH: μ H

The components identified by mark Δ or dotted line with mark Δ are critical for safety. Replace only with part number specified.

When indicating parts by reference number, please include the board.

Ref. No.	Part No.	Description	Remark	Ref. No.	Part No.	Description	Remark
*	1-670-970-11	AC OUTLET BOARD (AEP) *****		CN802	1-770-396-11	HOUSING, CONNECTOR (PC BOARD) 3P	
	1-533-293-11	FUSE HOLDER		CN808	1-564-707-11	PIN, CONNECTOR (SMALL TYPE) 5P (FE520R)	
		< CONNECTOR >		CN804	1-770-397-11	HOUSING, CONNECTOR (PC BOARD) 4P	
Δ CN4	1-526-794-11	OUTLET, AC		* CN814	1-568-832-11	SOCKET, CONNECTOR 13P	
Δ CN5	1-526-794-11	OUTLET, AC				< DIODE >	
Δ CN6	1-526-794-11	OUTLET, AC					
		< FUSE >		D801	8-719-985-59	DIODE HZS4CLL-TA	
Δ F2	1-532-464-51	FUSE (T2.5AL/250V)		D802	8-719-200-82	DIODE 11ES2	
		*****		D803	8-719-911-19	DIODE 1SS119	
*	A-4417-046-A	CONTROL BOARD, COMPLETE (FE520R)		D804	8-719-911-19	DIODE 1SS119	
*	A-4417-056-A	CONTROL BOARD, COMPLETE (FE320R) *****		D805	8-719-911-19	DIODE 1SS119	
*	4-211-967-01	HOLDER (LED)		D806	8-719-911-19	DIODE 1SS119	
		< CAPACITOR >		D807	8-719-301-49	LED SEL2810A (SOURCE DILECT)	
C201	1-136-153-00	FILM	0.01uF 5% 50V	D808	8-719-301-49	LED SEL2810A (PHONO)	
C202	1-136-165-00	FILM	0.1uF 5% 50V	D809	8-719-301-49	LED SEL2810A (TUNER)	
C203	1-130-477-00	MYLAR	0.0033uF 5% 50V	D810	8-719-301-49	LED SEL2810A (CD)	
C204	1-130-489-11	MYLAR	0.033uF 5% 50V			< IC >	
C205	1-130-473-00	MYLAR	0.0015uF 5% 50V	IC801	8-759-392-41	IC TMP47C103N-JP47	
C251	1-136-153-00	FILM	0.01uF 5% 50V	IC802	8-759-962-08	IC BA6208	
C252	1-136-165-00	FILM	0.1uF 5% 50V			< TRANSISTOR >	
C253	1-130-477-00	MYLAR	0.0033uF 5% 50V	Q801	8-729-119-78	TRANSISTOR 2SC403SP-51	
C254	1-130-489-11	MYLAR	0.033uF 5% 50V	Q802	8-729-620-05	TRANSISTOR 2SC2603-EF	
C255	1-130-473-00	MYLAR	0.0015uF 5% 50V	Q803	8-729-029-20	TRANSISTOR RT1P141S-TP (FE520R)	
C319	1-136-153-00	FILM	0.01uF 5% 50V	Q804	8-729-029-20	TRANSISTOR RT1P141S-TP	
C801	1-126-964-11	ELECT	10uF 20% 50V	Q806	8-729-620-05	TRANSISTOR 2SC2603-EF	
C802	1-126-916-11	ELECT	1000uF 20% 6.3V				
C803	1-136-165-00	FILM	0.1uF 5% 50V	Q807	8-729-620-05	TRANSISTOR 2SC2603-EF	
C806	1-164-085-11	CERAMIC	0.001uF 10% 50V	Q808	8-729-620-05	TRANSISTOR 2SC2603-EF	
C807	1-126-964-11	ELECT	10uF 20% 50V	Q810	8-729-029-66	TRANSISTOR DTC114ESA	
C808	1-126-956-11	ELECT	0.1uF 20% 50V	Q811	8-729-029-66	TRANSISTOR DTC114ESA	
C809	1-128-578-11	ELECT	1uF 20% 100V				
C811	1-136-165-00	FILM	0.1uF 5% 50V				
		< CONNECTOR >					
* CN801	1-568-832-11	SOCKET, CONNECTOR 13P					

CONTROL	FUNCTION SW	HP	MAIN
----------------	--------------------	-----------	-------------

Ref. No.	Part No.	Description		Remark	Ref. No.	Part No.	Description		Remark		
< RESISTOR >					< SWITCH >						
R201	1-247-863-11	CARBON	22K	5%	1/4W	S201	1-571-112-21	SWITCH, PUSH (1 KEY) (LOUDNESS)			
R202	1-247-839-11	CARBON	2.2K	5%	1/4W	S202	1-571-828-11	SWITCH, PUSH (1 KEY) (SOURCE DIRECT)			
R203	1-249-427-11	CARBON	6.8K	5%	1/4W	S205	1-771-369-11	SWITCH, ROTARY (SPEAKERS)			
R204	1-247-827-11	CARBON	680	5%	1/4W	< VIBRATOR >					
R205	1-247-839-11	CARBON	2.2K	5%	1/4W	X801	1-577-358-21	VIBRATOR, CERAMIC (4MHZ)			
R206	1-249-469-11	CARBON	100K	5%	1/4W	*****					
R208	1-249-439-11	CARBON	68K	5%	1/4W	*	1-670-968-11	FUNCTION SW BOARD			
R251	1-247-863-11	CARBON	22K	5%	1/4W	*****					
R252	1-247-839-11	CARBON	2.2K	5%	1/4W	< SWITCH >					
R253	1-249-427-11	CARBON	6.8K	5%	1/4W	S801	1-692-974-11	SWITCH, ROTARY (INPUT SELECTOR)			
R254	1-247-827-11	CARBON	680	5%	1/4W	*****					
R255	1-247-839-11	CARBON	2.2K	5%	1/4W	*	1-670-967-11	HP BOARD			
R256	1-249-469-11	CARBON	100K	5%	1/4W	*****					
R258	1-249-439-11	CARBON	68K	5%	1/4W	< JACK >					
R317	1-247-750-11	CARBON	680	5%	1/2W	JK501	1-785-094-11	JACK (LARGE TYPE) (PHONES)			
R367	1-247-750-11	CARBON	680	5%	1/2W	*****					
R801	1-249-411-11	CARBON	330	5%	1/4W	*	A-4417-045-A	MAIN BOARD, COMPLETE (FE520R)			
R802	1-247-807-11	CARBON	100	5%	1/4W	*	A-4417-055-A	MAIN BOARD, COMPLETE (FE320R)			
R803	1-247-855-11	CARBON	10K	5%	1/4W	*****					
R804	1-247-855-11	CARBON	10K	5%	1/4W	< CAPACITOR >					
R805	1-247-847-11	CARBON	4.7K	5%	1/4W	C101	1-164-073-11	CERAMIC	100PF	10%	50V
R806	1-247-843-11	CARBON	3.3K	5%	1/4W	C102	1-164-077-11	CERAMIC	220PF	10%	50V
R807	1-247-843-11	CARBON	3.3K	5%	1/4W	C103	1-126-963-11	ELECT	4.7uF	20%	50V
R808	1-247-855-11	CARBON	10K	5%	1/4W	C104	1-126-967-11	ELECT	47uF	20%	16V
R809	1-247-855-11	CARBON	10K	5%	1/4W	C105	1-164-073-11	CERAMIC	100PF	10%	50V
R810	1-247-855-11	CARBON	10K	5%	1/4W	C106	1-130-480-00	MYLAR	0.0056uF	5%	50V
R811	1-247-855-11	CARBON	10K	5%	1/4W	C107	1-130-473-00	MYLAR	0.0015uF	5%	50V
R812	1-249-399-11	CARBON	33	5%	1/4W	C108	1-126-964-11	ELECT	10uF	20%	50V
R814	1-249-413-11	CARBON	470	5%	1/4W	C109	1-126-964-11	ELECT	10uF	20%	50V
R815	1-247-855-11	CARBON	10K	5%	1/4W	C110	1-126-963-11	ELECT	4.7uF	20%	50V
R816	1-247-855-11	CARBON	10K	5%	1/4W	(FE520R)					
R817	1-247-855-11	CARBON	10K	5%	1/4W	C112	1-164-085-11	CERAMIC	0.001uF	10%	50V
R818	1-247-855-11	CARBON	10K	5%	1/4W	C114	1-164-096-11	CERAMIC	0.01uF		50V
R820	1-247-855-11	CARBON	10K	5%	1/4W	C115	1-126-963-11	ELECT	4.7uF	20%	50V
R821	1-247-855-11	CARBON	10K	5%	1/4W	C151	1-164-073-11	CERAMIC	100PF	10%	50V
R822	1-247-855-11	CARBON	10K	5%	1/4W	C152	1-164-077-11	CERAMIC	220PF	10%	50V
R823	1-247-871-11	CARBON	47K	5%	1/4W	(FE320R)					
R824	1-247-879-11	CARBON	100K	5%	1/4W	C153	1-126-963-11	ELECT	4.7uF	20%	50V
R824	1-247-881-11	CARBON	120K	5%	1/4W	C154	1-126-967-11	ELECT	47uF	20%	16V
R826	1-249-399-11	CARBON	33	5%	1/4W	C155	1-164-073-11	CERAMIC	100PF	10%	50V
R827	1-249-393-11	CARBON	10	5%	1/4W	C156	1-130-480-00	MYLAR	0.0056uF	5%	50V
R829	1-247-855-11	CARBON	10K	5%	1/4W	C157	1-130-473-00	MYLAR	0.0015uF	5%	50V
R830	1-247-855-11	CARBON	10K	5%	1/4W	(FE520R)					
R834	1-249-413-11	CARBON	470	5%	1/4W	C158	1-126-964-11	ELECT	10uF	20%	50V
R837	1-249-407-11	CARBON	150	5%	1/4W	C301	1-126-964-11	ELECT	10uF	20%	50V
< VARIABLE RESISTOR >					C302	1-164-081-11	CERAMIC	470PF	10%	50V	
RV201	1-223-396-11	RES, VAR, CARBON 100K/100K (BALANCE)			C303	1-164-073-11	CERAMIC	100PF	10%	50V	
RV202	1-241-426-11	RES, VAR, CARBON 100KX2 (VOLUME)			C305	1-126-933-11	ELECT	100uF	20%	16V	
RV203	1-223-397-11	RES, VAR, CARBON 100K/100K (BASS)			C306	1-126-967-11	ELECT	47uF	20%	50V	
RV204	1-223-397-11	RES, VAR, CARBON 100K/100K (TREBLE)			C306	1-128-552-11	ELECT	47uF	20%	63V	
					(FE520R)						

Ref. No.	Part No.	Description	Remark	Ref. No.	Part No.	Description	Remark
C307	1-126-965-11	ELECT	22uF 20% 50V (FE320R)	C911	1-126-933-11	ELECT	100uF 20% 16V
C307	1-128-551-11	ELECT	22uF 20% 63V (FE520R)	C915	1-126-933-11	ELECT	100uF 20% 16V
C308	1-126-965-11	ELECT	22uF 20% 50V (FE320R)	C916	1-126-963-11	ELECT	4.7uF 20% 50V
C308	1-128-551-11	ELECT	22uF 20% 63V (FE520R)	< CONNECTOR >			
C309	1-126-965-11	ELECT	22uF 20% 50V (FE320R)	* CN811	1-568-832-11	SOCKET, CONNECTOR 13P	
C309	1-128-551-11	ELECT	22uF 20% 63V (FE520R)	CN812	1-564-506-11	PLUG, CONNECTOR 3P (FE520R)	
C310	1-126-969-11	ELECT	220uF 20% 50V (FE320R)	CN813	1-566-212-11	PIN, CONNECTOR 3P (EON CONTROL)	(FE520R)
C310	1-128-553-11	ELECT	220uF 20% 63V (FE520R)	* CN815	1-568-832-11	SOCKET, CONNECTOR 13P	
C311	1-136-165-00	FILM	0.1uF 5% 50V	* CN951	1-564-104-00	PIN, CONNECTOR (B3P-VH) 3P	
C312	1-136-165-00	FILM	0.1uF 5% 50V	CN952	1-691-768-11	PLUG (MICRO CONNECTOR) 6P	
C313	1-126-967-11	ELECT	47uF 20% 16V	< DIODE >			
C314	1-164-014-11	CERAMIC	5PF 0.25PF 50V	D101	8-719-911-19	DIODE 1SS119 (FE520R)	
C315	1-126-969-11	ELECT	220uF 20% 50V (FE320R)	D301	8-719-911-19	DIODE 1SS119	
C315	1-128-553-11	ELECT	220uF 20% 63V (FE520R)	D302	8-719-911-19	DIODE 1SS119	
C351	1-126-964-11	ELECT	10uF 20% 50V (FE320R)	D351	8-719-911-19	DIODE 1SS119	
C352	1-164-081-11	CERAMIC	470PF 10% 50V	D352	8-719-911-19	DIODE 1SS119	
C353	1-164-073-11	CERAMIC	100PF 10% 50V	D601	8-719-911-19	DIODE 1SS119	
C355	1-126-933-11	ELECT	100uF 20% 16V	D902	8-719-986-25	DIODE HZS12A2LTA	
C356	1-126-967-11	ELECT	47uF 20% 50V (FE320R)	D903	8-719-986-25	DIODE HZS12A2LTA	
C356	1-128-552-11	ELECT	47uF 20% 63V (FE520R)	< IC >			
C361	1-136-165-00	FILM	0.1uF 5% 50V	IC101	8-759-805-13	IC LC7821	
C362	1-136-165-00	FILM	0.1uF 5% 50V	IC102	8-759-184-02	IC NJM2068L-D	
C363	1-126-967-11	ELECT	47uF 20% 16V	IC301	8-749-920-90	IC STK-4201MK2 (FE320R)	
C364	1-164-014-11	CERAMIC	5PF 0.25PF 50V	IC301	8-749-922-65	IC STK-4221MK2 (FE520R)	
C601	1-126-961-11	ELECT	2.2uF 20% 50V	IC601	8-759-111-68	IC uPC1237HA	
C602	1-126-934-11	ELECT	220uF 20% 10V	IC901	8-759-701-75	IC NJM7805FA	
C603	1-126-967-11	ELECT	47uF 20% 16V	< JACK >			
C900	1-136-153-00	FILM	0.01uF 5% 50V	JK101	1-774-411-11	JACK, PIN 6P (PHONO, TUNER, CD)	
C903	1-125-793-11	ELECT	8200uF 20% 56V (FE520R)	JK102	1-573-028-31	JACK, PIN 4P (AUX, TAPE2/MD REC OUT)	
C903	1-125-815-11	ELECT	6800uF 20% 50V (FE320R)	JK103	1-770-015-11	JACK, PIN 6P (TAPE2/MD IN, TAPE1/DAT REC OUT, IN)	
C904	1-125-793-11	ELECT	8200uF 20% 56V (FE520R)	< COIL >			
C904	1-125-815-11	ELECT	6800uF 20% 50V (FE320R)	L301	1-420-872-00	COIL, AIR-CORE 1.9uH	
C905	1-126-968-11	ELECT	100uF 20% 50V (FE320R)	L351	1-420-872-00	COIL, AIR-CORE 1.9uH	
C905	1-128-576-11	ELECT	100uF 20% 63V (FE520R)	< TRANSISTOR >			
C906	1-126-968-11	ELECT	100uF 20% 50V (FE320R)	Q101	8-729-141-26	TRANSISTOR 2SC3622A-LK	
C906	1-128-576-11	ELECT	100uF 20% 63V (FE520R)	Q102	8-729-119-77	TRANSISTOR 2SA1175-FEK	
C907	1-164-097-11	CERAMIC	0.022uF 50V	Q103	8-729-620-05	TRANSISTOR 2SC2603-EF (FE520R)	
C908	1-126-967-11	ELECT	47uF 20% 16V	Q104	8-729-620-05	TRANSISTOR 2SC2603-EF	
C909	1-126-967-11	ELECT	47uF 20% 16V	Q151	8-729-141-26	TRANSISTOR 2SC3622A-LK	
C910	1-126-933-11	ELECT	100uF 20% 16V	Q301	8-729-140-82	TRANSISTOR 2SA988-PAFAEA	
				Q351	8-729-140-82	TRANSISTOR 2SA988-PAFAEA	
				Q901	8-729-119-78	TRANSISTOR 2SC403SP-51	
				Q902	8-729-201-53	TRANSISTOR 2SA1015-GR	
				Q903	8-729-620-05	TRANSISTOR 2SC2603-EF	
				< RESISTOR >			
				R101	1-249-418-11	CARBON 1.2K 5% 1/4W	
				R102	1-249-411-11	CARBON 330 5% 1/4W	
				R104	1-247-871-11	CARBON 47K 5% 1/4W	
				R105	1-249-416-11	CARBON 820 5% 1/4W	

MAIN

Ref. No.	Part No.	Description		Remark	Ref. No.	Part No.	Description		Remark
R106	1-247-897-11	CARBON	560K	5%	1/4W	△R318	1-212-958-00	FUSIBLE	10 5% 1/2W F
R107	1-247-871-11	CARBON	47K	5%	1/4W	△R320	1-212-942-00	FUSIBLE	2.2 5% 1/2W F
R108	1-247-879-11	CARBON	100K	5%	1/4W	△R321	1-212-942-00	FUSIBLE	2.2 5% 1/2W F
R109	1-249-409-11	CARBON	220	5%	1/4W	△R322	1-212-942-00	FUSIBLE	2.2 5% 1/2W F
R110	1-249-417-11	CARBON	1K	5%	1/4W	R351	1-249-439-11	CARBON	68K 5% 1/4W
R111	1-249-417-11	CARBON	1K	5%	1/4W	R352	1-249-417-11	CARBON	1K 5% 1/4W
R112	1-249-417-11	CARBON	1K	5%	1/4W	R353	1-247-825-11	CARBON	560 5% 1/4W
R113	1-249-417-11	CARBON	1K	5%	1/4W	R354	1-249-439-11	CARBON	68K 5% 1/4W
R114	1-249-417-11	CARBON	1K	5%	1/4W	R355	1-247-721-11	CARBON	4.7K 5% 1/4W
R115	1-249-417-11	CARBON	1K	5%	1/4W	R356	1-247-760-11	CARBON	4.7K 5% 1/2W
R116	1-249-417-11	CARBON	1K	5%	1/4W	R362	1-247-715-11	CARBON	1.5K 5% 1/4W
R117	1-249-417-11	CARBON	1K	5%	1/4W	R363	1-249-460-11	CARBON	15K 5% 1/4W
R118	1-249-427-11	CARBON	6.8K	5%	1/4W	△R364	1-217-151-00	METAL	0.22 10% 2W F
R119	1-247-847-11	CARBON	4.7K	5%	1/4W	R365	1-249-467-11	CARBON	68K 5% 1/4W
R120	1-249-409-11	CARBON	220	5%	1/4W	△R366	1-212-950-00	FUSIBLE	4.7 5% 1/2W F
R121	1-247-871-11	CARBON	47K	5%	1/4W	△R368	1-212-958-00	FUSIBLE	10 5% 1/2W F
R122	1-247-835-11	CARBON	1.5K	5%	1/4W	R601	1-247-747-11	CARBON	470 5% 1/2W (FE320R)
R123	1-249-427-11	CARBON	6.8K	5%	1/4W	R601	1-247-749-11	CARBON	560 5% 1/2W (FE520R)
R124	1-247-847-11	CARBON (FE520R)	4.7K	5%	1/4W	R602	1-247-747-11	CARBON	470 5% 1/2W (FE320R)
R125	1-247-855-11	CARBON	10K	5%	1/4W	R602	1-247-749-11	CARBON	560 5% 1/2W (FE520R)
R126	1-247-879-11	CARBON	100K	5%	1/4W	R603	1-249-417-11	CARBON	1K 5% 1/4W
R151	1-249-418-11	CARBON	1.2K	5%	1/4W	R604	1-247-879-11	CARBON	100K 5% 1/4W
R152	1-249-411-11	CARBON	330	5%	1/4W	R605	1-249-439-11	CARBON	68K 5% 1/4W
R154	1-247-871-11	CARBON	47K	5%	1/4W	R606	1-249-431-11	CARBON	15K 5% 1/4W
R155	1-249-416-11	CARBON	820	5%	1/4W	R607	1-247-756-11	CARBON	2.2K 5% 1/2W
R156	1-247-897-11	CARBON	560K	5%	1/4W	R608	1-247-756-11	CARBON	2.2K 5% 1/2W
R157	1-247-871-11	CARBON	47K	5%	1/4W	R832	1-249-393-11	CARBON	10 5% 1/4W (FE520R)
R158	1-247-879-11	CARBON	100K	5%	1/4W	R902	1-247-750-11	CARBON	680 5% 1/2W (FE320R)
R159	1-249-409-11	CARBON	220	5%	1/4W	R902	1-247-751-11	CARBON	820 5% 1/2W (FE520R)
R160	1-249-417-11	CARBON	1K	5%	1/4W	R903	1-247-750-11	CARBON	680 5% 1/2W (FE320R)
R161	1-249-417-11	CARBON	1K	5%	1/4W	R903	1-247-751-11	CARBON	820 5% 1/2W (FE520R)
R162	1-249-417-11	CARBON	1K	5%	1/4W	R904	1-247-750-11	CARBON	680 5% 1/2W (FE320R)
R163	1-249-417-11	CARBON	1K	5%	1/4W	R904	1-247-751-11	CARBON	820 5% 1/2W (FE520R)
R164	1-249-417-11	CARBON	1K	5%	1/4W	R904	1-247-751-11	CARBON	820 5% 1/2W (FE520R)
R165	1-249-417-11	CARBON	1K	5%	1/4W	R905	1-247-750-11	CARBON	680 5% 1/2W (FE320R)
R166	1-249-417-11	CARBON	1K	5%	1/4W	R905	1-247-751-11	CARBON	820 5% 1/2W (FE520R)
R167	1-249-417-11	CARBON	1K	5%	1/4W	R907	1-247-752-11	CARBON	1K 5% 1/2W (FE320R)
R168	1-249-427-11	CARBON	6.8K	5%	1/4W	R907	1-247-753-11	CARBON	1.2K 5% 1/2W (FE520R)
R176	1-247-879-11	CARBON	100K	5%	1/4W	R908	1-247-752-11	CARBON	1K 5% 1/2W (FE320R)
R207	1-247-847-11	CARBON	4.7K	5%	1/4W	R908	1-247-753-11	CARBON	1.2K 5% 1/2W (FE520R)
R257	1-247-847-11	CARBON	4.7K	5%	1/4W	R910	1-247-725-11	CARBON	10K 5% 1/4W
R301	1-249-439-11	CARBON	68K	5%	1/4W	R912	1-247-725-11	CARBON	10K 5% 1/4W
R302	1-249-417-11	CARBON	1K	5%	1/4W	R916	1-247-835-11	CARBON	1.5K 5% 1/4W
R303	1-247-825-11	CARBON	560	5%	1/4W				
R304	1-249-439-11	CARBON	68K	5%	1/4W				
R305	1-247-721-11	CARBON	4.7K	5%	1/4W				
R306	1-247-760-11	CARBON	4.7K	5%	1/2W				
△R307	1-212-881-11	FUSIBLE	100	5%	1/4W	F			
R308	1-247-752-11	CARBON	1K	5%	1/2W				
R309	1-247-752-11	CARBON	1K	5%	1/2W				
△R310	1-212-982-00	FUSIBLE	100	5%	1/2W	F			
R312	1-247-715-11	CARBON	1.5K	5%	1/4W				
R313	1-249-460-11	CARBON	15K	5%	1/4W				
△R314	1-217-151-00	METAL	0.22	10%	2W	F			
R315	1-249-465-11	CARBON	47K	5%	1/4W				
△R316	1-212-950-00	FUSIBLE	4.7	5%	1/2W	F			

The components identified by mark △ or dotted line with mark △ are critical for safety. Replace only with part number specified.

MAIN

POWER SW

RELAY AC

RELAY DC

TAPE MON

Ref. No.	Part No.	Description	Remark	Ref. No.	Part No.	Description	Remark
		< RELAY >				< FUSE >	
RY101	1-515-614-11	RELAY (FE520R)		△F1	1-532-503-51	FUSE (T1.6AL/250V) (FE320R)	
RY601	1-515-920-11	RELAY (24V)		△F3	1-532-388-51	FUSE (T2AL/250V) (FE520R)	
		< TERMINAL >				< RELAY >	
TM301	1-537-894-11	TERMINAL BOARD (SP) (SPEAKERS)		△RY1	1-755-018-11	RELAY (AEP)	
* TM302	1-537-738-21	TERMINAL, EARTH		*****			

*	1-670-966-11	POWER SW BOARD		*	1-670-972-11	RELAY DC BOARD	
		*****				*****	
		< CAPACITOR >				< CAPACITOR >	
*	4-211-967-01	HOLDER (LED)		C901	1-106-379-12	MYLAR 0.033uF 5% 200V	
		< CONNECTOR >		C902	1-106-379-12	MYLAR 0.033uF 5% 200V	
				C912	1-136-153-00	FILM 0.01uF 5% 50V	
CN807	1-770-397-11	HOUSING, CONNECTOR (PC BOARD) 4P		C913	1-126-941-11	ELECT 470uF 20% 25V	
		< DIODE >				< CONNECTOR >	
D821	8-719-301-49	LED SEL2810A (EON LINK) (FE520R)		* CN903	1-564-506-11	PLUG, CONNECTOR 3P	
D822	8-719-302-45	LED SEL1210S (STANDBY)				< DIODE >	
		< IC >		D901	8-719-302-37	DIODE RBV-602	
IC803	8-749-014-66	IC NJL56H400A (B)		D904	8-719-200-82	DIODE 11ES2	
		< TRANSISTOR >		D905	8-719-200-82	DIODE 11ES2	
Q809	8-729-029-66	TRANSISTOR DTC114ESA (FE520R)		D906	8-719-200-82	DIODE 11ES2	
Q812	8-729-620-05	TRANSISTOR 2SC2603-EF (FE520R)		D907	8-719-200-82	DIODE 11ES2	
Q813	8-729-620-05	TRANSISTOR 2SC2603-EF (FE520R)		D908	8-719-200-82	DIODE 11ES2	
		< RESISTOR >		D909	8-719-200-82	DIODE 11ES2	
R831	1-249-399-11	CARBON 33 5% 1/4W		D910	8-719-911-19	DIODE 1SS119	
R833	1-247-839-11	CARBON 2.2K 5% 1/4W				< RESISTOR >	
R835	1-247-855-11	CARBON 10K 5% 1/4W		△R901	1-212-942-00	FUSIBLE 2.2 5% 1/2W F	
R836	1-247-847-11	CARBON 4.7K 5% 1/4W		R913	1-247-863-11	CARBON 22K 5% 1/4W	
R838	1-249-407-11	CARBON 150 5% 1/4W				< RELAY >	
		(FE520R)		RY901	1-755-018-11	RELAY	
		(FE520R)		RY902	1-755-018-11	RELAY	
		< SWITCH >		*****			
S1	1-571-112-21	SWITCH, PUSH (1 KEY) (I/⏏) (POWER)		*	1-670-969-11	TAPE MON BOARD (FE520R)	
S803	1-571-112-21	SWITCH, PUSH (1 KEY) (EON LINK) (FE520R)				*****	

*	1-670-971-11	RELAY AC BOARD		*	4-211-967-01	HOLDER (LED)	
		*****				< DIODE >	
		1-533-293-11	FUSE HOLDER	D823	8-719-301-49	LED SEL2810A (TAPE MONITER)	
		< CONNECTOR >				< SWITCH >	
* CN1	1-580-230-31	PIN, CONNECTOR (PC BOARD) 2P		S802	1-554-303-21	SWITCH, TACTILE (TAPE MONITER)	
CN2	1-564-321-00	PIN, CONNECTOR 2P (AEP)		*****			
* CN954	1-564-506-11	PLUG, CONNECTOR 3P (AEP)				MISCELLANEOUS	
		< DIODE >				*****	
D911	8-719-911-19	DIODE 1SS119 (AEP)		△56	1-770-019-11	ADAPTOR, CONVERSION PLUG 3P (UK)	
				△CP1	1-575-651-21	CORD, POWER	
				△T1	1-431-802-11	TRANSFORMER, POWER (FE520R)	
				△T1	1-431-803-11	TRANSFORMER, POWER (FE320R)	

The components identified by mark △ or dotted line with mark △ are critical for safety. Replace only with part number specified.

TA-FE320R/FE520R

<u>Ref. No.</u>	<u>Part No.</u>	<u>Description</u>	<u>Remark</u>
-----------------	-----------------	--------------------	---------------

HARDWARE LIST

#1	7-685-646-79	SCREW +BVTP 3X8 TYPE2 N-S	
#2	7-685-880-09	SCREW +BVTT 4X6 (S)	
#3	7-685-647-79	SCREW +BVTP 3X10 TYPE2 N-S	
#4	7-685-648-79	SCREW +BVTP 3X12 TYPE2 N-S	
#5	7-685-650-79	SCREW +BVTP 3X16 TYPE2 N-S	

ACCESSORIES & PACKING MATERIALS

1-473-655-31	REMOTE COMMANDER (RM-S325)	
3-862-730-11	MANUAL, INSTRUCTION (ENGLISH, FRENCH, SPANISH, PORTUGUESE)	
3-862-730-21	MANUAL, INSTRUCTION (GERMAN, DUTCH, SWEDISH, ITALIAN) (AEP)	
3-862-730-41	MANUAL, INSTRUCTION (ENGLISH, POLISH, RUSSIAN) (AEP)	
4-981-643-01	COVER, BATTERY (for RM-S325)	