

ONKYO SERVICE MANUAL

QUARTZ SYNTHESIZED TUNER AMPLIFIER MODELS TX-840/TX-840M



Black model

BHUD, BHUDN, MBHUDN	120V AC, 60Hz
BHUG	220V AC, 50Hz
BHUW	120/220V AC, 50/60Hz

SAFETY-RELATED COMPONENT WARNING!!

COMPONENTS IDENTIFIED BY MARK Δ ON THE SCHEMATIC DIAGRAM AND IN THE PARTS LIST ARE CRITICAL FOR RISK OF FIRE AND ELECTRIC SHOCK. REPLACE THESE COMPONENTS WITH ONKYO PARTS WHOSE PART NUMBERS APPEAR AS SHOWN IN THIS MANUAL.

MAKE LEAKAGE-CURRENT OR RESISTANCE MEASUREMENTS TO DETERMINE THAT EXPOSED PARTS ARE ACCEPTABLY INSULATED FROM THE SUPPLY CIRCUIT BEFORE RETURNING THE APPLIANCE TO THE CUSTOMER.

TABLE OF CONTENTS

Specifications	2
Service procedures	3
Exploded view	4
Parts list	5
Block diagram -120V model-	6
Block diagram -220V model-	8
Connection diagram of microprocessor	10
Block diagram of IC	11
Adjustment procedures	18
Pc board view/parts list	
Display/preamp./speaker	21
AM/FM tuner and selector circuit	25
Power amplifier	30
Other pc boards	33
Schematic diagram	
120V model -Tuner-	23
120V model -Amp.-	27
Other models -Tuner-	31
Other models -Amp.	35
Disassembling procedures	37
Packing view	38

ONKYO
AUDIO COMPONENTS

SPECIFICATIONS

AMPLIFIER SECTION

Power output:	60 watts per channel, min, RMS, at 8ohms, both channels driven, from 20Hz to 20kHz, with no more than 0.08% total harmonic distortion.
Musical Power Output:	2 × 160 watts at 4 ohms, 1kHz (DIN) 2 × 100 watts at 8 ohms, 1kHz (DIN)
Continuous Power Output:	2 × 90 watts at 4 ohms, 1kHz (DIN) 2 × 70 watts at 8 ohms, 1kHz (DIN)
Total Harmonic Distortion:	0.08% at rated power 0.08% at 1 watts output
IM Distortion:	0.08% at rated power 0.08% at 1 watts output
Damping Factor:	40 at 8 ohms
Frequency Response:	20-30,000Hz ±1dB
RIAA Diviation:	20-20,000Hz ±0.8dB
Sensitivity and Impedance:	Phono: 2.5mV/50 kohms CD: 150mV/50 kohms Tape Play: 150mV/50 kohms Tape Rec: 150mV/3.5 kohms
Phono Overload(MM):	120mV RMS at 1kHz, 0.08% THD.
Signal-to-Noise Ratio:	Phono: 85dB(at 10mV input, A weighted) 75dB(IHF A-202) CD/Tape: 95dB(A weighted) 80dB(IHF A-202)
Tone controls:	Bass: ±10dB at 100Hz Treble: ±10dB at 10kHz

TUNER SECTION

	-220V/ Worldwide models-	-120V model-
FM:		
Tuning Range:	87.50-108.00MHz(50kHz steps) 87.50-108.00MHz(50kHz steps) or 87.9-107.9kHz(200kHz steps) (Worldwide model)	87.9-107.9kHz(200kHz steps)
Usable Sensitivity:	Mono: 12.8dBf, 1.2 μV, 75ohms 1.0 μV(S/N 26dB, 40kHz Devi.) 75ohms DIN Stereo: 18.0dBf, 2.2 μV, 75ohms 23μV(S/N 46dB, 40kHz Devi.) 75ohms DIN	Mono: 11.2dBf, 2.0 μV Stereo: 17.2dBf, 4.0 μV
50dB Quieting Sensitivity:	Mono: 18.0dBf, 2.2 μV, 75ohms Stereo: 37.2dBf, 20μV, 75ohms	Mono: 17.2dBf, 4.0 μV Stereo: 37.2dBf, 40μV
Capture Ratio:	1.5dB	1.5dB
Image Rejection Ratio:	85dB	40dB
IF Rejection Ratio:	90dB	90dB
Signal-to-Noise Ratio:	Mono: 72dB Stereo: 66dB	Mono: 72dB Stereo: 66dB
Alternate Channel Attenuation:		55dB
Selectivity:	50dB DIN(±300kHz, 40kHz dev.)	
AM suppression Ratio:	50dB	50dB
Harmonic Distortion:	Mono: 0.15% Stereo: 0.30%	Mono: 0.15% Stereo: 0.30%
Frequency Response:	30-15,000Hz ±1.5dB	30-15,000Hz ±1.5dB
Stereo Separation:	45dB at 1kHz 30dB at 100-10,000Hz	45dB at 1kHz 30dB at 100-10,000Hz
Muting Level:	17.2dBf, 4.0μV	17.2dBf, 4.0μV
AM:		
Tuning Range:	522-1611kHz(9kHz steps) 522-1611kHz(9kHz steps) or 530-1620kHz(10kHz steps) (Worldwide model)	530-1620kHz(10kHz steps)
Usable Sensitivity:	30μV	30μV
Image Rejection Ratio:	40dB	40dB
IF Rejection Ratio:	40dB	40dB
Signal-to-Noise Ratio:	40dB	40dB
Harmonic Distortion:	0.7%	0.7%

GENERAL

Dimensions(W×H×D):	435×130×351mm 17-1/8"×5-1/8"×13-13/16"
Weight:	8.2kg., 18.1lbs.

Specifications and features are subject to change without notice.

SERVICE PROCEDURES

1. Replacing the fuses

For continued protection against fire hazard, replace only with same type and same rating fuse.

D (120V) model

Circuit no.	Part no.	Description
F901	252050	5 A (ST-6), Primary

G (220V) model

Circuit no.	Part no.	Description
F902	252075	2.5A-SE-EAK, Primary
F903	252075	2.5A-SE-EAK, AC outlet

W (Worldwide) model

Circuit no.	Part no.	Description
F901	252050	5 A (ST-6), Primary
F902	252075	2.5A-SE-EAK, Primary

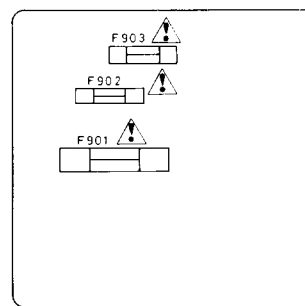

POWER SUPPLY CIRCUIT PC BOARD

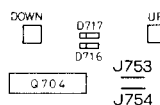

DISPLAY PC BOARD

2. Change of FM/AM band step.

With the exception of the models below, a BAND STEP selector switch is not provided.

(FM)

MODEL	BAND STEP	D717, J753	R119
UD	200kHz→50kHz	Additional	15kΩ→24kΩ
UG/UQ	50kHz→200kHz	Eliminated	24kΩ→15kΩ

(AM)

BAND STEP	D716, J754
10kHz→9kHz	Additional
9kHz→10kHz	Eliminated

In D716/7 1SS133 (Part No. 223163) is used. In J753/4, a jumper lead must be inserted. R119, with the muting amplitude determined, is on the back panel side of FM/AM tuner and selector circuit printed circuit board assembly test points TP-1 and TP-2.

– Worldwide model –

Worldwide models are equipped with a step band selector switch. This switch is located on the back panel. This switch is set to 50kHz (FM) and 9kHz (AM) at the factory, but may have to be reset to 200kHz and 10kHz depending on the area where the unit is used.

	De-emphasis	FM step	AM step
Europe:	50 μsec	50 kHz	9 kHz
U.S.A.:	75 μsec	200 kHz	10 kHz

3. Memory preservation

This unit does not require memory preservation batteries. A built-in memory power back-up system preserves contents of the memory during power failures and even when the unit is unplugged. The unit must be plugged in

and the power switch turned on and off once in order to charge the back-up system. Note that since this is not a permanent memory the power switch must be turned on and off a few times each month to keep the back-up system operative. The period of time during which memory contents are preserved after power has last been turned off varies depending on climate and placement of the unit. On the average, memory contents are protected over a period of 3 to 4 weeks (a minimum of 2 weeks) after the last time power has been turned off. This period is shorter when the unit is exposed to very high humidity or used in an area with an extremely humid climate.

4. Safety-check out

(Only U.S.A. model)

After correcting the original service problem perform the following safety check before releasing the set to the customer.

Connect the insulating-resistance tester between the plug of power supply cord and terminal GND on the back panel. Specifications: 3.3 Mohm ±10% at 500V.

5. Change of voltage

Worldwide models are equipped with a voltage selector to conform with local power supplies. This switch is located on the back panel. Be sure to set this switch to match the voltage of the power supply in your area before turning the power switch on.

This switch is set to 220V at the factory. Voltage is changed by sliding the groove in the switch with the screwdriver to the right or left. Confirm that the switch has been moved all the way to the right or left before turning the power switch on.

EXPLODED VIEW

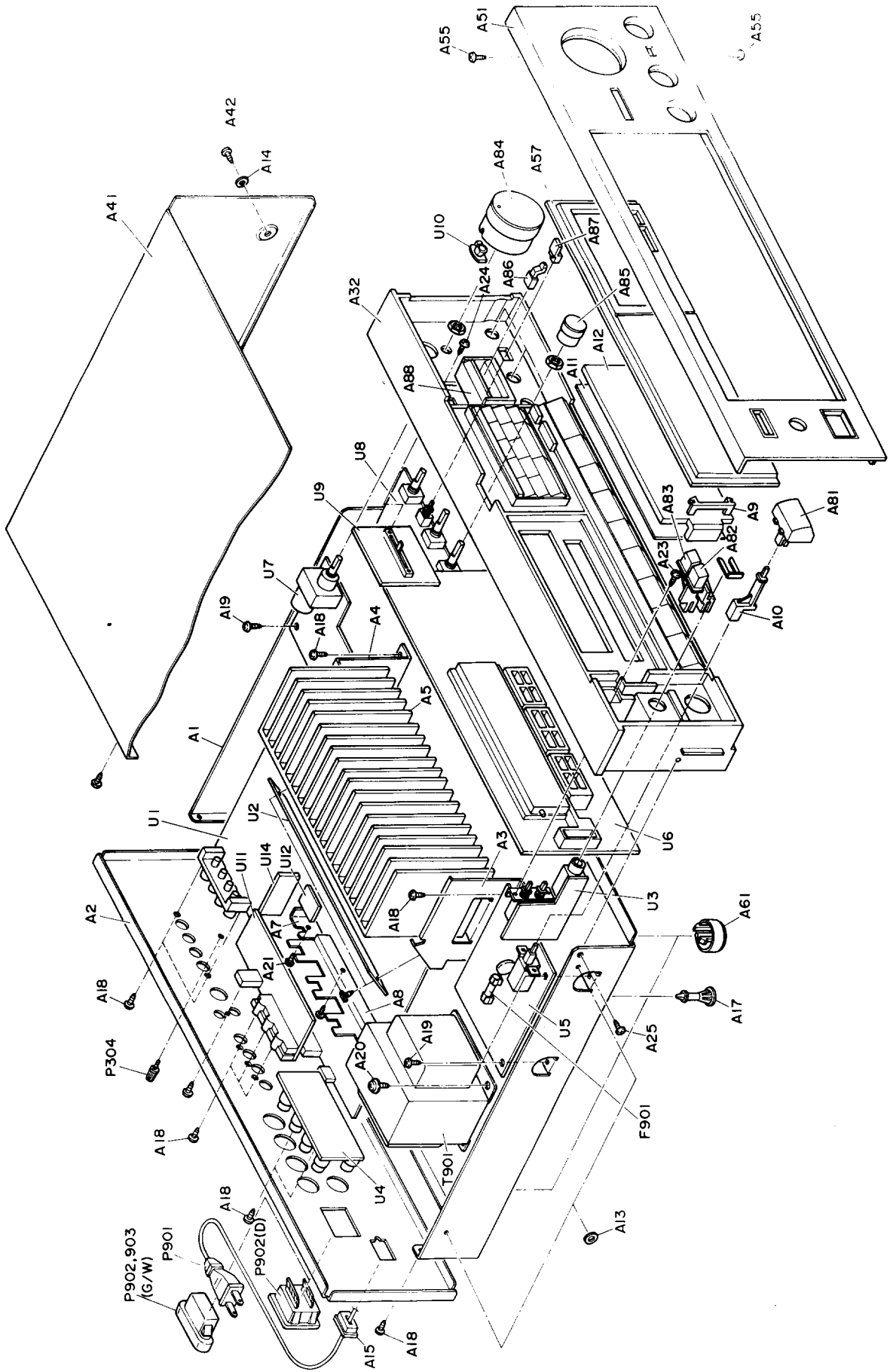

PARTS LIST

REF. NO.	PART NO.	DESCRIPTION	REF. NO.	PART NO.	DESCRIPTION	REF. NO.	PART NO.	DESCRIPTION
A1	27100163-1	Chassis	P901	253148 or 253150	△ AS-CEE,Power supply cord <G/W>	U8	1A158583-4	NAAF-3283-4, Preampifier board ass'y <D>
A2	27121254	Back panel <D>	P902	25050341	△ NSCT-4P168T,AC outlet <D>	U9	1A158583-4A	NAAF-3283-4A,Preampifier board ass'y <G/W>
A3	27121254-1	Back panel <G>	P902,P903	25050337	△ NSCT-2P164,AC outlet <G/W>	U10	1A158584-4	NAAF-3284-4, Switch pc board ass'y
A4	27121254-2	Back panel <W>	Q521,Q522	2501703, 2501704 or 2501706	2SC3855(O), 2SC3855(Y) or 2SC3855(P),Power amplifier transis-tor	U11	1A158585-4	NADIS-3285-4, Volume indicator pc board ass'y <D>
A5	27141261A	Bracket LH	Q523,Q524	2501693, 2501694 or 2501696	2SA1491(O), 2SA1491(Y) or 2SA1491(Y) or 2SA1491(P),Power amplifier transis-tor	U12	1A158586-4	NAETC-3286-4, Video terminal pc board ass'y <D>
A7	27160226A	Radiator	S903	25065123	△ NSS-1258P,Voltage selector switch <W>	U14	1A073554-2	NAAF-3054-2, Equalizer amplifier pc board ass'y <D>
A8	27141263	Bracket SH	T901	2300306	△ NPT-993D, Power transformer <D>	U14	1A086554-3	NAAF-3054-3, Equalizer amplifier pc board ass'y <G/W>
A9	27141264	Bracket H	U1	1A158576-4	NAAR-3276-4, FM/AM tuner and selector circuit pc board ass'y <D>	NOTE:	<D >: Only 120V model	
A10	27273098B	Holder,dial plate	U1	1A158576-4A	NAAR-3276-4A,FM/AM tuner and selector circuit pc board ass'y <G>	<G >: Only 220V model	<W >: Only Worldwide model	
A11	28133225	Joint,power	U2	1A158576-4B	NAAR-3276-4B,FM/AM tuner and selector circuit pc board ass'y <W>			
A12	28130256	Back plate	U2	1A158577-4	NAAF-3277-4, Power amplifier pc board ass'y			
A13	27270147	Dial plate	U3	1A158578-4	NASW-3278-4, Speaker switch pc board ass'y <D/W>			
A14	870048	Spacer <G/W>	U4	1A158579-4	NAETC-3279-4, Speaker terminal pc board ass'y <D>			
A15	27300750	3 × 8 × 0.8t,Nylon washer <G/W>	U5	1A158580-4	NAETC-3280-4, Const. voltage circuit pc board ass'y			
A17	27190524	△ Strainrelief	U6	1A158581-4	NADIS-3281-4, Display pc board ass'y <D>			
A18	834430088	Holder	U7	1A158581-4A	NADIS-3281-4A,Display pc board ass'y <G>			
A19	831130088	3TTS+8B(BC),Tapping screw		1A158581-4B	NADIS-3281-4B,Display pc board ass'y <W>			
A20	830440089	3TTW+8B,Tapping screw		1A158582-4	NAAF-3282-4, Volume pc board ass'y <D>			
A21	834430108	4TTC+8C(BC),Tapping screw		1A158574-1	NAAF-3574-1, Volume pc board ass'y <G/W>			
A22	8243006	3TTS+10B(BC),Tapping screw						
A23	82142004	3P+6FN(BC),Pan head screw						
A24	82142006	2P+4F(BC),Pan head screw						
A25	833430080	3TTP+8P(BC),Pan head screw						
A32	27110491A	Front bracket ass'y						
A41	28184394	Top cover						
A42	834430088	3TTS+8B(BC),Tapping screw						
A51	1A158121	Front panel ass'y						
A55	833430080	3TTP+8P(BC),Tapping screw						
A57	28191466-1A	Clear plate						
A61	27175221A	Leg						
A81	28323241-1A	Knob POWER						
A82	28323361	Knob SPEAKER A						
A83	28323363	Knob SPEAKER B						
A84	28323365B	Knob VOLUME						
A85	28323310	Knob TONE						
A86	28322925	Knob SLIDE						
A87	28323367	Knob PUSH						
A88	27190647	Holder SLIDE						
F901	252050	△ 5A(ST-6),Primary fuse <D/W>						
F902	252075	△ 2.5A-SE-EAK,Primary fuse <G/W>						
F903	252075	△ 2.5A-SE-EAK,AC outlet fuse <G>						
P304	25060044	14 × 3mm,Terminal GROUND						
P901	253123, 253136, 253140 or 253146	△ AS-UC-6 #18,Power supply cord <D>						

NOTE: THE COMPONENTS IDENTIFIED BY MARK△ ARE CRITICAL FOR RISK OF FIRE AND ELECTRIC SHOCK. REPLACE ONLY WITH PART NUMBER SPECIFIED.

BLOCK DIAGRAM

-120V MODEL- TUNER SECTION

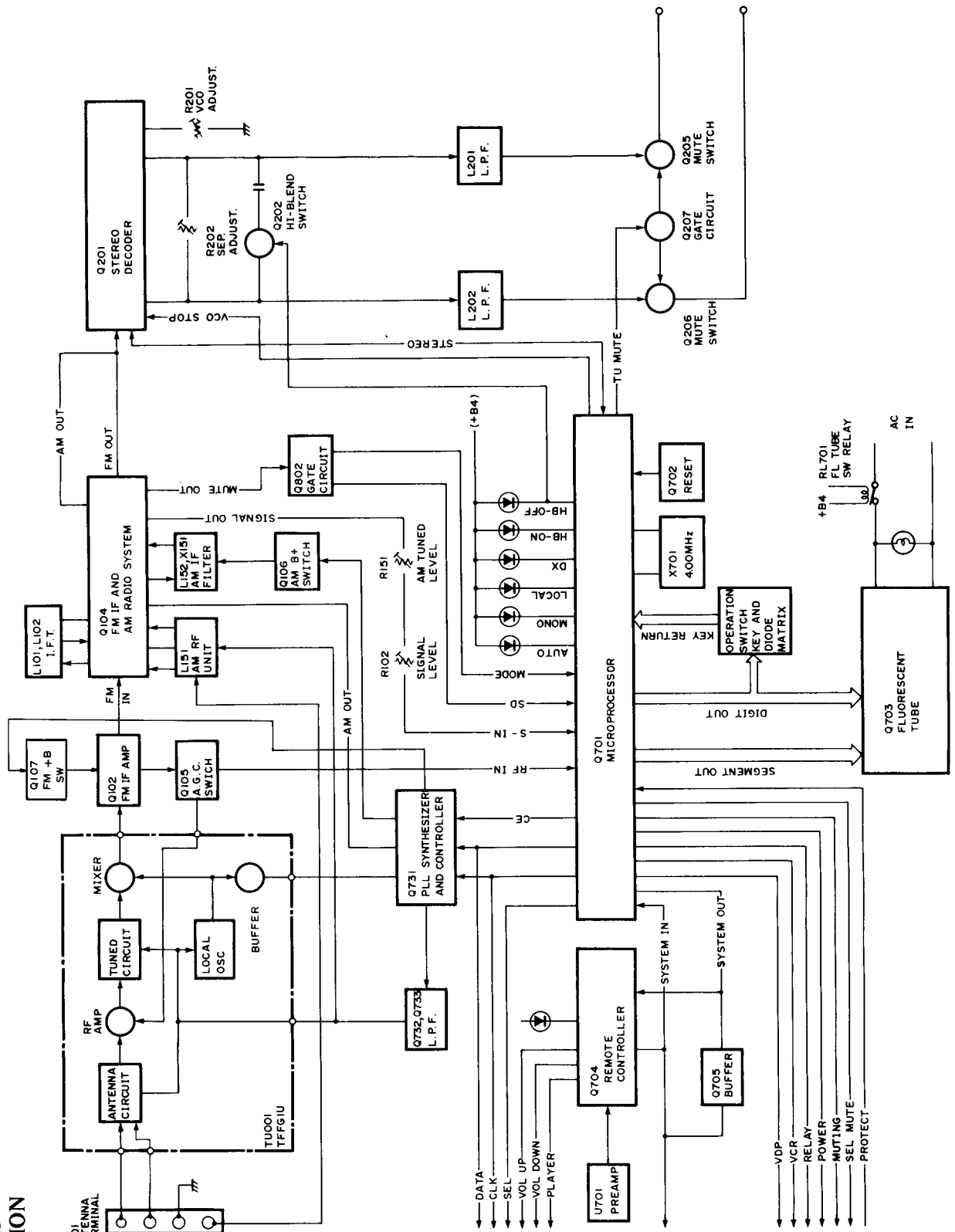

AMPLIFIER SECTION

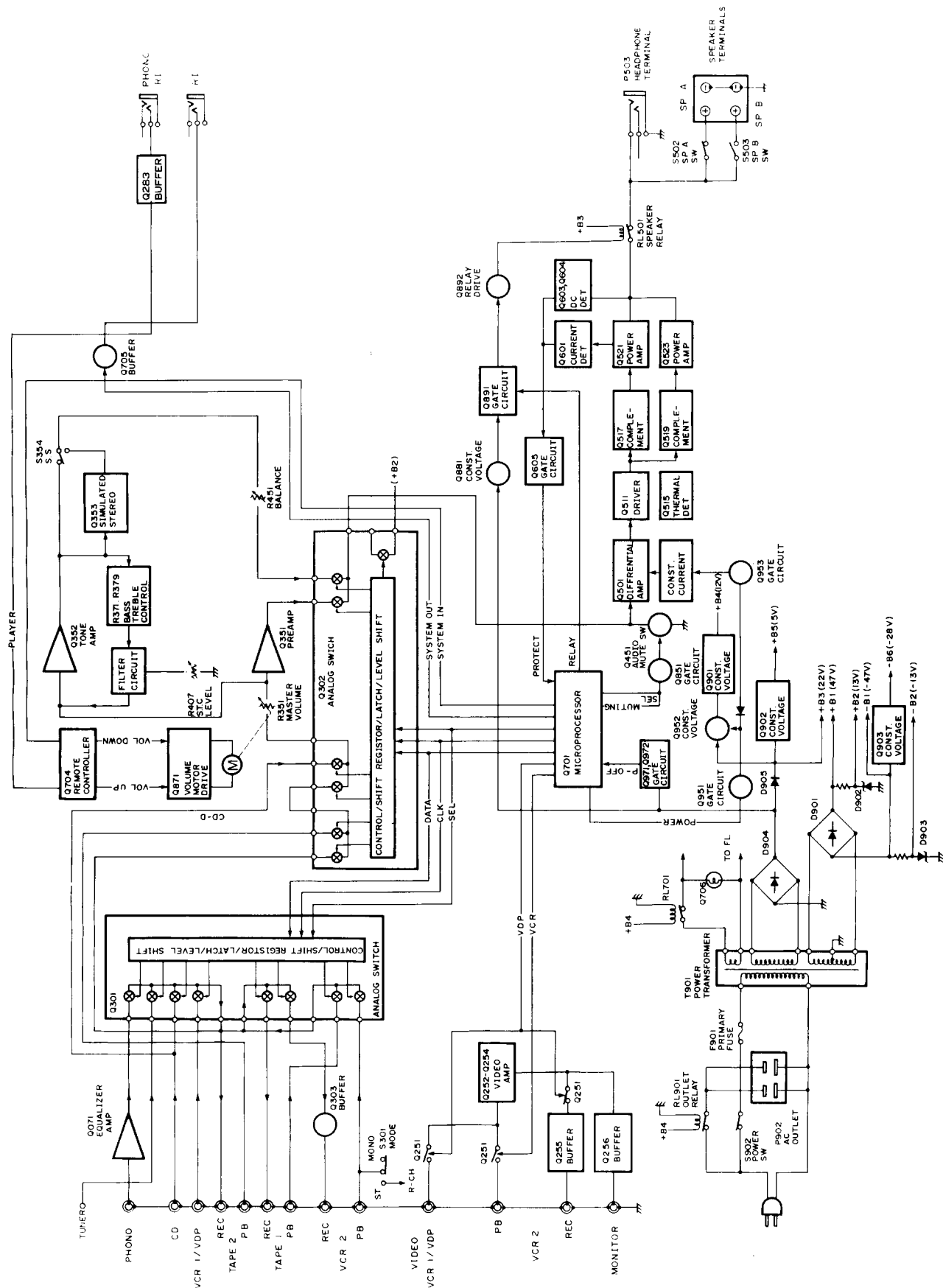

BLOCK DIAGRAM

—OTHER MODELS— TUNER SECTION

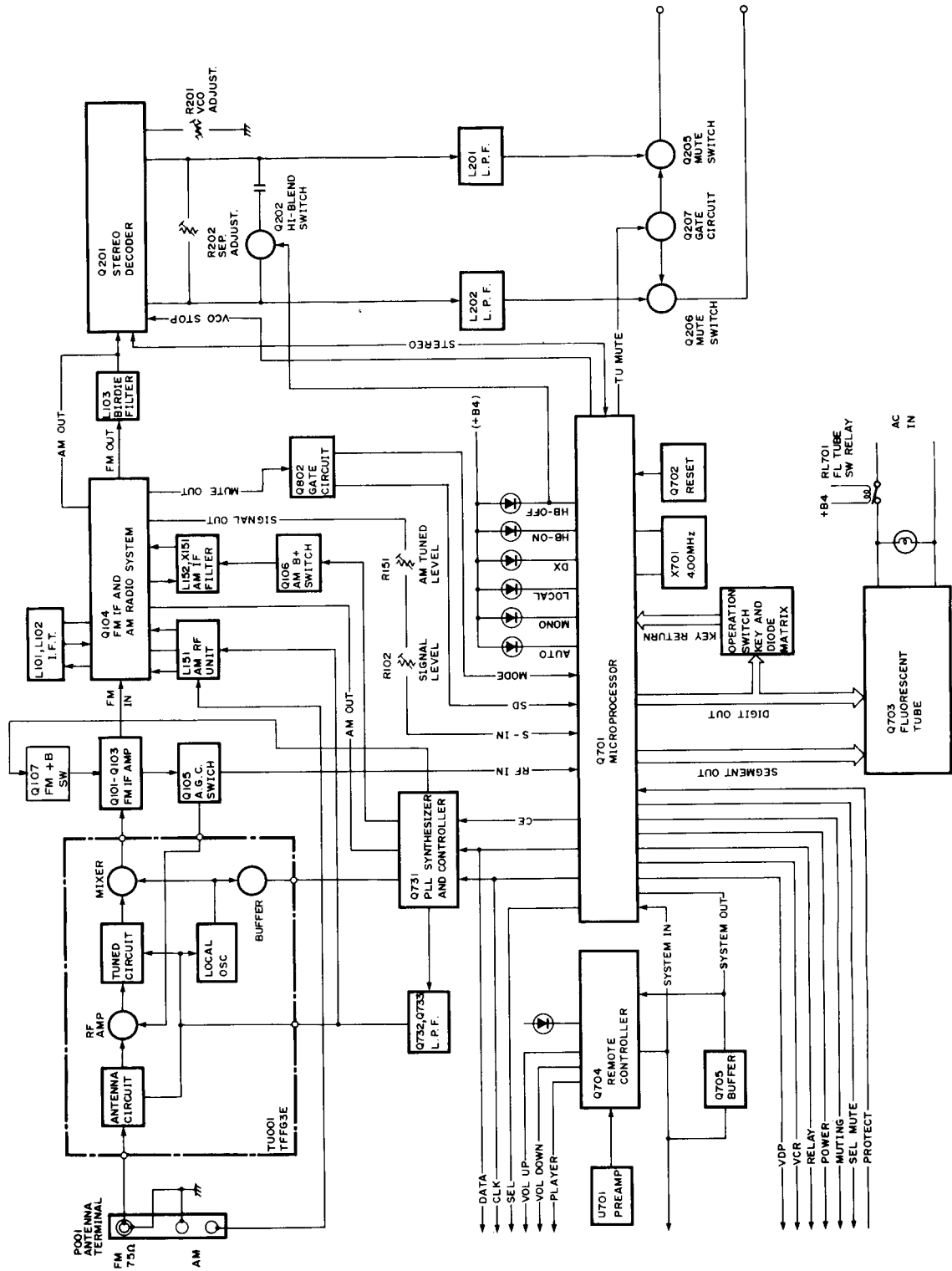

AMPLIFIER SECTION

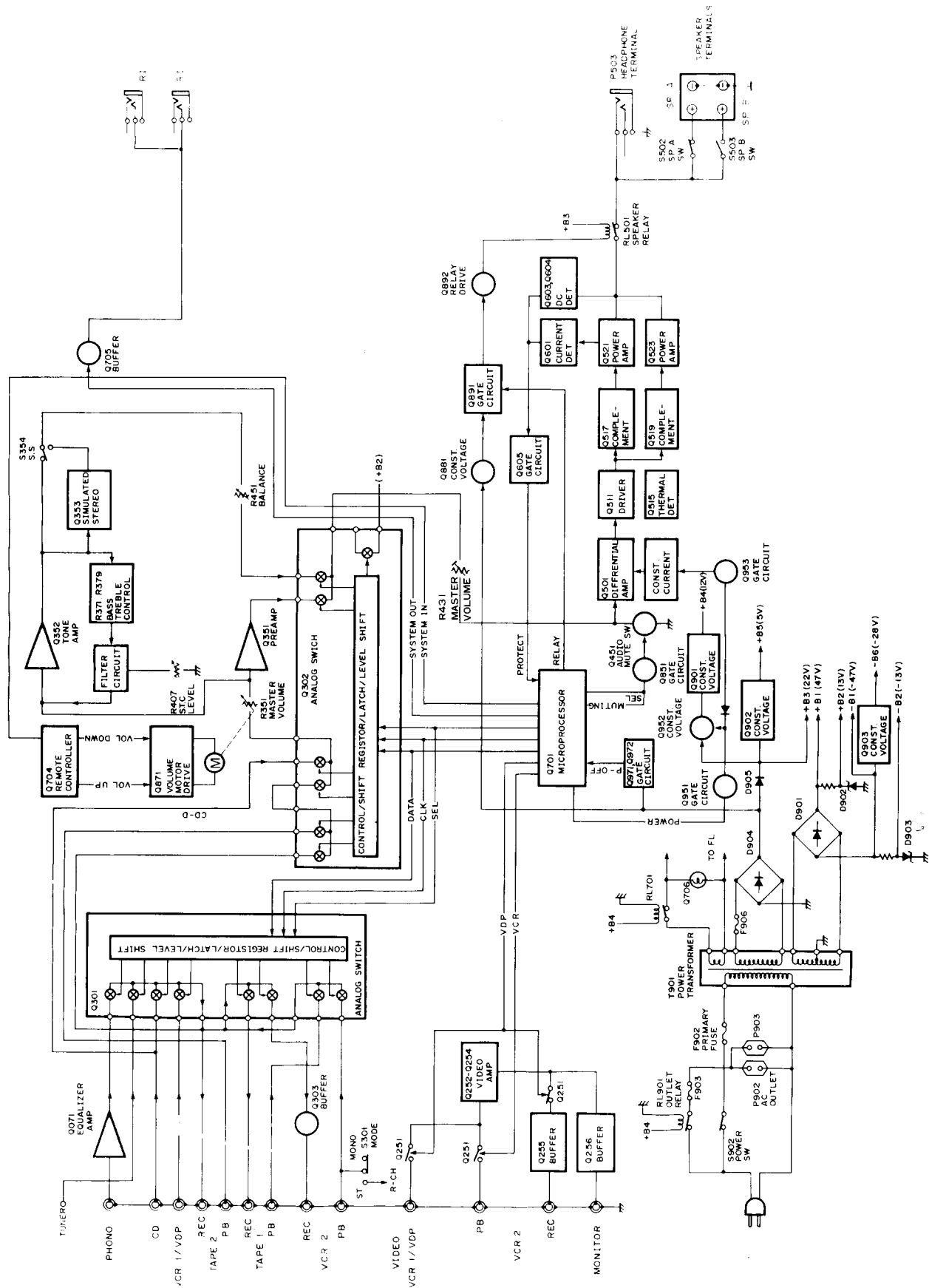

CONNECTION VIEW OF MICROPROCESSOR

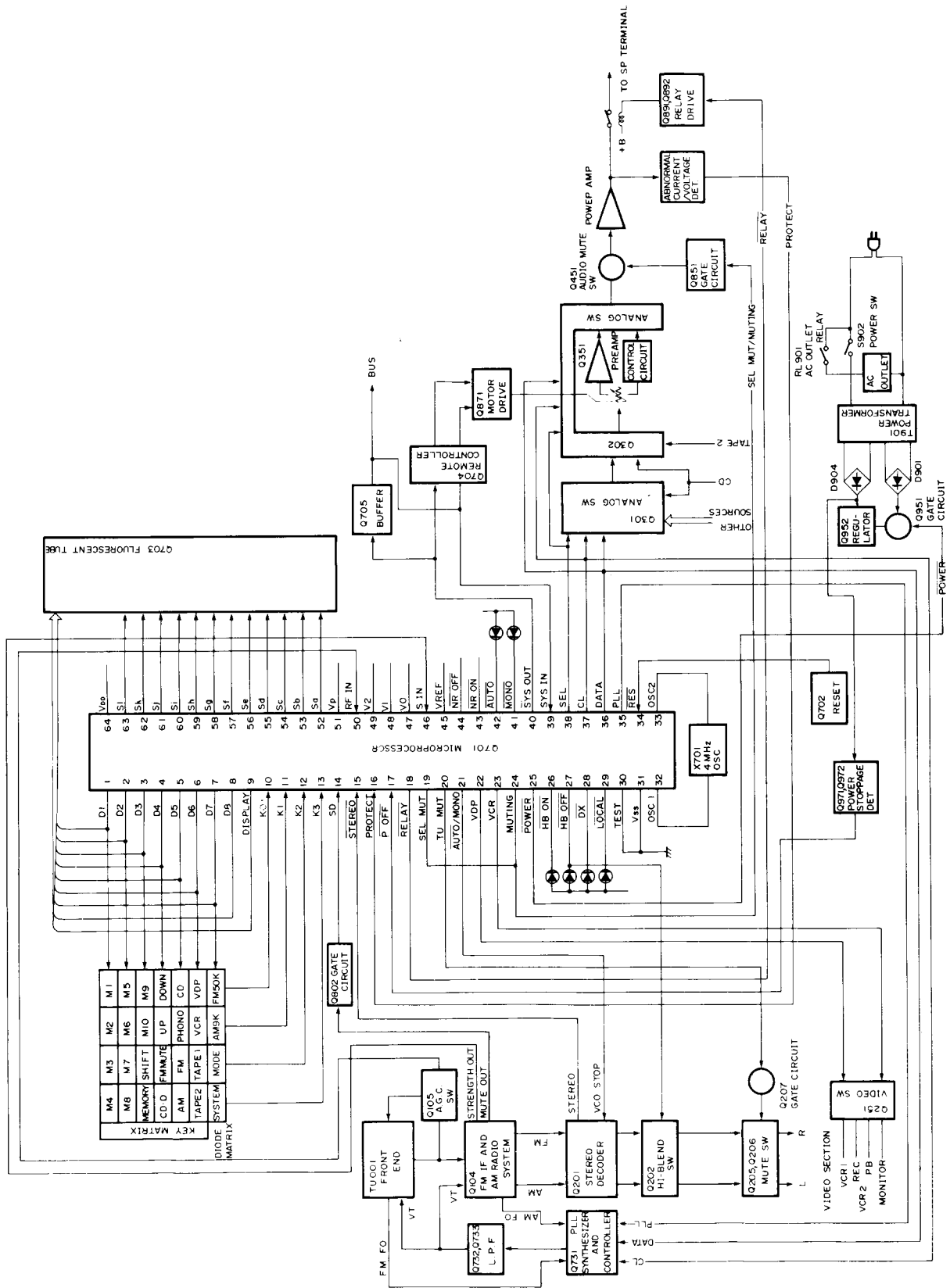

BLOCK DIAGRAM OF ICS

LC6568H-3643 (MICROPROCESSOR)

Terminal Descriptions

Pin No.	Terminal	Description
1	D1	These are the digit and key scan signal terminals. "H" when active.
2	D2	
3	D3	
4	D4	
5	D5	
6	D6	
7	D7	
8	D8	
9	DISPLAY	Display output terminal."H" when active.
10	K0	These are the input terminal for key return signal source and diode matrix."H" when active.
11	K1	
12	K2	
13	K3	
14	SD	Auto stop signal input terminal.Auto tuning stops when this terminal becomes the high level.
15	STEREO	This is the input terminal for detection of the stereo broadcast."L" when active.
16	PROTECT	This is the detection terminal for protection circuit.The speaker relay turns off when this terminal becomes the high level.
17	POWER OFF	This is the input terminal for detection of the stoppage of electric current."L" when the stoppage of electric current.
18	RELAY	This is the output terminal for control of the speaker relay."L" when active.
19	SEL MUTE	This is the muting output terminal when the selector key is operated."H" when active.
20	TU MUTE	This is the output terminal for muting control of tuner section."L" when active.
21	AUTO/MONO	This is the AUTO/MONO switching output terminal. "L" when AUTO.
22	VDP	These are the output terminal for control of video signal.
23	VCR	
24	MUTING	This is the output terminal for muting control. "H" when active.
25	POWER	This is the output terminal for power source.It is "H" for power on.
26	HB ON	This is the output terminal for indication of HI-BLEND ON. "L" when active.
27	HB OFF	This is the output terminal for indication of HI-BLEND OFF. "L" when active.
28	DX	This is the output terminal for indication of DX. "L" when active.
29	LOCAL	This is the output terminal for indication of LOCAL. "L" when active.
30	TEST	Test terminal.Connect to the ground.
31	Vss	Ground terminal.
32	OSC1	Connect to the 4.00MHz ceramic oscillator.
33	OSC2	
34	RES	This is the input terminal for reset. "L" when active
35	PLL	Connect to the terminal CE of PLL IC(LM7001).
36	DATA	This is the serial data output terminal.Connect to the terminal DATA of PLL IC and terminal DI of analog switches. (LC7821/LC7823)
37	CLOCK	This is the serial clock output terminal.Connect to the terminal CI of PLL IC and terminal CL of analog switches.
38	SEL	Connect to terminal SEL of analog switch(LC7821).
39	SYSTEM IN	This is the input terminal for system code. "H" when active.
40	SYSTEM OUT	This is the input terminal for system code. "L" when active.
41	MONO	This is the output terminal for indication of MONO. "L" when active.
42	AUTO	This is the output terminal for indication of AUTO. "L" when active.
43	NR ON	This is the output terminal for indication of NR ON. "L" when active.
44	NR OFF	This is the output terminal for indication of NR OFF. "L" when active.
45	VREF	This is the input terminal for comparator reference voltage.
46	S IN	This is the signal strength input terminal.
47	V0	This is the output terminal for comparator reference voltage.
48	V1	This is the output terminal for comparator reference voltage.
49	V2	This is the output terminal for comparator reference voltage.
50	RF IN	This is the input terminal for control of AGC. "H" when active.
51	VP	Pull-down resistor connection terminal of FIP controller/driver.

Pin No.	Terminal	Description
52	Sa	These are the output terminal for segment signal. "H" when active.
53	Sb	
54	Sc	
55	Sd	
56	Se	
57	Sf	
58	Sg	
59	Sh	
60	Si	
61	Sj	
62	Sk	
63	Sl	
64	VDD	This is the device power source terminal. At the time of operation, the supply is 5V. The internal data memory (RAM) is maintained by means of the super capacitor.

FM50K (FM band setting)

FM50K	Region	Frequency range	Channel space	Reference frequency	IF frequency
1	Europe	87.50 ~ 108.00MHz	50kHz	25kHz	10.7MHz
0	U.S.A.	87.9 ~ 107.9MHz	200kHz	25kHz	10.7MHz

ADJUSTMENT PROCEDURES

Preparation

• Input

FM mono: 1kHz, 75kHz devi., 60dB/ μ V

FM stereo: 1kHz, L+R 67.5kHz devi.: Pilot signal 19kHz
7.5kHz devi.

AM: 400Hz, 30% mod.,

• Output

Connect the non-inductive type resistor of 8 ohms to the speaker terminal A of left and right channels unless otherwise noted.

• Standard knob position

TAPE MONITOR	SOURCE
VOLUME	Maximum
BASS/TREBLE/BALANCE	Center
VCR 2 MODE	STEREO
SPEAKER	A
SIMULATED STEREO	OFF

Amplifier section

1. Idling current adjustment

Connect the DC voltmeter to the terminals IID and VCT on the power amplifier pc board.

Adjust the semi-fixed resistors R533 and R534 so that the indication of voltmeter is 7.5 ± 1.5 mV.

Notes: VOLUME Maximum, Open load,
Adjust after switching on for 5 minutes.

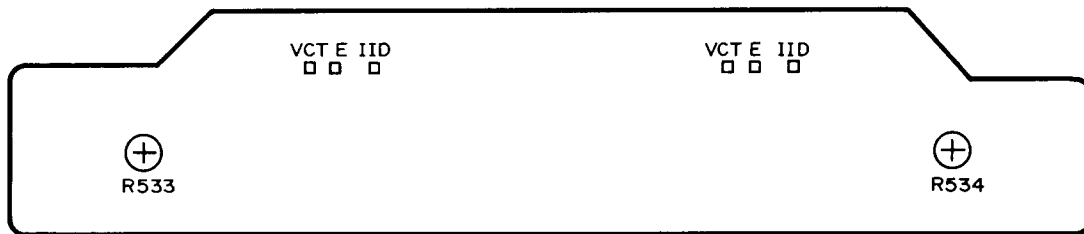

Power amplifier pc board

Section

Item	Step	Connection of instrument	FM SG output	Stereo modulator output	Turning dial setting	Output indicator	Adjustment	Adjust for	Remarks
FM IF	1		99.1MHz 1kHz, 75kHz devi. 65dB (60dB)		99.1MHz	DC voltmeter	L101	0V ± 20mV	Mode switch: MONO
	2	Fig. 1				AC voltmeter	IF on the front end	Maximum	Repeat the steps 1 and 3 until no further adjustment is necessary
	3					Distortion analyzer	L102	Minimum	
Stereo indicator level	1	Fig. 3	99.1MHz 17.2dB (12dB) Ext. modulation	L + R: 1kHz 67.5kHz devi.	99.1MHz	Stereo indicator	R101	Light on	Mode switch: STEREO
	2		99.1MHz 16.2dB (11dB) Ext. modulation	Pilot signal 1.9kHz 7.5kHz devi.				Light off	
VCO		Fig. 2	99.1MHz 1kHz, 75kHz devi. 65dB (60dB)		99.1MHz	Frequency counter	R201	19kHz ± 10Hz	
Stereo distortion	1	Fig. 3	99.1MHz 65dB (60dB) Ext. modulation	L or Rch. 1kHz	99.1MHz	Distortion analyzer	IF on the front end	Minimum	Don't turn more than ± 180°
	2	Fig. 3	99.1MHz 65dB (60dB) Ext. modulation	Lch. 1kHz Rch. 1kHz	99.1MHz	Rch. AC voltmeter Lch. AC voltmeter	R202	Minimum	Maximum and same separation
Blend level		Fig. 3	99.1MHz 35.2dB (30dB) 1kHz, 75kHz devi.		99.1MHz	Hi-Blend indicator	R102	Light off	

Section

Item	AM SG output	Tuned frequency	Output indicator	Adjustment point	Adjust for
	530kHz	530kHz (522kHz) (531kHz)	Digital DC voltmeter	OSC on RF block	1.3V ± 0.1V
	600kHz (603kHz) 400Hz 30% mod. 60dB/m	600kHz (603kHz)	AC voltmeter	RF on RF block	Maximum
	1000kHz (999kHz) 400Hz 30% mod. 60dB/m	1000kHz (999kHz)	AC voltmeter	L152	Maximum
	Same as above	1000kHz (999kHz)	First signal indicator	R151	Light on

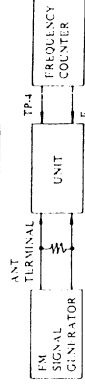
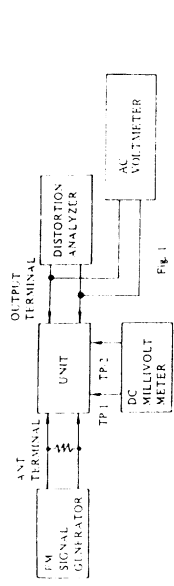

Use the high impedance probe. (10:1)

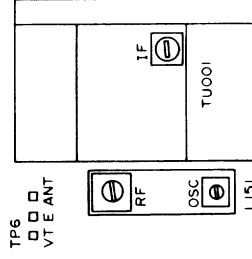
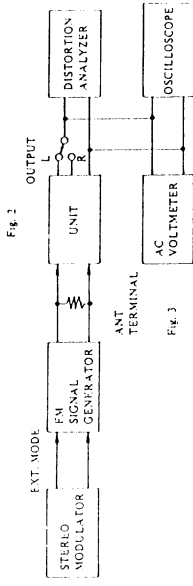

TP6
VT E ANT

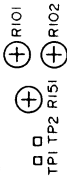
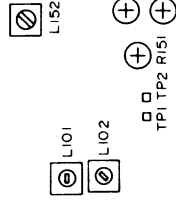
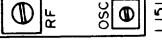

FM/AM tuner and selector switch pc board

DISPLAY PC BOARD PRINTED CIRCUIT BOARD-PARTS LIST

DISPLAY PC BOARD(NADIS-3281-4/4A/4B)

CIRCUIT NO.	PART NO.	DESCRIPTION
U701	24130001 or 24130003	GP1U501S or GP1U501XS
Q701	22240153	LC6568H-3643
Q704	22240243	LC6527C-3987
Transistors		
Q702	2211255, 2212485 or 2210746	2SC1815(GR), JC501(Q) or 2SC945A(P)
Q705	2211455, 2212495 or 2210803	2SA1015(GR), JA101(Q) 2SA733(P)
Fluorescent tube		
Q703	212054	7-BT-95GK
Lamp		
Q706	210064B	6.3V,0.25A
Diodes		
D702-D715	223163	1SS133
D716,D717	223163	1SS133 <G/W>
D718	224650822, 224150822 or 224450822	05AZ8.2Y or HZ8.2EB2 MTZ8.2B
D719	223163	1SS133
D720	224150562, 224450562 or 224650562	05AZ5.6Y, MTZ5.6B or HZ5.6EB2
D733-D736	223163	1SS133
L.E.Ds		
D723,D725	225137CG, 225137DG or 224137DY	SEL2413ECG, SEL2413EDG or SEL2413EDY
D724,D726	225142	SEL2913K
D728	225142	SEL2913K

D731	225141	SEL2213C
Osc. elements		
X701	3010099	CSA4.00MG,Ceramic
X702	3010150	CSA4.00MGW
Capacitors		
C702	3020027 or 3000051	0.047F,5.5V or 0.047F,5.5V,Super
C704	354780109	1 μ F,50V,Elect.
C707,C715	354782299	0.22 μ F,50V,Elect.
C708	354741009	10 μ F,16V,Elect.
Resistors		
R710	49163473404	47kohm \times 4, 1/10W,Network
R734,R735	49163104404	100kohm \times 4,1/10W,Network
Switches		
S701-S724	25035548	NPS-111-S510
S725	25065286	NSS-22112.Band <W>
Relay		
RL701	25065298	NRL-1P1A-DC12-40
Holder		
	27190643A	L.E.D

SPEAKER TERMINAL PC BOARD(NASW-3279-4/4A)

CIRCUIT NO.	PART NO.	DESCRIPTION
P501,P502	25060110 or 25060039	NTM-4PDMN44 or NTM-4PDMN10, Speaker terminals

PREAMPLIFIER PC BOARD(NAAF-3283-4/4A)

CIRCUIT NO.	PART NO.	DESCRIPTION
Q352	222579 or	NJM4560D or

Q353	222570	NJM4560DX
	222465 or	NJM4558D or
	222502	NJM4558DX
Transistor		
Q851	2212600	DTA124ES
Capacitors		
C359,C360	354780229	2.2 μ F,50V,Elect.
C363,C364	354741009	10 μ F,16V,Elect.
C367,C368	352983396	0.33 μ F,50V,Non-polar elect.
C373,C374	354780229	2.2 μ F,50V,Elect.
C375-C378	354781099	0.1 μ F,50V,Elect.
C389	354780229	2.2 μ F,50V,Elect.
C851	354780339	3.3 μ F,50V,Elect.
Resistors		
R371,R372	5104216	N14RLC50KC22Z, Variable,Bass
R379,R380	5104216	N14RLC50KC22Z, Variable,Treble
R451	5104225	N11RGLC250KW22Z, Variable,Bal- ance
Switch		
S354	25035590	NPS-122-L552

SPEAKER SWITCH PC BOARD(NASW-3278-4/4A)

CIRCUIT NO.	PART NO.	DESCRIPTION
L501,L502	231001	S-1.3B,Coils
R549,R550	442520474	4.7ohm,1/2W,Metal oxide film resistors
R551,R552	441623914	390ohm,1W,Metal oxide film resistors
S502,S503	25035517	NPS-222-L479,Push switch
P503	25045187	HLJ-0541-01-010,Stereo headphone terminal <D/W>
	25045139	HLJ-0540-01-010,Stereo headphone terminal<G>

SPEAKER SWITCH PC BOARD

NOTE: <D>: Only 120V model
<G>: Only 220V model
<W>: Only Worldwide model

SCHEMATIC DIAGRAM

TUNER SECTION—
—120V MODEL—

1AAR-3276-4 2/2

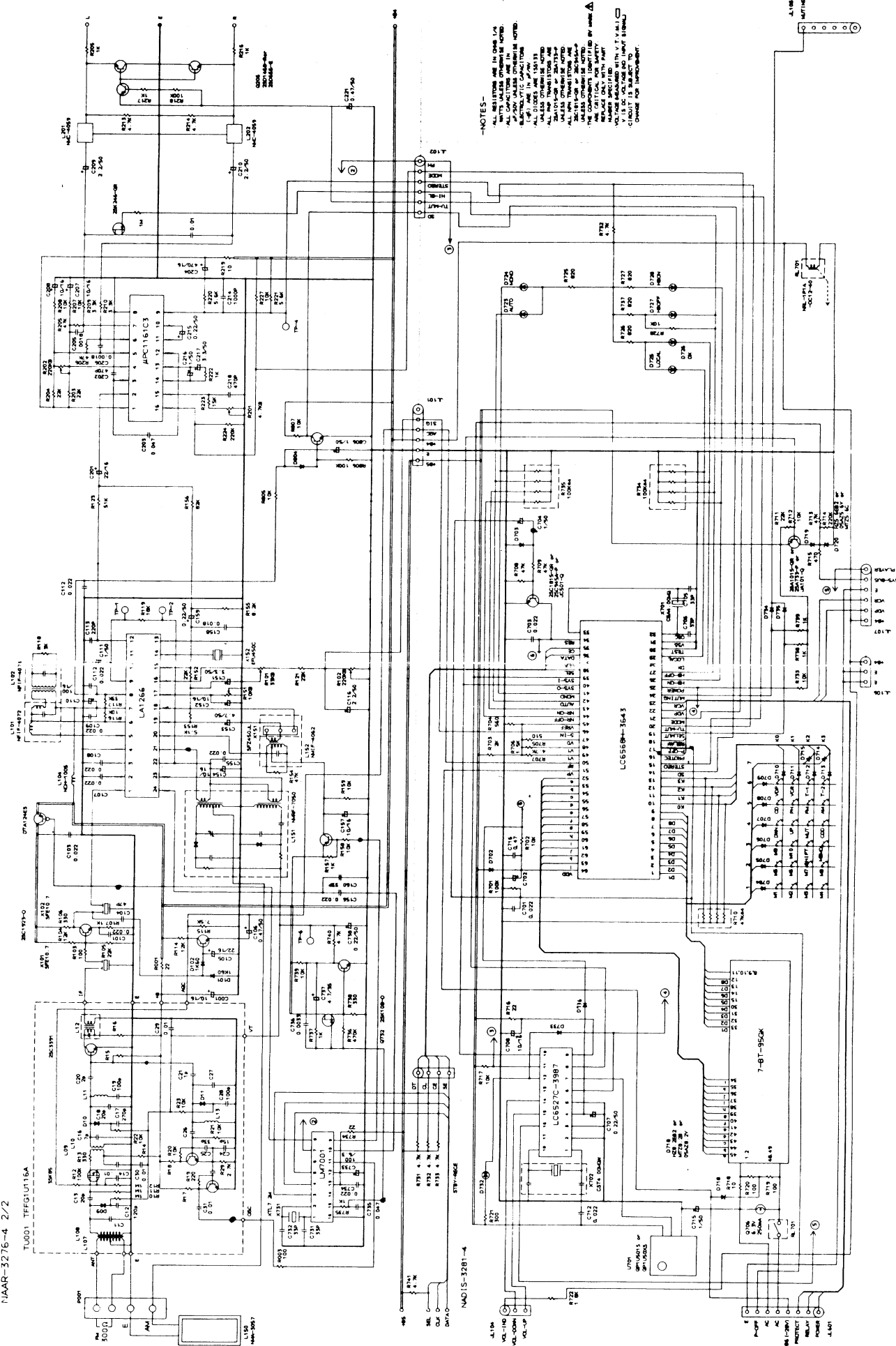

-NOTES-
ALL RESISTORS ARE IN OHMS UNLESS NOTED
ALL CAPACITORS ARE IN MICRO-FARADS UNLESS NOTED
ALL DIODES ARE IN VOLTS UNLESS NOTED
ALL TRANSISTORS ARE UNLESS OTHERWISE NOTED UNLESS OTHERWISE NOTED UNLESS OTHERWISE NOTED UNLESS OTHERWISE NOTED UNLESS OTHERWISE NOTED
THE ORIGINAL FOR SAFETY PART NUMBER SPECIFIED
VOLTAGE REGULATOR WITH TYPICAL R.F.P.M. CIRCUIT IS SUBJECT TO CHANGE FOR IMPROVEMENT

SCHEMATIC DIAGRAM

AMPLIFIER SECTION -
120V MODEL -

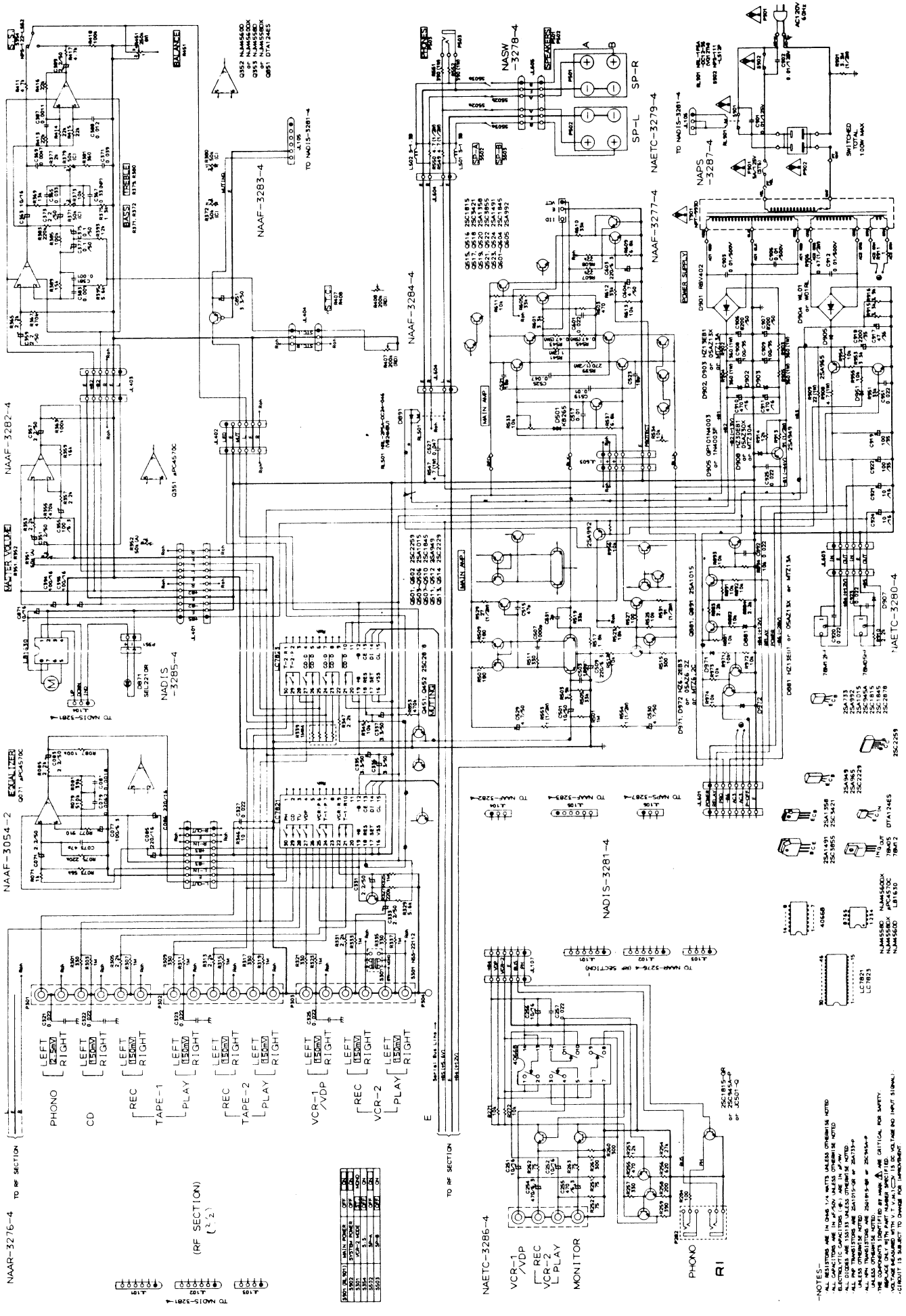

RESISTOR VALUE	CODE	RESISTOR VALUE	CODE
3300	330	10000	10K
330	33	1000	1K
33	3.3	100	100
3.3	330	10	10
330	33	1	1
33	3.3	0.1	0.1
3.3	330	0.01	0.01
330	33	0.001	0.001
33	3.3	0.0001	0.0001
3.3	330	0.00001	0.00001

- NOTES -
- ALL RESISTORS ARE IN OHMS UNLESS OTHERWISE NOTED
 - RESISTOR TOLERANCE IS 1% UNLESS OTHERWISE NOTED
 - ALL CAPACITORS ARE IN MICROFARADS UNLESS OTHERWISE NOTED
 - UNLESS OTHERWISE NOTED, CAPACITORS ARE 50V
 - ALL PARTS IDENTIFIED BY PART NUMBER OR VALUE
 - THE COMPONENTS IDENTIFIED BY PART NUMBER ARE CRITICAL FOR SAFETY.
 - FOR REPAIR, REPLACE WITH AN EQUIVALENT PART OR THE ORIGINAL.
 - CIRCUIT IS SUBJECT TO CHANGE FOR IMPROVEMENT.

PRINTED CIRCUIT BOARD-PARTS LIST

FM/AM TUNER AND SELECTOR CIRCUIT PC BOARD(NAAR
-3276-4/4A/4B)

CIRCUIT NO.	PART NO.	DESCRIPTION	CIRCUIT NO.	PART NO.	DESCRIPTION
	Front end				
TU001	240070	TFFG1U116A <D>	L102	233402	NFIF-4073
	240081	TFFG3E <G/W>	L152	232139	NMIF-4062
	ICs			Coils	
Q104	22240039	LA1266	L103	233383	NMC-6070 <G/W>
Q201	222678	μ PC1161C3	L104	233105	NCH-1005
Q301	22240079	LC7821	L201,L202	233355A	NMC-4059
Q302	22240158	LC7823		RF block	
Q731	22240090	LM7001	L151	232148	NMRF-7050
	Transistors			Ceramic filters	
Q101	2212195	2SK241(GR) <G/W>	X101,X102	3010071	SFE10.7MA5 (RED) <D>
Q102	2211723	2SC1923(O)	X101-X103	3010137	SFE10.7MMK <G/W>
Q103	2211723	2SC1923(O) <G/W>	X151	3010123	SFZ450JL
Q105	2211255 or	2SC1815(GR) or	X152	3010076	BFU450C
	2210746	2SC945A(P)		X'tal	
Q106,Q207	2211455	2SA1015(GR)	X731	3010141	XTL-7.2M
Q107	2212600	DTA124ES		Capacitors	
Q202	2211945	2SK246(GR)	C001	354741009	10 μ F,16V,Elect.
Q205,Q206	2211705 or	2SD655(E) or	C105	354742209	22 μ F,16V,Elect.
	2212794	2SD1468(R)	C106	354784799	0.47 μ F,50V,Elect.
Q303,Q304	2211255 or	2SC1815(GR) or	C110	354741019	100 μ F,16V,Elect.
	2210746	2SC945A(P)	C111	354780109	1 μ F,50V,Elect.
Q451,Q452	2212285 or	2SC2878(A) or	C116	354780229	2.2 μ F,50V,Elect.
	2212286	2SC2878(B)	C151	354780339	3.3 μ F,50V,Elect.
Q501,Q502	2211371 or	2SC2259(O-001) or	C152	354741009	10 μ F,16V,Elect.
	2211372	2SC2259(O-002)	C153	354780479	4.7 μ F,50V,Elect.
Q503-Q506	2211455	2SA1015(GR)	C154,C157	354741009	10 μ F,16V,Elect.
Q507-Q510	2211732 or	2SC1845(F) or	C159	354782299	0.22 μ F,50V,Elect.
	2211733	2SC1845(E)	C201	354742209	22 μ F,16V,Elect.
Q511,Q512	2211353 or	2SA949(O) or	C204	354744719	470 μ F,16V,Elect.
	2211354	2SA949(Y)	C207,C208	354741009	10 μ F,16V,Elect.
Q513,Q514	2211633 or	2SC2229(O) or	C209,C210	354780229	2.2 μ F,50V,Elect.
	2211634	2SC2229(Y)	C215	354782299	0.22 μ F,50V,Elect.
Q732	2212294	2SK108(D)	C216	354780109	1 μ F,50V,Elect.
Q733	2211255 or	2SC1815(GR) or	C217	354780339	3.3 μ F,50V,Elect.
Q802,Q892	2210746	2SC945A(P)	C218	370134714	470pF \pm 5%,100V,APS
Q881,Q891	2211455	2SA1015(GR)	C221	354784799	0.47 μ F,50V,Elect.
Q903	2211353 or	2SA949(O) or	C331-C334	354780229	2.2 μ F,50V,Elect.
	2211354	2SA949(Y)	C335-C337	354780339	3.3 μ F,50V,Elect.
Q951,Q971	2211255 or	2SC1815(GR) or	C501,C502	354781009	10 μ F,50V,Elect.
Q972	2210746	2SC945A(P)	C509,C510	354722219	220 μ F, 6.3V,Elect.
Q952	2211643 or	2SA965(O) or	C529,C530	354780479	4.7 μ F,50V,Elect.
	2211644	2SA965(Y)	C733	354721019	100 μ F, 6.3V,Elect.
Q953	2211792 or	2SA992(F) or	C737	354780479	4.7 μ F,50V,Elect.
	2211793	2SA992(E)	C738	354782299	0.22 μ F,50V,Elect.
	Diodes		C806	354780109	1 μ F,50V,Elect.
D101,D102	223132	1K60	C903,C905	335251039	0.01 μ F,500V,Ceramic
D804	223163	1SS133	C906,C907	3504225	8200 μ F,50V,Elect.
D881,D902	224151301,	05AZ13X,	C908,C909	354761019	100 μ F,35V,Elect.
D903	224651301 or	HZ13EB1 or	C910,C911	354744719	470 μ F,16V,Elect.
	224451301	MTZ13A	C912	335251039	0.01 μ F,500V,Ceramic
D891	223163	1SS133	C917	354764709	47 μ F,35V,Elect.
D901	22380022	RBV402	C918	354762229	2200 μ F,35V,Elect.
D904	223862 or	WL01 or	C919	354761019	100 μ F,35V,Elect.
	223890	W01RL	C921,C924	354741009	10 μ F,16V,Elect.
D905	223880 or	GP101N4003 or	C922	354761019	100 μ F,35V,Elect.
	223896	1N4003F		Resistors	
D908	224153001,	05AZ30X,	R101	5210067	N06HR33KBD,Semi-fixed
	224453001 or	MTZ30A or	R102	5210072	N06HR220KBD,Semi-fixed
	224653001	HZ30EB1	R151	5210064	N06HR10KBD,Semi-fixed
D951	223163	1SS133	R201	5210062	N06HR4.7KBD,Semi-fixed
D971,D972	224650623,	HZ6.2EB3,	R202	5210072	N06HR220KBD,Semi-fixed
	224450623 or	MTZ6.2C or	R339,R340	49163105404	1Mohm \times 4,1/10W,Network
	224150623	05AZ6.2Z	R529,R530	442522704	27ohm,1/2W,Metal oxide film
	Transformers		R531,R532	442529104	91ohm,1/2W,Metal oxide film
L101	233401	NFIF-4072	R547,R548	441620474	4.7ohm,1W,Metal oxide film
			R553,R554	442520104	1ohm,1/2W,Metal oxide film

POWER AMPLIFIER PC BOARD

CIRCUIT NO.	PART NO.	DESCRIPTION
R902-R905	441623614	360ohm,1W,Metal oxide film
R906	442524794	0.47ohm, 1/2W,Metal oxide film
R908	441620474	4.7ohm,1W,Metal oxide film
R909	441622204	22ohm,1W,Metal oxide film
R913	442529104	91ohm, 1/2W,Metal oxide film
Relay		
RL501	25065339	NRL-2P5A-DC24-046
Terminals		
P001	25060085	NTM-4PDMN29,Antenna <D>
	25060087	NTM-2PDMN31,Antenna <G/W>
P301-P303	25045213	NPJ-6PDBL-92
Switch		
S301	25065286	NPS-22112,VCR mode
Sockets		
P101,P102	25050270	NSCT-6P98
P402,P602	25050270	NSCT-6P98
P103	25050268	NSCT-4P96
P401	25050275	NSCT-11P103
P601	25050272	NSCT-8P100
JL406	25050269	NSCT-5P57<G/W>
Radiator		
	27160166	

NOTE: <D>: Only 120V model
 <G>: Only 220V model
 <W>: Only Worldwide model

POWER AMPLIFIER PC BOARD(NAAF-3277-4)

CIRCUIT NO.	PART NO.	DESCRIPTION
Transistors		
Q515,Q516	2211255	2SC1815(GR)
Q517,Q518	2212653 or 2212654	2SC3421(O) or 2SC3421(Y)
Q519,Q520	2212643 or 2212644	2SA1358(O) or 2SA1358(Y)
Q521,Q522 ☆	2201703, 2201704 or 2201706	2SC3855(O), 2SC3855(Y) or 2SC3855(P)
Q523,Q524 ☆	2201693, 2201694 or 2201696	2SA1491(O), 2SA1491(Y) or 2SA1491(P)

CAUTION: Replacement for transistor of mark ☆,if necessary, must be made from the same beta group (HFE) as the original type.

Ex. 2SC3855(O) 2SA1491(O)

Same beta group

Q601-Q604	2211732 or 2211733	2SC1845(F) or 2SC1845(E)
Q605	2211792 or 2211793	2SA992(F) or 2SA992(E)
Diodes		
D501,D502	4000120	KB265
Capacitors		
C603	354722219	220 μ F, 6.3V,Elect.
C604	354780479	4.7 μ F,50V,Elect.
Resistors		
R533,R534	5210064	N06HR10KBD,Semi-fixed
R539,R540	442522714	270ohm,1/2W,Metal oxide film
R541,R542	441720104	1ohm,2W,Metal oxide film
R543-R546	4000080 or 4500022	0.47ohm,5W,Metal plate
Terminals		
	25060118	NTM-1S52,For leg of power transistor

PRINTED CIRCUIT BOARD-PARTS LIST

VIDEO TERMINAL PC BOARD(NAETC-3286-4/4A)

CIRCUIT NO.	PART NO.	DESCRIPTION
Q251	222840661	4066B
Transistors		
Q252	2211455 or 2210803	2SA1015(GR) or 2SA733(P)
Q253-Q256	2211255 or 2210746	2SC1815(GR) or 2SC945A(P)
Q283	2212485, 2211255 or 2210746	JC501(Q), 2SC1815(GR) or 2SC945A(P) <D>
Capacitors		
C251, C252	354741009	10 μ F,16V,Elect.
C254,C255	354724719	470 μ F,6.3V,Elect.
C256	354741009	10 μ F,16V,Elect.
Terminals		
P251	25045216	NPJ-4PDBL94
P282	25045172	HSJ1003-01-020

VOLUME PC BOARD(NAAF-3282-4/NAAF-3574-1)

CIRCUIT NO.	PART NO.	DESCRIPTION
Q351	22240050	μ PC4570C,IC
Q871	222963	LB1630,IC
C351,C352	354780229	2.2 μ F,50V,Elect. capacitors
C355,C356	354721019	100 μ F,6.3V, Elect. capacitors
C357,C358	354780229	2.2 μ F,50V,Elect. capacitors
C394,C395	354741019	100 μ F,16V,Elect. capacitors
C871	354741009	10 μ F,16V,Elect. capacitor
R351,R352	5104234	N16RGM50KA30F,Variable resistor,Volume <D>
R351, R352	5144009C	N16RGL50KA50KB30F, Variable resistor, Volume <G/W>
R431, R432		
P351	2000635A	NSAS-4P591,Socket
JL403	25050270	NSCT-6P98,Socket
JL104	25050267	NSCT-3P95, Socket <G/W>

VOLUME INDICATOR PC BOARD(NADIS-3285-4/NADIS-3575-1)

CIRCUIT NO.	PART NO.	DESCRIPTION
D871	225241 or 225242	SEL2210R-C or SEL2210R-D,LED
	27190545	Holder,LED

CONST. VOLTAGE CIRCUIT PC BOARD(NAETC-3280-4)

CIRCUIT NO.	PART NO.	DESCRIPTION
Q901	222780125	NEC 78M12HF,IC
Q902	222780055	NEC 78M05HF,IC
D907	223163	1SS133,Diode

SWITCH PC BOARD(NAAF-3284-4)

CIRCUIT NO.	PART NO.	DESCRIPTION
R407,R408	6182005	N25LGL200KRD10Z,Variable resistor

EQUALIZER AMPLIFIER PC BOARD(NAAF-3054-2/3)

CIRCUIT NO.	PART NO.	DESCRIPTION
IC		
Q071	22240191 or 222570	NJM4565DD or NJM4560DX
Elect. capacitors		
C071,C072	354780229	2.2 μ F,50V
C077,C078	354721019	100 μ F,6.3V
C083,C084	354780229	2.2 μ F,50V
C085,C086	354742219	220 μ F,16V
Plug		
P071	25055334	NPLG-9P317

POWER SUPPLY CIRCUIT PC BOARD(NAPS-3287-4/4A/4B)

CIRCUIT NO.	PART NO.	DESCRIPTION
C901,C902	3500065A	Δ DE7150FZ103PAC400V/125V, Capacitor IS
R901	431523355	Δ 3.3Mohm,1/2W,Solid resistor <D>
S902	25035550	Δ NPS-111-L512P,Power
RL901	25065269	Δ NRL-1P5A-DC12-36,Relay <D>
	25065248	Δ NRL-1P15A-DC12-29,Relay <G/W>
F901a	250113	Δ SN5051,Fuseholders <D/W>
F901	252050	Δ 5A(ST-6),Primary fuse <D/W>
F902a	25050065	Δ YSH-403T,Fuseholders <G/W>
F902	252075	Δ 2.5A-SE-EAK,Primary fuse <G/W>
F903a	25050065	Δ YSH-403T,Fuseholders <G>
F903	252075	Δ 2.5A-SE-EAK,Fuse for AC outlet <G>
	29360626-1	Δ Label, fuse <D>

NOTE: <D>: Only 120V model
<G>: Only 220V model
<W>: Only Worldwide model

NOTE: THE COMPONENTS IDENTIFIED BY MARK Δ ARE CRITICAL FOR RISK OF FIRE AND ELECTRIC SHOCK. REPLACE ONLY WITH PART NUMBER SPECIFIED.

DISASSEMBLING PROCEDURES

1. Top cover

Remove a screw (3TTS+8BQ(BC)) holding the top cover and the back panel.
Remove the four screws (3TTS+8B(BC)) holding the back panel and the chassis.

2. Front panel

Remove the top cover.
Remove the six screws (3TTP+8P(BC)) holding the front panel and the front basket.

3. Power amplifier pc board

Remove the top cover.
Remove the five screws A.
Cut the binder B.

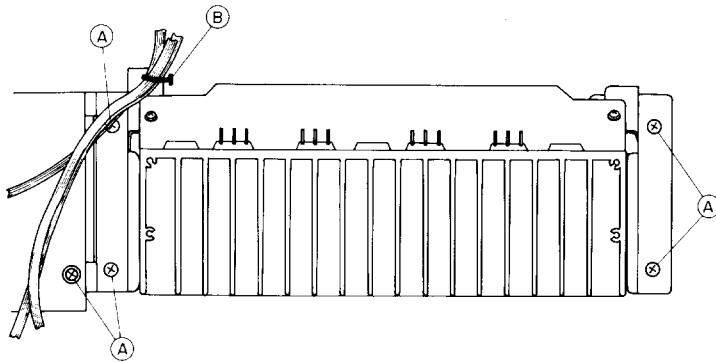

4. FM/AM tuner and selector switch pc board

Remove the top cover.
Remove the three screws C holding the pc board and chassis.
Remove the five screws D holding the back panel and chassis.
Remove the pc board from the two holders.

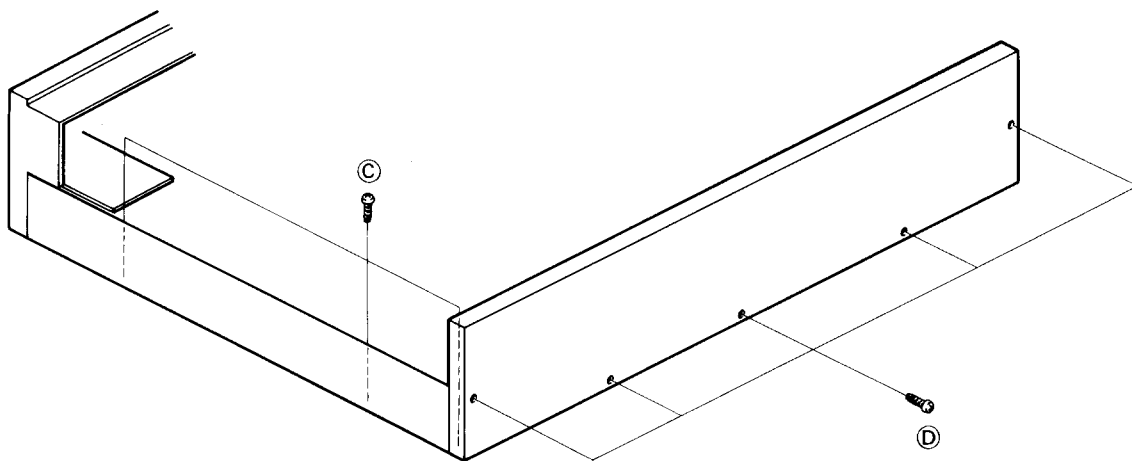

PACKING VIEW

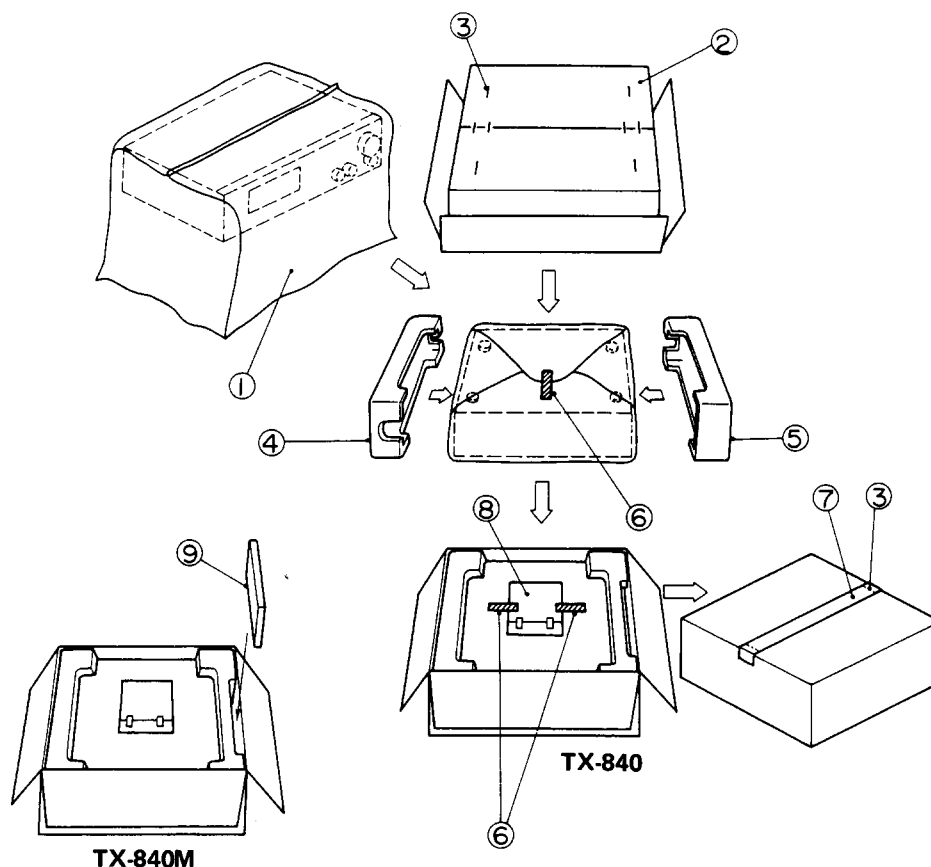

REF. NO.	PART NO.	DESCRIPTION
1	29100034	850×650mm,Poly-vinyl bag
2	29051914	Master carton box (TX-840)
	29051917	Master carton box (TX-840M)
3	282320	Sealing hook
4	29091263A	Pad R
5	29091262A	Pad L
6	261504	Adhesive tape
7	29110046	Damplon tape
8		Accessory bag ass'y
		-120V model-
	29341409	Instruction manual
	292064B	FM antenna
	232140	NMA-3057,AM loop antenna
	2010169	Connection cord for RI
	3010054	UM-3,Two batteries (TX-840)
		UM-3,Four batteries (TX-840M)
	24140151	RC-151S,Remote control transmitter (TX-840)
	29100097	250×350mm,Poly-vinyl bag
	29365019	Warranty card (U.S.A. model)
	29358002G	Service station list (U.S.A. model)
		-220V/240V models-
	29341411	Instruction manual
	292092	FM antenna
	232140	NMA-3057,AM loop antenna
	2010169	Connection cord for RI
	3010124	UM-4,Two batteries
	24140149	RC-149S,Remote control transmitter
	29100097	250×350mm,Poly-vinyl bag
	25060123	FM adaptor (240V model)
		-Worldwide model-
	29341411	Instruction manual
	292092	FM antenna
	232140	NMA-3057,AM loop antenna
	2010169	Connection cord for RI
	3010124	UM-4,Two batteries
	24140149	RC-149S,Remote control transmitter
	29100097	250×350mm,Poly-vinyl bag
	25060123	FM adaptor
	25055018	CV-K-1,Conversion plug
	24140035	RC-AV20,Remote control transmitter (TX-840M)
	29341378	Instruction manual for remote control transmitter (Refer to the service manual of RC-AV20M)

ONKYO CORPORATION

International Division: No. 24 Mori Bldg., 23-5, Nishi-Shimbashi 3-chome, Minato-ku, TOKYO 105. JAPAN Telex: 242-3551 ONKYO J. Tel. 03-432-6981

ONKYO U.S.A. CORPORATION

200 Williams Drive, Ramsey, N.J. 07446 Telex: 25-710-988-1033 Tel. 201-825-7950